

Math 2210 #8

Surfaces in Three-Space

Quick Review of the Conic Sections

a) Parabola $y = x^2$ and $x = y^2$

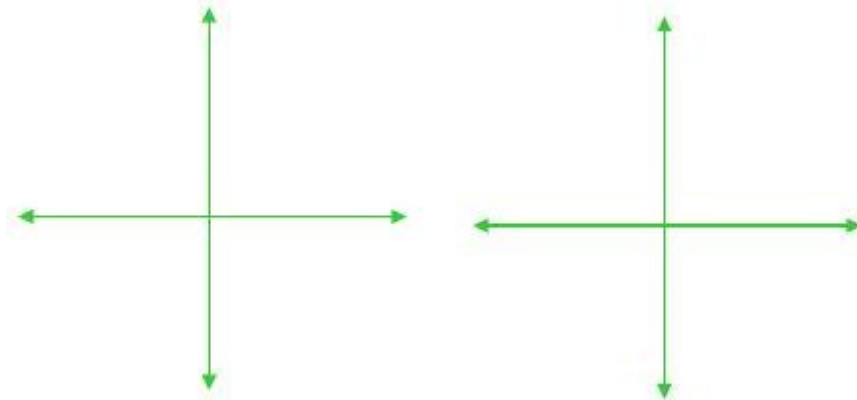

b) Ellipse $\frac{x^2}{a^2} + \frac{y^2}{b^2} = 1$

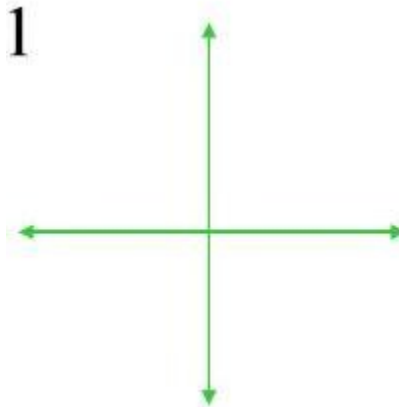

c) Hyperbola $\frac{x^2}{a^2} - \frac{y^2}{b^2} = 1$ and $\frac{y^2}{b^2} - \frac{x^2}{a^2} = 1$

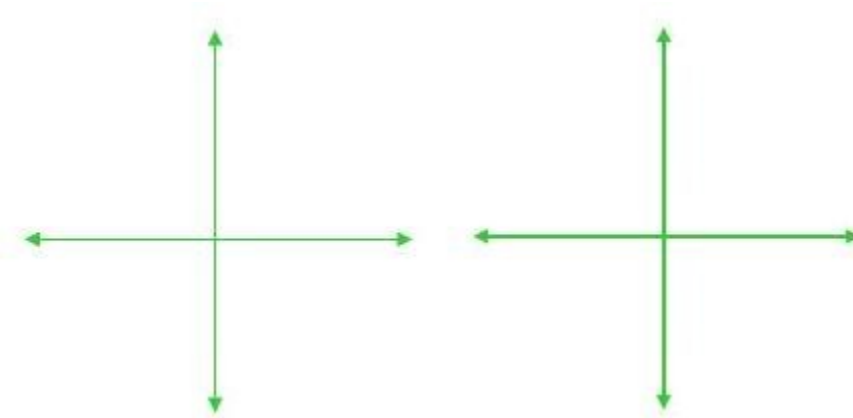

Surfaces in Three-Space

The graph of a 3 -variable equation which can be written in the form $F(x, y, z) = 0$ or sometimes $z = f(x, y)$ (if you can solve for z) is a surface in 3D. One technique for graphing them is to graph cross-sections (intersections of the surface with well-chosen planes) and/or traces (intersections of the surface with the coordinate planes).

We already know of two surfaces:

- a) plane $Ax + By + Cz = D$
- b) sphere $(x - h)^2 + (y - k)^2 + (z - l)^2 = r^2$

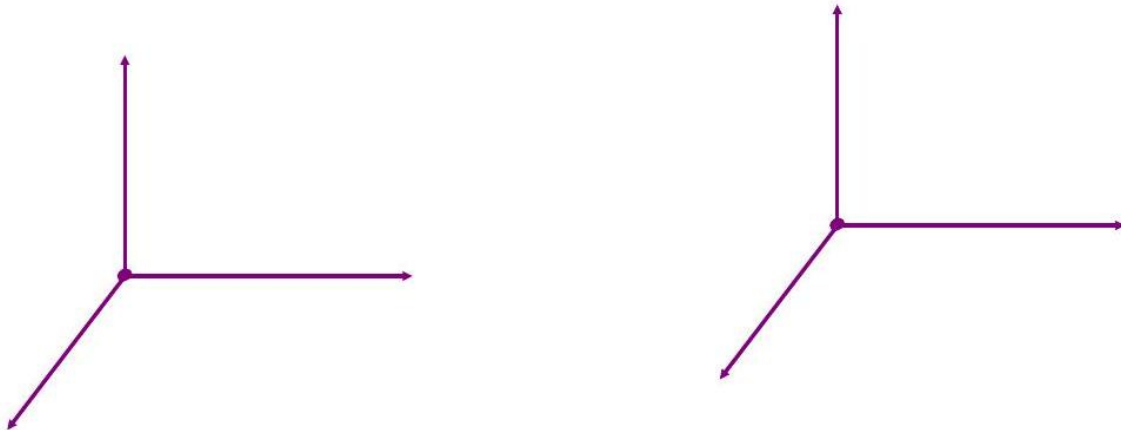

EX 1

Sketch a graph of $z = x^2 + y^2$ and $x = y^2 + z^2$.

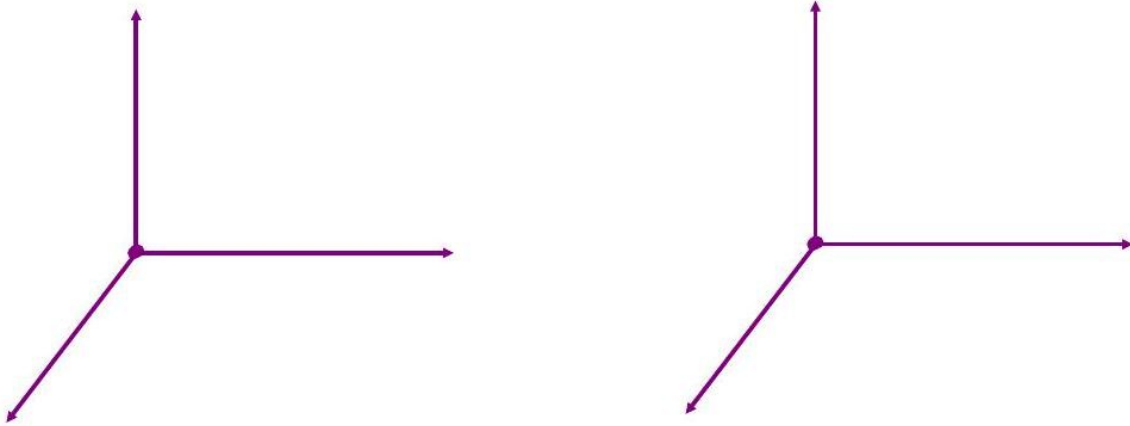

A cylinder is the set of all points on lines parallel to ℓ that intersect C where C is a plane curve and ℓ is a line intersecting C , but not in the plane of C

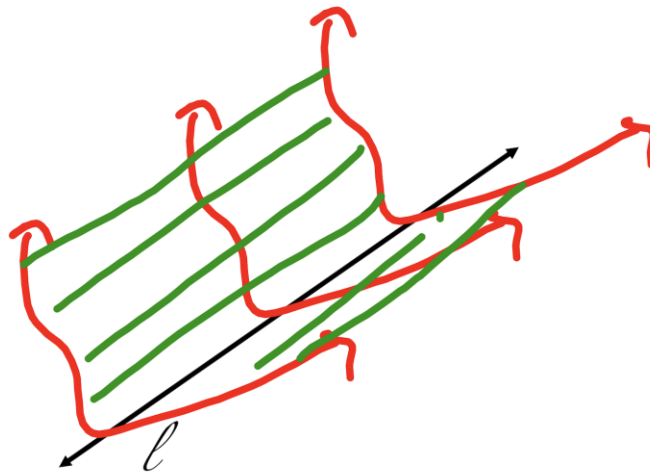

A Quadric Surface is a 3D surface whose equation is of the second degree.

The general equation is

$$Ax^2 + By^2 + Cz^2 + Dxy + Exz + Fyz + Gx + Hy + Iz + J = 0,$$

given that $A^2 + B^2 + C^2 \neq 0$.

With rotation and translation, these possibilities can be reduced to two distinct types.

1. $Ax^2 + By^2 + Cz^2 + J = 0$
2. $Ax^2 + By^2 + Iz = 0$

Basic Quadric Surfaces

ELLIPSOID

$$\frac{x^2}{a^2} + \frac{y^2}{b^2} + \frac{z^2}{c^2} = 1$$

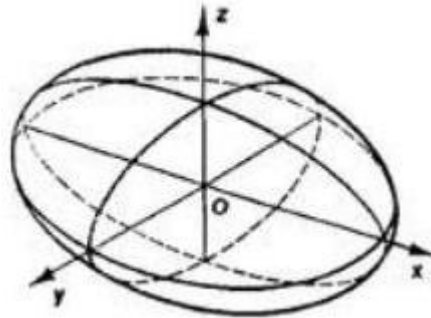

HYPERBOLOID OF ONE SHEET

$$\frac{x^2}{a^2} + \frac{y^2}{b^2} - \frac{z^2}{c^2} = 1$$

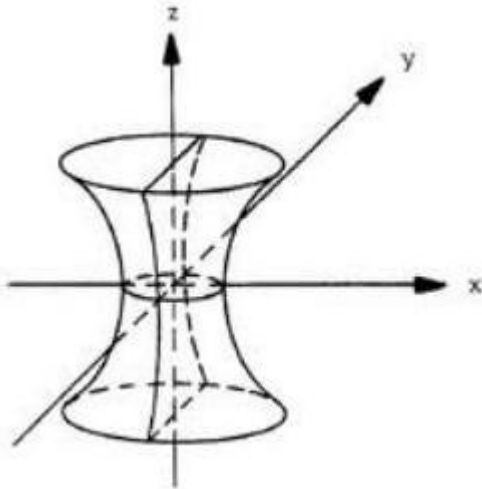

HYPERBOLOID OF TWO SHEETS

$$\frac{x^2}{a^2} - \frac{y^2}{b^2} - \frac{z^2}{c^2} = 1$$

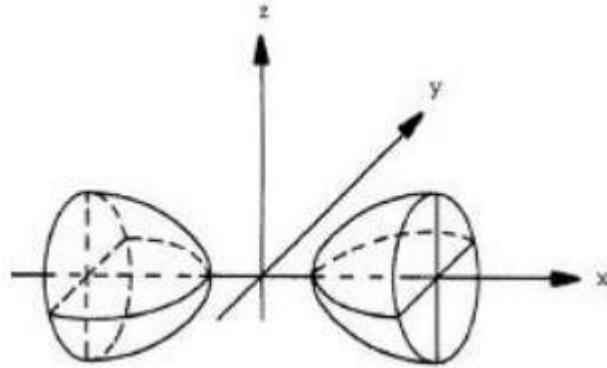

ELLIPTIC PARABOLOID

$$z = \frac{x^2}{a^2} + \frac{y^2}{b^2}$$

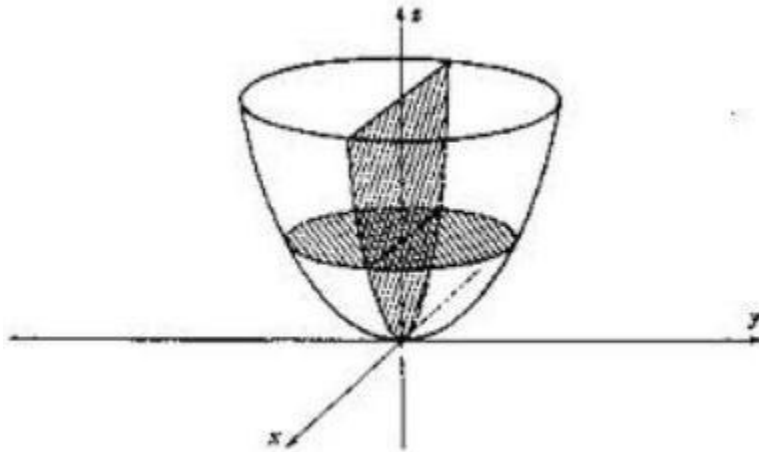

HYPERBOLIC PARABOLOID

$$z = \frac{y^2}{b^2} - \frac{x^2}{a^2}$$

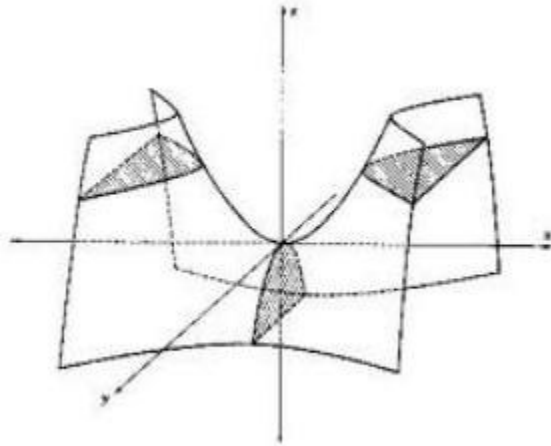

ELLIPTIC CONE

$$\frac{x^2}{a^2} + \frac{y^2}{b^2} - \frac{z^2}{c^2} = 0$$

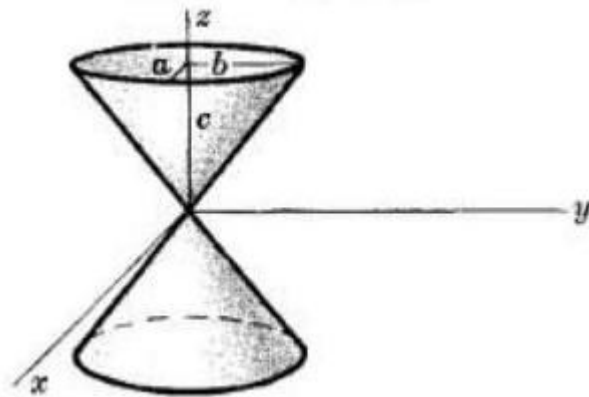

EX 2

Name and sketch these graphs

2a)

$$9x^2 + y^2 - z^2 = -4$$

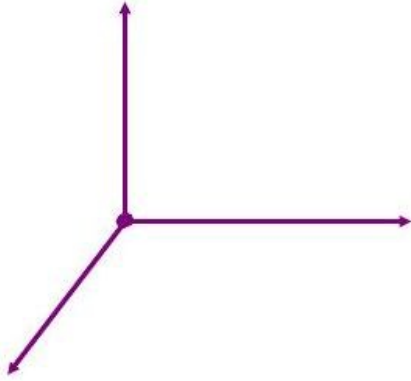

2b)

$$9x^2 + y^2 - z^2 = 4$$

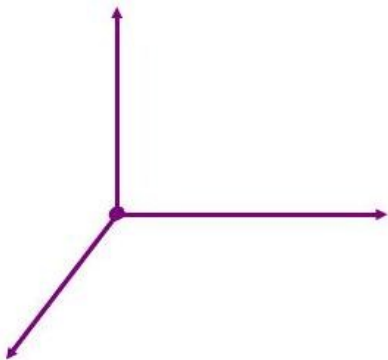

2c)

$$x^2 + 4y^2 - z = 0$$

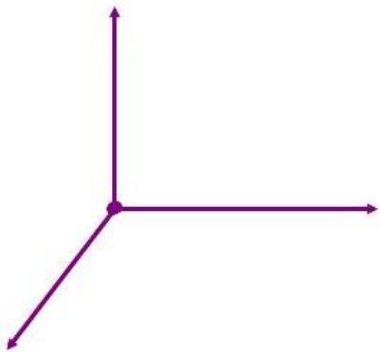

2d)

$$x^2 + y^2 = 1$$

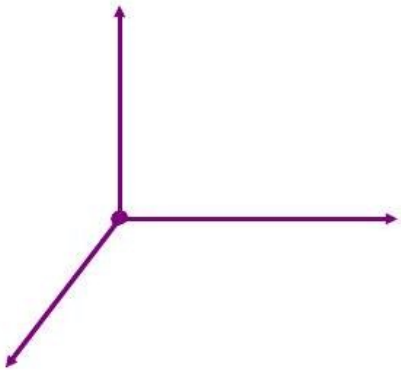

2e)

$$x^2 - y^2 = 25$$

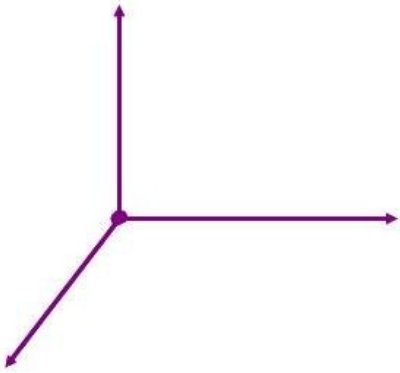

2f)

$$z = y^2$$

