

Math 2210 #19

Double Integrals Over Rectangles, Iterated Integrals

EX 1

$$\text{If } f(x, y) = \begin{cases} -1 & 1 \leq x \leq 4, \quad 0 \leq y < 1 \\ 2 & 1 \leq x \leq 4, \quad 1 \leq y \leq 2 \end{cases}$$

find the signed volume between the $z = f(x, y)$ surface and the xy -plane.

Definition (Double Integral)

Let $z = f(x, y)$ be defined on a closed rectangle, R .

If $\lim_{|p| \rightarrow 0} \sum_{k=1}^n f(\bar{x}_k, \bar{y}_k) \Delta A_k$ exists, then f is integrable over R and the double integral

$$\iint_R f(x, y) dA = \lim_{|p| \rightarrow 0} \sum_{k=1}^n f(\bar{x}_k, \bar{y}_k) \Delta A_k$$

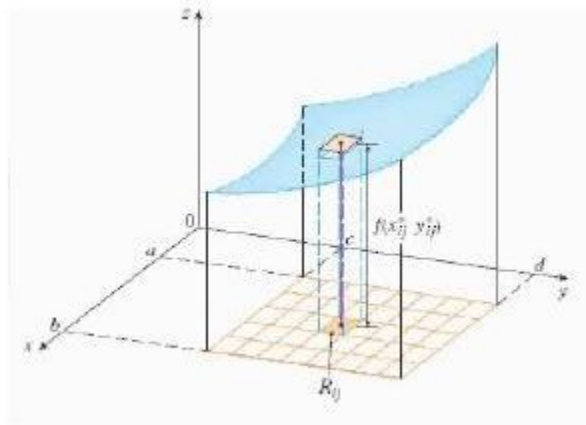

Integrability Theorem

If f is continuous on the closed rectangle R , then f is integrable on R .

EX 2

Let $R = (x, y) \mid 0 \leq x \leq 6, 0 \leq y \leq 4$ and $f(x, y) = 16 - y^2$. Partition R into 6 equal squares by lines $x = 2, x = 4$ and $y = 2$. Approximate $\iint_R f(x, y) dA$ as $\sum_{k=1}^6 f(\bar{x}_k, \bar{y}_k) \Delta A_k$ where (\bar{x}_k, \bar{y}_k) are centers of squares.

Iterated Integrals

The total volume is the sum of many rectangular boxes and then we take the limit as the number of boxes goes to infinity to get the exact volume.

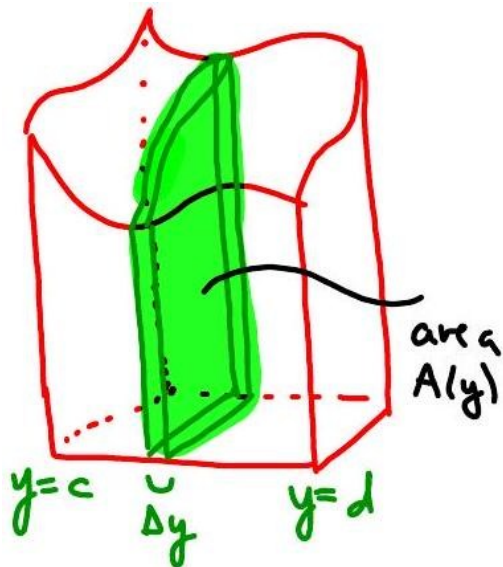
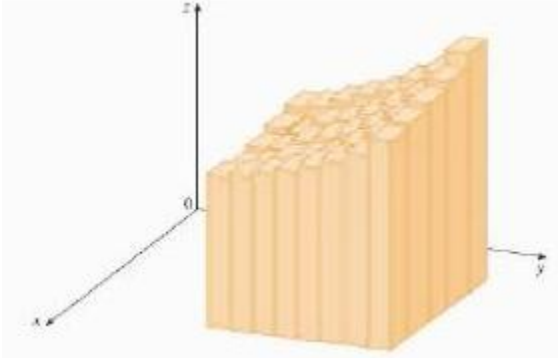

To find this volume, we can take thin "slab" cross-sections and add them up. Each slab has volume $A(y)\Delta y$.

$$V = \int_c^d A(y)dy$$
$$A(y) = \int_a^b f(x,y)dx$$

Properties of the Double Integral

A) It is a linear operator

a. $\iint_R kf(x, y)dA = k \iint_R f(x, y)dA$ and

b. $\iint_R [f(x, y) + g(x, y)] dA = \iint_R f(x, y) dA + \iint_R g(x, y) dA$

B) Additive on rectangles $\iint_R f(x, y)dA = \iint_{R_1} f(x, y)dA + \iint_{R_2} f(x, y)dA$

where R_1 and R_2 overlap only on a line segment and comprise all of R

C) If $f(x, y) \leq g(x, y)$, then $\iint_R f(x, y)dA \leq \iint_R g(x, y)dA$

D) $\iint_R kdA = k \iint_R dA = kA(R)$

EX 3

Calculate $\iint_R f(x, y)dA$ where $f(x, y) = 7 - y$

$$R = (x, y) \mid 0 \leq x \leq 2, 0 \leq y \leq 1$$

Hint: Sketch it and see if you recognize it.

Let's practice computing some double integrals.

EX 4

Evaluate $\int_0^4 \left[\int_{-1}^2 (x^2 - 3y) dx \right] dy$

EX 5

$$\int_0^1 \int_0^1 \frac{y}{(xy + 1)^2} dx dy$$

EX 6

$$\iint_R xy \sqrt{1+x^2} dA = (x,y) \mid 0 \leq x \leq \sqrt{3}, 1 \leq y \leq 2$$

EX 7

Find the volume of the solid in the first octant enclosed by $z = 4 - x^2$ and $y = 2$.