

Math 1210 #20.5

Optimization Problems

EX 1

An open box is made from a 12'' by 18'' rectangular piece of cardboard by cutting equal squares from each corner and turning up the sides. Find the volume of the largest box that can be made in this manner.

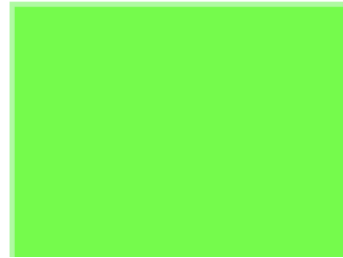

EX 2

A Norman window is constructed by adjoining a semicircle to the top of an ordinary rectangular window. Find the dimensions of the window of maximum area if the total outer perimeter is 18 meters.

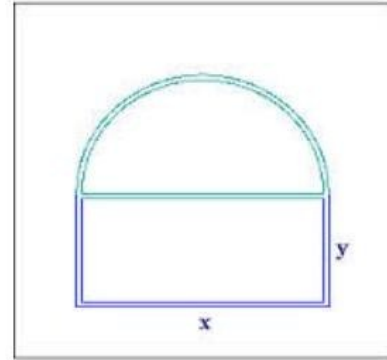

EX 3

The cross-sections of an irrigation canal are isosceles trapezoids with lengths as shown. Determine the angle of elevation of the sides so that the area of the cross sections is maximum.

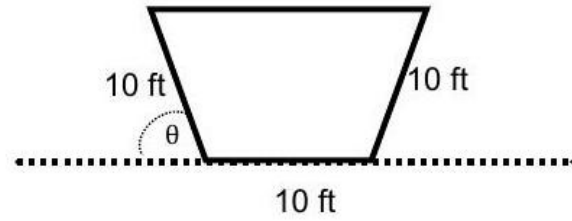

EX 4

Find the volume of the largest right circular cylinder that can be inscribed in a sphere of radius 8 m .

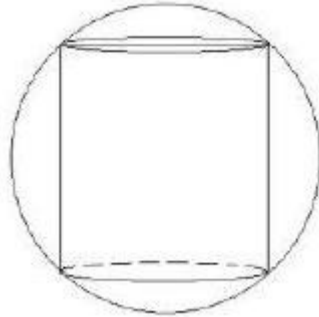

EX 5

A right circular cylinder is to be designed to hold a liter of liquid. Find the dimensions of such a cylinder which uses the least amount of material in its construction.

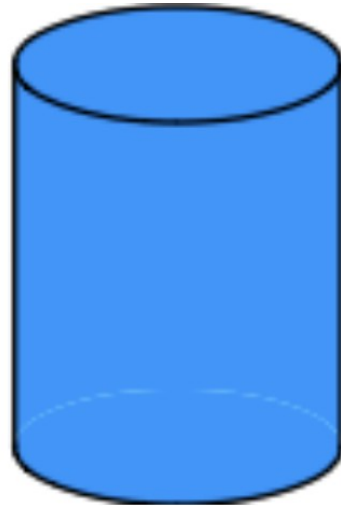

EX 6

Two vertical poles which are 20 m apart are secured by a rope going from the top of the first pole to a point on the ground between the poles and then to the top of the second pole. The second pole is twice as tall as the first pole. Find the position of attachment which requires the least rope.

