

INTRODUCTION TO HYPERBOLIC AND AUTOMATIC GROUPS

S. M. GERSTEN

1.0. **Introduction.** These notes comprise the revised and edited text of two hour lectures I delivered at the CRM Summer School on Groups held at Banff in August 1996. I made no attempt at completeness, but tried to introduce the subject to novices from the attractive drawings of M. Escher, and I made guesses from the list of speakers about what aspects of the subject I should introduce to make my lectures useful to them. Thus I began at the beginning, and to quote G. Baumslag, ended very near the beginning. I have included a short bibliography of source material on the subject along with some of my personal comments scattered in the text about what I have found useful from these references, each of which is good in its own way for an aspect of the subject. The reader should consult these for a more extensive bibliography.¹

1.1. We start with a comparison of two lithographs of M. Escher.

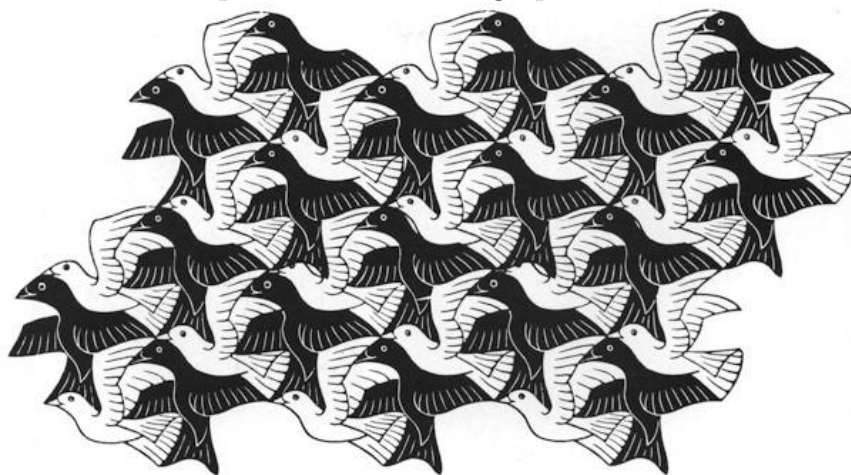

Figure 1. Euclidean Escher picture

Partially supported by NSF grant DMS-9500769

¹Theorems, examples, or exercises are indicated with an asterisk * if the proof is omitted or if the sketch given is not in keeping with the otherwise elementary character of these notes. These theorems so indicated can be looked up in the references, and the starred exercises or examples ignored, if the terms are unfamiliar. I have tried to make this exposition intelligible to a reader who has completed a year's graduate study or has a good undergraduate background in math.



Figure 2. Hyperbolic Escher picture

Figure 1 is part of a tiling of the Euclidean plane, which we imagine as continued in all directions, and Figure 2 is a beautiful tessellation of the Poincaré unit disc model of the hyperbolic plane by white tiles representing angels and black tiles representing devils. An important feature of the second is that all white tiles are mutually congruent as are all black tiles; of course this is not true for the Euclidean metric, but holds for the Poincaré metric $ds^2 = 4\frac{dx^2 + dy^2}{(1 - r^2)^2}$, where $r^2 = x^2 + y^2$.² One feature distinguishing the figures is immediate. There is no natural boundary associated to the Euclidean tiling, whereas the boundary of the disc limits the hyperbolic tiling. This circle is not part of the hyperbolic plane, which in this model consists of points in the interior of the disc, but nevertheless it is apparent from the model.

A second less immediate feature distinguishing them is the so-called isoperimetric inequality. If we imagine circles of radius R drawn from a fixed center, then the number of tiles in the Euclidean drawing in the interior of the circle of radius R for large R is between C_1R^2 and C_2R^2 , where $C_1 < C_2$ are positive constants. In the hyperbolic figure, when we calculate distances and area in the Poincaré metric, we find that the number of black and white tiles in the interior of a circle is bounded by a constant times the area.³

²The irritating factor 4 is present to guarantee that the curvature is -1 .

³There is a silly error in the version of this paper that got into print, where it was stated that the number of tiles in a circle of radius R is proportional to R . The area is exponential in R in the Poincaré metric, and what should have been stated there was the exponential growth in number of tiles with radius, or linear growth in area. I am grateful to Michel Coornaert for pointing this

We say that the Euclidean plane satisfies the quadratic isoperimetric inequality, whereas the hyperbolic plane satisfies the linear isoperimetric inequality. I shall have much more to say about isoperimetric inequalities later.

The third difference I want to point out is more subtle but is crucial for our departure into hyperbolic groups, the property of thin triangles for the hyperbolic plane. For this, and in general for all calculations, it is more convenient to use the conformally equivalent model of the upper half plane \mathbb{H} . This is the set of points (x, y) in the Cartesian plane with $y > 0$ equipped with the Riemannian metric

$$(1.2) \quad ds_{\mathbb{H}}^2 = \frac{ds_{\mathbb{E}}^2}{y^2} = \frac{dx^2 + dy^2}{y^2},$$

where $ds_{\mathbb{E}}$ is the Euclidean metric. We denote the distance between points P, Q in \mathbb{H} by $d_{\mathbb{H}}(P, Q)$ and we recall that this is determined by minimizing the lengths $\int_{\gamma} ds$ of all piecewise smooth paths γ from P to Q in our metric $ds_{\mathbb{H}}$.

Geodesics for this geometry are vertical lines together with arcs of circles orthogonal to the x -axis. Every pair of points in \mathbb{H} is joined by a unique geodesic segment and every geodesic segment can be extended indefinitely in both directions.

A geodesic triangle is one whose sides are segments of geodesics. There are also the so-called ideal geodesic triangles, whose vertices in the disc model lie on the limit circle, and in the model \mathbb{H} lie on the x -axis, where the geodesics are considered as extended arbitrarily far in both directions. One also says that one end point of a vertical geodesic lies “at the point of infinity”. This corresponds to a point on the limit circle in the disc model under the conformal equivalence, but is not visible in \mathbb{H} . An important property is that all ideal triangles are equivalent under the isometry group of \mathbb{H} .⁴

The property we need is the following

Theorem 1.3 (“ δ -thin triangles”). *There is a number $\delta > 0$ so that for all geodesic triangles in \mathbb{H} with vertices, say, A, B , and C , and all points P on side AB , there exists a point Q on at least one of the sides AC or CB so that the distance $d_{\mathbb{H}}(P, Q) \leq \delta$. The optimal value of δ is $\ln(1 + \sqrt{2})$.*

Proof. Let P be on the side AB of the geodesic triangle ABC . First note that by moving the point C toward infinity away from P along the extension of AC , the distance of P to the opposite two sides is only increased. Similarly, we can move the point A to infinity and then move the point B , so we may assume the triangle ABC is ideal. Then using the fact that all ideal triangles are equivalent, we may assume that $A = (0, 0)$, $B = (2, 0)$, and C is the point at infinity, so P is on the circle of radius 1 centered at $(1, 0)$. Symmetry considerations then show that it suffices to prove that $d_{\mathbb{H}}(P, Q) \geq d_{\mathbb{H}}(P_1, Q_1)$ in Figure 3 below, where $P = (1, 1)$; here PQ and P_1Q_1 are segments of geodesics.

out.

⁴This follows from the facts (1) that linear fractional transformations $x \mapsto (ax + b)(cx + d)^{-1}$ act transitively on sets consisting of three distinct points of $\mathbb{R} \cup \{\infty\}$, where a, b, c and d are real numbers and $ad - bc = 1$, and (2) that each such linear fractional transformation acts as an isometry of \mathbb{H} .

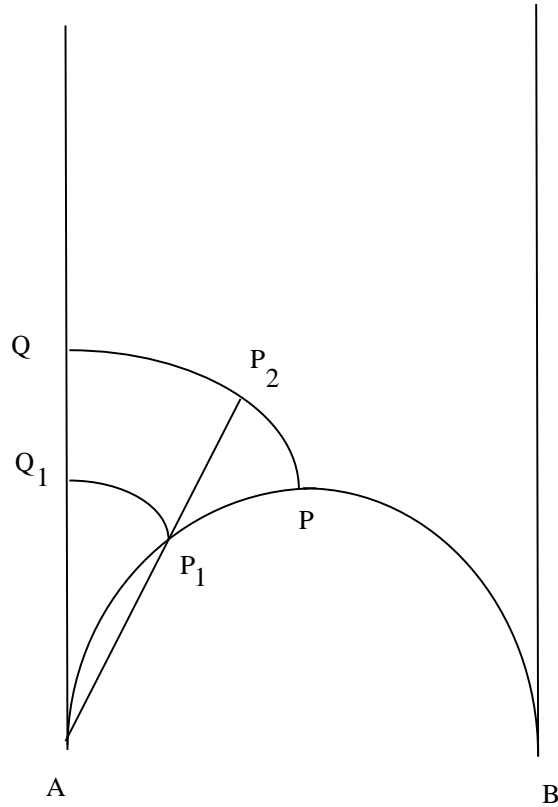

Figure 3. Thin triangles

But by (1.2), the homothety $z \mapsto kz$ induces an isometry of \mathbb{H} , where $k > 0$ and where z is the complex coordinate of a point. Since PQ and P_1Q_1 are on circles centered at $(0, 0)$, there is a unique value of k for which the homothety takes the second arc onto the arc P_2Q , where P_2 is a point of the arc PQ . It follows that $d_{\mathbb{H}}(P_1, Q_1) = d_{\mathbb{H}}(P_2, Q) \leq d_{\mathbb{H}}(P, Q)$.

Thus all geodesic triangles in \mathbb{H} are $\delta = d_{\mathbb{H}}(P, Q)$ -thin. It now becomes a problem of integration to calculate δ .

1.3.1 Exercise. Carry out the calculation. (Hint: Parametrize the arc PQ on the circle of radius $\sqrt{2}$ by $x = \sqrt{2} \cos \theta$, $y = \sqrt{2} \sin \theta$, $\pi/4 \leq \theta \leq \pi/2$, and calculate $\delta = \int_{\pi/4}^{\pi/2} \csc \theta \, d\theta = \ln(1 + \sqrt{2})$.)

2.0. Geodesic metric spaces. A metric space (X, d) is called geodesic if for all pairs of points x, y in X there is an isometric imbedding $f : [0, d(x, y)] \rightarrow X$ taking the end points of the interval to x and y . The image of f is called a geodesic segment connecting these points, or more simply, a geodesic.

2.1. A complete smooth connected Riemannian manifold with its path metric obtained by minimizing lengths $\int_{\gamma} ds$ of all piecewise smooth paths γ between two points is an example of a geodesic metric space. Note that in contrast with the terminology of Riemannian geometry, our geodesics are minimal geodesics, in the sense that their arc length is the distance between the end points. For example the equator of the round unit sphere is a geodesic in the sense of Riemannian geometry, but a segment on it of length at most π is a geodesic segment in the sense we are using.

2.2. A second example of a geodesic metric space is a Cayley graph of a finitely generated group G . Suppose that A is a finite set of generators for G , in the sense that every element of G can be written as a finite product of elements of A and their inverses. We define a graph $\Gamma_{G,A}$ whose vertex set is G and whose edges are all triples (g, a, g') , where $g, g' \in G$, $a \in A$, and $ga = g'$. This edge is considered to originate at the vertex g and terminate at the vertex g' . The group G acts on the left by left translation on vertices and $x(g, a, g') = (xg, a, xg')$ for the action of the group element x on the edge (g, a, g') . That this makes sense is a consequence of the associative law $x(ga) = (xg)a$.

We can realize this graph as a 1-dimensional CW complex where for each abstract edge (g, a, g') we attach a copy of the unit interval with end points 0,1 identified with vertices g, g' respectively. We shall not distinguish between the graph and its geometric realization in this exposition.

The graph $\Gamma_{G,A}$ admits a natural metric, which we now describe. If $g, g' \in G$, we set $d(g, g')$ to be the minimum length of an edge-path connecting these vertices, where each edge of $\Gamma_{G,A}$ has length 1. This is the same as the minimum length of a word w in the elements of A and their inverses such that $gw = g'$ when the product is evaluated in G , and hence it is called the *word metric* on G for generators A . This metric is extended to all pairs of points of the geometric realization by taking the path metric induced by requiring left action of the group to be an isometric action on the edges and requiring each edge to be isometric to the unit interval in \mathbb{R} . Thus each point is at distance at most $\frac{1}{2}$ from a vertex, and the path metric agrees with the metric already defined on pairs of vertices. With this metric the graph $\Gamma_{G,A}$ becomes a geodesic metric space, and the left translations by elements of G become isometries.

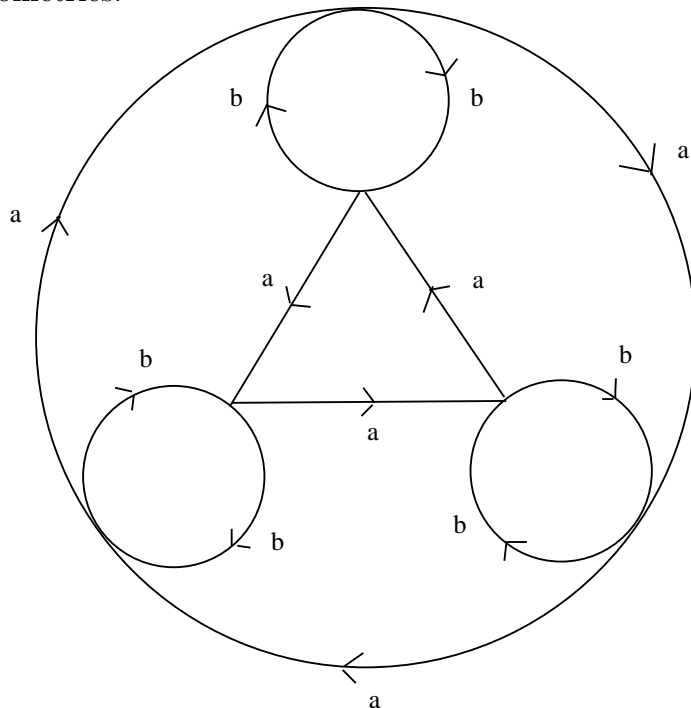

Figure 4. Cayley graph of S_3

Cayley graphs are objects of great beauty. The example above in Figure 4 is a Cayley graph for the symmetric group S_3 and a generating set consisting of a

2-cycle and a 3-cycle.

Another example is the free group F_n with free basis $A = \{x_1, x_2, \dots, x_n\}$. The Cayley graph $\Gamma_{F_n, A}$ is a tree, where each vertex has valence $2n$. The fact that it is a tree is a reflection of the uniqueness of the expression of an element of F_n as a reduced word in the generators and their inverses.

2.3. Exercise. Show conversely that if a Cayley graph $\Gamma_{G, A}$ is a tree, then the group G is free with free basis A .

2.4. Edge-circuits in $\Gamma_{G, A}$ also have significance. Each oriented edge is equipped with a label in $A \cup A^{-1}$. The positive orientation of (g, a, g') has label a whereas if we read the edge with the opposite orientation the label is a^{-1} . The label of an edge-circuit \mathbb{H} is thus a word w in $A \cup A^{-1}$ which multiplies the initial vertex of \mathbb{H} to itself, and hence w evaluates in G to give the identity element of G . Thus labels of edge-circuits give relations among the generators A and their inverses, and furthermore, given a word w in $A \cup A^{-1}$ and a vertex v , there is a unique edge-circuit starting at v with label w . Thus up to choice of initial point, which can be taken to be the identity element of G , there is a 1-1 correspondence between edge-circuits of $\Gamma_{G, A}$ and relations among the generators $A \cup A^{-1}$.

2.5. The Cayley graph and the word metric depend on the choice of generators. A useful strategy in the search for group theoretic invariants is to define a property of a Cayley graph and then elucidate how the property behaves with respect to change of generators. This will be our strategy in defining the notion of hyperbolicity of a group and in defining isoperimetric functions.

3.0. **δ -hyperbolicity.** We say that a geodesic metric space (X, d) is δ -hyperbolic, where $\delta \geq 0$, if for every geodesic triangle ABC and point P on the segment AB there exists a point Q in the union of the sides AC and BC so that $d(P, Q) \leq \delta$.

3.1. Examples.

3.1.1. The hyperbolic plane \mathbb{H} is $\ln(1 + \sqrt{2})$ -hyperbolic.

3.1.2. Every simplicial tree (*i.e.* a 1-dimensional contractible simplicial complex with the path metric, where each edge has length 1) is 0-hyperbolic.

3.1.3. If a geodesic metric space has bounded diameter D , then it is D -hyperbolic.

3.1.4. The Euclidean plane \mathbb{H} is not δ -hyperbolic for any choice of δ . For \mathbb{H} admits a scaling μ_k for each real number $k > 0$ which multiplies all distances by k . Thus if ABC is any nondegenerate triangle and P is on side AB and at distance $d > 0$ from the union of the sides AC and BC , then $\mu_k(P)$ is at distance kd from the sides $\mu_k(A)\mu_k(C) \cup \mu_k(B)\mu_k(C)$ of the triangle $\mu_k(A)\mu_k(B)\mu_k(C)$. Letting $k \rightarrow \infty$ establishes the assertion.

3.2. We define an \mathbb{H} -tree to be a 0-hyperbolic geodesic metric space. Such spaces will be considered in depth in I. Chiswell's lectures in this volume.

3.3. We say a finitely generated group G is hyperbolic⁵ if for some finite set of generators A of G the Cayley graph $\Gamma_{G, A}$ is δ -hyperbolic. According to the strategy proposed at the end of 2.5 to show that hyperbolicity is a group theoretic property we must show that the Cayley graph $\Gamma_{G, A'}$ for any other finite set of generators A'

⁵The terms negatively curved and word hyperbolic and even Gromov hyperbolic have been used to describe the same notion, but we shall say simply hyperbolic.

of G is δ' -hyperbolic for some $\delta' \geq 0$. This will be deduced as a consequence of properties of quasi-geodesics, which we take up next.

3.4. Definition. A (λ, ϵ) quasi-isometric mapping $f : (X, d) \rightarrow (X', d')$ between two metric spaces (X, d) , (X', d') is a (discontinuous) function f satisfying the inequalities

$$\frac{1}{\lambda}d'(f(x), f(y)) - \epsilon \leq d(x, y) \leq \lambda d'(f(x), f(y)) + \epsilon$$

for all $x, y \in X$; here $\lambda > 0$ and $\epsilon \geq 0$. Note that a $(\lambda, 0)$ quasi-isometric mapping is just a bilipschitz mapping with lipschitz constant $\lambda > 0$ and is *a fortiori* continuous. It is the possibility that $\epsilon > 0$ in this notion that allows for discontinuity of the map f . One can think of a quasi-isometric mapping as the view a farsighted person with astigmatism has of the world. The curvature of the lens of the eye accounts for the multiplicative distortion factor λ in distances while the additive constant ϵ has the interpretation that distances closer than ϵ are not resolved clearly.

3.5. A (λ, ϵ) quasi-geodesic mapping of an interval $[a, b] \subset \mathbb{R}$ into (X, d) is called a (λ, ϵ) quasi-geodesic. If we let $a = 0$, $b = +\infty$, then it is called a quasi-geodesic ray. Often one considers a family of (λ, ϵ) quasi-geodesics simultaneously; one calls members of this family quasi-geodesics if the constants λ, ϵ are understood and are the same for all members of the family.

3.6. Two metric spaces (X, d) and (X', d') are quasi-isometric if there are numbers $\lambda > 0$, $\epsilon \geq 0$, and $C \geq 0$, and (λ, ϵ) quasi-isometric mappings $f : (X, d) \rightarrow (X', d')$ and $f' : (X', d') \rightarrow (X, d)$ so that both compositions $f \circ f'$ and $f' \circ f$ are within C of the appropriate identity map. Thus $d(f'(f(x)), x) \leq C$ for all $x \in X$, and similarly for the other composition.

3.7. Example. Let A, A' be two finite sets of generators for the same group G and consider the word metrics d, d' on G for these sets of generators. Now each element $a \in A$ can be written as a word in the generators A' and their inverses, and similarly each $a' \in A'$ can be written as a word in the generators A and their inverses. Let M be the maximum lengths of these words that arise in rewriting the members of each of the two generating sets in terms of the other generators. Then it is easy to see that the identity map $G \rightarrow G$ is an $(M, 0)$ quasi-isometry. If we recall that G is the vertex set for each of the two Cayley graphs $\Gamma_{G,A}, \Gamma_{G,A'}$ and that every point of a Cayley graph is at distance at most $\frac{1}{2}$ from a vertex, we see that the identity map of G extends to quasi-isometric maps $f : \Gamma_{G,A} \rightarrow \Gamma_{G,A'}$ and $f' : \Gamma_{G,A'} \rightarrow \Gamma_{G,A}$ whose compositions both ways are within finite distance of the appropriate identity maps.

3.7.1. Exercise. Verify that the numbers $\lambda = M$, $\epsilon = M + 1$, and $C = (M^2 + 1)/2$ work for the maps f, f' just defined.

Observe that the finiteness of the generating sets A, A' was used in the definition of the number M . This is the only place so far where finite generation was used.

It follows from this discussion that

Proposition 3.8. *Any two Cayley graphs for the same finitely generated group are quasi-isometric geodesic metric spaces.*

3.9. Definition. If A and B are two subsets of the metric space (X, d) , we say that A and B are at finite Hausdorff distance if there is a constant $H > 0$ so that for

every $a \in A$ there is a point $b \in B$ with $d(a, b) \leq H$ and for every $b \in B$ there is a point $a \in A$ with $d(a, b) \leq H$. Thus B is contained in the H -neighborhood of the set A and A is contained in the H -neighborhood of B .

The basic result connecting quasi-isometry and hyperbolicity is the following.

Theorem 3.10* (Quasi-geodesics are close to geodesics). *Let X be a δ -hyperbolic geodesic metric space. Then there is a function $H(\lambda, \epsilon) > 0$ so that for any two points $x, y \in X$, any (λ, ϵ) quasi-geodesic $f : [a, b] \rightarrow X$ with end points mapped to x, y , and any geodesic segment γ with the same end points x, y one has the image of f and the image of γ are at finite Hausdorff distance at most $H(\lambda, \epsilon)$ from each other.*

The result is nontrivial. I find the proof given in the Berkeley notes [Bkly], which is based on exponential divergence of geodesics in a hyperbolic metric space, very accessible. An easier argument for the special case of a complete Riemannian manifold with negative sectional curvatures bounded above by $-\kappa < 0$ appears in [Wordproc]. My understanding is that the result was first observed for the hyperbolic plane by Marston Morse in the 20's, although the terminology of quasi-geodesics was only used by G. Mostow and others after the 60's.

3.10.1. Example. The following example shows one way in which the conclusion of Theorem 3.10 can fail in a nonhyperbolic group. Consider the group $G = \mathbb{Z}^2$ with generating set $A = \{a = (1, 0), b = (0, 1)\}$. If n is a positive number, then it is easy to verify that all geodesics in $\Gamma_{G,A}$ from $(0, 0)$ to (n, n) are of the form words in a and b which involve exactly n a 's and exactly n b 's (and no a^{-1} nor b^{-1}). Two extreme geodesics are given by $a^n b^n$ and $b^n a^n$. The distance between the vertex $(n, 0)$ on the first and $(0, n)$ on the second is $2n$, which can be arbitrarily large. Thus geodesics segments with the same end points can be at arbitrarily large Hausdorff distance in this example.

If we anticipate section 8 on regular languages below, the set of all geodesic words in this example is given by the regular expression $L = \{a, b\}^* + \{A, b\}^* + \{A, B\}^* + \{a, B\}^*$, where $A = a^{-1} = (-1, 0)$ and $B = b^{-1} = (0, -1)$. Thus the set of all geodesic words in this example is a regular language, but the group is not hyperbolic.

3.10.2. Remark. An interesting converse to Theorem 3.10 was discovered by P. Papasoglu [Papa] in the special case of Cayley graphs. He showed that if G is a finitely generated group with finite set A of generators and if there is a number $H \geq 0$ so that all pairs of geodesic segments in $\Gamma_{G,A}$ with the same endpoints are at Hausdorff distance at most H , then G is hyperbolic.

Theorem 3.10 will now be applied to show that the property of a finitely generated group being hyperbolic is independent of the particular finite set of generators.

Theorem 3.11 (quasi-isometry invariance of hyperbolicity). *Let (X, d) and (X', d') be quasi-isometric geodesic metric spaces. If (X, d) is δ -hyperbolic, then there exists $\delta' \geq 0$ so that (X', d') is δ' -hyperbolic.*

Proof. Suppose $f : X \rightarrow X'$ and $f' : X' \rightarrow X$ are both (λ, ϵ) quasi-isometric maps whose compositions both ways are within $C \geq 0$ of the appropriate identity map, and we assume that (X, d) is δ -hyperbolic. Let Δ' be a geodesic triangle in X' . Then $f'(\Delta')$ is a quasi-geodesic triangle in X whose sides are (λ, ϵ) quasi-geodesics.

It follows from Theorem 3.10 that there is a geodesic triangle Δ in X with the same vertices whose sides are each within Hausdorff distance $H = H(\lambda, \epsilon)$ of the corresponding sides of $f'(\Delta')$. It follows that $f'(\Delta')$ is $(2H + \delta)$ -thin, where we can talk about thinness of quasi-geodesic triangles in an obvious sense. Now apply f to get the quasi-geodesic triangle $f(f'(\Delta'))$ in X , which one sees is $(\lambda(2H + \delta) + \epsilon)$ -thin from the way quasi-isometric maps distort distances. But points on the sides of the triangle $f(f'(\Delta'))$ are at distance at most C from the corresponding points on the original triangle Δ . It follows that Δ is $\delta' = (2C + \lambda(2H + \delta) + \epsilon)$ -thin. Thus all geodesic triangles of X' are δ' -thin for this value of δ' , and the result is proved.

3.12. It follows from Theorem 3.11 that *if the Cayley graph $\Gamma_{G,A}$ is δ -hyperbolic, then there exists $\delta' \geq 0$ so that the Cayley graph $\Gamma_{G,A'}$ is δ' -hyperbolic*; here G is a finitely generated group and A and A' are finite sets of generators for G .

It follows that hyperbolicity is a property of groups. In particular although it is defined using one finite system of generators, the property carries over to any other finite system of generators (for a different value of δ).

At the moment, we know from examples and exercises that finite groups and finitely generated free groups are hyperbolic. We now prepare to state a result which provides many more examples of hyperbolic groups.

3.13. Definition. An action of the group G on the topological space X is a mapping $G \times X \rightarrow X$, denoted $(g, x) \mapsto gx$, so that X is a G -set (recall that this means that $1x = x$ for all $x \in X$ and $g'(gx) = (g'g)x$ for all $g, g' \in G, x \in X$) and so that for each $g \in G$ the map $x \mapsto gx$ is a homeomorphism of X onto itself. We are considering G here to have the discrete topology.

The action is called *properly discontinuous* if for each compact subset K of X the collection of groups elements $\{g \in G \mid gK \cap K \neq \emptyset\}$ is finite. A special case of a properly discontinuous action where all point stabilizers in G are trivial (so $gx = x$ for $g \in G, x \in X$, implies $g = 1$) is called a *free action*.

The action is called *cocompact* if the orbit space $G \backslash X$ is compact.

The metric space (X, d) is called *proper* if all balls of finite radius are precompact, in the sense that their closures are compact. In this case X is locally compact.

In many of the examples we shall consider, X will be a metric space and the action will often be by isometries, so that the homeomorphisms of X given by left translation $x \mapsto gx, g \in G, x \in X$, are isometries of X . We say such actions are *isometric*.

3.14. Exercises.

3.14.1. If $\pi : Y \rightarrow X$ is a regular covering map with covering group G , then the action of G on Y by deck transformations is a free action. If X is compact, then the action is cocompact.

3.14.2. The left action of the finitely generated group on its Cayley graph $\Gamma_{G,A}$ is free and cocompact and group elements act by isometries. In addition $\Gamma_{G,A}$ is a proper metric space.

3.14.3. Let M be a closed (and hence compact) connected Riemannian manifold and let \widetilde{M} be its universal cover equipped with the pull-back Riemannian metric from the covering projection $\pi : \widetilde{M} \rightarrow M$. If G is the fundamental group of M , then the action of G on \widetilde{M} by deck transformations is free, isometric, and cocompact, and \widetilde{M} is a proper geodesic metric space.

Theorem 3.15*. *Suppose that the group G acts properly discontinuously and cocompactly by isometries on the proper geodesic metric space (X, d) . Then G is finitely generated, and G with any word metric and (X, d) are quasi-isometric metric spaces.*

A very readable account of this result is given in M. Troyanov's article in the Swiss notes [Swiss]. The result has some important corollaries, which we state as exercises.

3.16. Exercises.

3.16.1. Any Cayley graph $\Gamma_{G,A}$ of the finitely generated group G for finite set A of generators is quasi-isometric to G with the word metric. In fact we already observed this by direct calculation in 3.7.1.

3.16.2. If H is a subgroup of finite index of the group G , then H is finitely generated iff G is finitely generated, and in this case H and G are quasi-isometric for their word metrics. (Hint. The first assertion can be established by covering space theory. As for the second, the action of H on $\Gamma_{G,A}$ obtained by restricting the left action of G to H satisfies the hypotheses of Theorem 3.15.)

3.16.3. Let N be a *finite* normal subgroup of the finitely generated group G . Then the groups G and G/N are quasi-isometric for their word metrics. (Hint. Consider the action of G on any Cayley graph of G/N by left translation by its associated coset modulo N .)

3.16.4. If M is a closed connected Riemannian manifold and \widetilde{M} is the universal cover of M with the pull-back Riemannian metric, then \widetilde{M} is quasi-isometric to the fundamental group of M . This result is due to Švarc and independently to Milnor (who did not use the language of quasi-isometry to state it). They used it to relate the growth of finitely generated groups to the growth of volumes of balls in the universal cover.

3.17. We can now give the promised examples of hyperbolic groups. Note first that hyperbolic n -space \mathbb{H}^n is defined as $\{(x_1, x_2, \dots, x_n) \in \mathbb{H}^n \mid x_n > 0\}$ with the Riemannian metric

$$ds_{\mathbb{H}^n}^2 = \frac{ds_{\mathbb{E}^n}^2}{x_n^2} = \frac{x_1^2 + x_2^2 + \dots + x_n^2}{x_n^2},$$

where $ds_{\mathbb{E}^n}$ is the Euclidean metric. It has the property that every geodesic triangle is contained in a totally geodesic isometric copy of the hyperbolic plane, so \mathbb{H}^n is δ -hyperbolic for $\delta = \ln(1 + \sqrt{2})$. A (closed) hyperbolic n -manifold can be defined as the quotient of \mathbb{H}^n by a cocompact properly discontinuous subgroup of isometries acting freely on \mathbb{H}^n .⁶

3.17.1. If G is a subgroup of the group of isometries of \mathbb{H}^n which acts properly discontinuously and cocompactly on \mathbb{H}^n , then G is (finitely generated and) hyperbolic. This is immediate from Theorem 3.15 and remarks above.

It follows that the symmetry group of the Escher diagram in Figure 2 is a hyperbolic group.

3.17.2.* If G is the fundamental group of a closed Riemannian manifold M all of whose sectional curvatures are strictly negative, then G is hyperbolic. This is an

⁶This is equivalent to the usual definition in Riemannian geometry of a hyperbolic manifold as a closed Riemannian manifold which admits a metric with constant sectional curvatures -1 .

application of the comparison theorems of differential geometry. There is an upper bound $-k$, for some $k > 0$, on the sectional curvatures of \widetilde{M} , by the compactness of M . Then the comparison theorem of Toponogov says that geodesic triangles in \widetilde{M} are at least as thin as those in the plane with metric of constant curvature $-k$. However in this latter space triangles are scaled copies of triangles in \mathbb{H} and hence are uniformly thin.

3.17.3. If H is a subgroup of finite index of the finitely generated group G , then H is hyperbolic iff G is hyperbolic.

3.17.4. Virtually finitely generated free groups are hyperbolic. Here, if \mathcal{P} is a property of groups (so \mathcal{P} is a proper class of groups closed under isomorphism), then a group is called virtually \mathcal{P} if it has a subgroup of finite index which is in \mathcal{P} .

It is amusing to note that finite groups can be characterized as virtually trivial groups.

3.17.5.* Fundamental groups of closed orientable surfaces of genus at least 2 or closed nonorientable surfaces of (nonorientable) genus at least 3 are hyperbolic.⁷ This follows from the uniformization theorem, which in this context states that these surfaces admit hyperbolic structures. A more combinatorial proof of this result will be given in §6.

3.17.6. Triangle groups.* Let $2 \leq m \leq n \leq p$ be integers such that $1/m+1/n+1/p < 1$. Then one shows there exists a geodesic triangle Δ in \mathbb{H} with angles $\pi/m, \pi/n$, and π/p . Consider the pattern generated by reflecting the triangle in its sides, and the resulting figure in all its sides, and so on. It follows from a nontrivial theorem of Poincaré's that the resulting pattern tessellates \mathbb{H} by congruent copies of Δ with disjoint interiors. A readable account of this result is given in [Beard]. The full isometry group of this tessellation is a properly discontinuous cocompact subgroup of isometries of \mathbb{H} . It is generated by reflections in the sides of the original triangle Δ and is called the triangle group $\Delta(m, n, p)$. It is hyperbolic by Theorem 3.15.

There are other important examples of hyperbolic groups, including the CAT(-1)-groups and uniform lattices in rank 1 Lie groups, which time considerations did not permit me to discuss. I shall discuss the important examples of small cancellation groups in §6 below.

4.0. The boundary of a hyperbolic group. This notion never came up in the other lectures at the conference, so I shall be brief.

4.1. Let $\Gamma_{G,A}$ be the Cayley graph for the finitely generated group G with finite set A of generators. Assume that $\Gamma_{G,A}$ is δ -hyperbolic. If R and R' are geodesic rays (*i.e.* (1, 0) quasi-geodesic rays, see 3.5), then we write $R \sim R'$ if they are in a Hausdorff neighborhood of each other. This is clearly an equivalence relation and the boundary ∂G of G is the set of equivalence classes of geodesic rays under this equivalence relation.

4.1.1. Every quasi-geodesic ray is in a Hausdorff neighborhood of a geodesic ray.

Hence ∂G could have been defined in an equivalent manner as the set of equivalence classes of quasi-geodesic rays, where two quasi-geodesic rays are equivalent if they are in Hausdorff neighborhoods of each other.

⁷An orientable surface has genus g if it is the connected sum of n tori and a nonorientable surface has genus g if it is the connected sum of g projective planes.

4.1.2. Consider the disc model for the hyperbolic plane. Show that every geodesic ray determines a unique point on the limit circle and that two rays are equivalent iff they determine the same point.

4.1.3.* Given any point v in $\Gamma_{G,A}$ and geodesic ray R there exists a geodesic ray R' so that $R'(0) = v$ and $R \sim R'$. In fact one considers geodesic segments $vR(t)$ and one shows, using the Ascoli theorem, that these subconverge on compact subintervals of $[0, \infty)$ to a geodesic ray. For full details consult [Stras] Chapter 2.

4.2. There is a natural topology on ∂G for which it is a compact finite dimensional metrizable space [Bndry], called the visual topology. To describe the topology, it is convenient to choose a base point v . Every ray is equivalent to one starting at v , so choose a ray R with $R(0) = v$. If $t, \epsilon > 0$ let $N_\epsilon(R, t)$ be the set of equivalence classes of rays S starting at v such that $d(R(t), S(t)) \leq \epsilon$. These sets are a subbasis for the topology on ∂G . In fact, one only needs to use one value of $\epsilon = 10\delta$ to define this topology [Bndry].

4.2.1. If G and G' are quasi-isometric hyperbolic groups, show that their boundaries ∂G and $\partial G'$ are homeomorphic.

4.2.2. Show that the isometric action of G on $\Gamma_{G,A}$ defines an action on rays preserving the equivalence relation \sim . Show that this induces an action of G on ∂G where each group element acts as a homeomorphism of ∂G .

The boundary is one of the reasons that topologists are so interested in hyperbolic groups. N. Benakli showed in her thesis that the Menger and Sierpiński curves occur naturally as boundaries of hyperbolic groups. The characterization of hyperbolic groups which have the circle as boundary, achieved independently by Gabai, Casson-Jungreis, and Tukia, led to the solution of a classical conjecture of Seifert's, that closed irreducible 3-manifolds containing normal infinite cyclic subgroups in their fundamental groups are Seifert fibred. One of the outstanding problems of 3-dimensional topology is the conjecture that a closed irreducible 3-manifold with an infinite hyperbolic fundamental group admits a Riemannian metric of constant negative curvature. As a result of the work of Bestvina and Mess, it is known that the boundary of such a group is homeomorphic to the 2-sphere.

5.0. Finite presentability of hyperbolic groups.

Let G be a finitely generated group with Cayley graph $\Gamma_{G,A}$ for finite set A of generators and suppose that $\Gamma_{G,A}$ is δ -hyperbolic. Suppose that γ, γ' are geodesics beginning at 1 and ending at g, g' respectively and suppose further that $g' = ga$, where $a \in A$. Then we have a geodesic triangle Δ where one side is of length 1 and the other two sides are γ and γ' . It is convenient to extend the domains of definition of γ, γ' to all nonnegative reals by insisting they be the constant maps after they reach their endpoints. This convention will be followed without further mention.

Lemma 5.1. *We have $d(\gamma(t), \gamma'(t)) \leq 2(\delta + 1)$ for all $t \geq 0$.*

Proof. If P is in the image of γ , then P is at distance at most δ from the union of the other two sides of Δ . If P is unlucky enough to be within δ of the edge-side, then it is at distance at most $\delta + 1$ from the end point of γ' . Thus in any case P is at most $\delta + 1$ from the image of γ' .

Thus we see that for all $0 \leq t \leq d(1, g)$ there exists an $0 \leq s \leq d(1, g')$ so that $d(\gamma(t), \gamma'(s)) \leq \delta + 1$. But γ and γ' are geodesics in this range of values of their

domains, so $|t - s| \leq \delta + 1$ by the triangle inequality. Now using the fact that γ' is geodesic on $[0, d(1, g')]$ we see that $d(\gamma'(t), \gamma'(s)) \leq |t - s| \leq \delta + 1$. Hence by the triangle inequality we have $d(\gamma(t), \gamma'(t)) \leq 2(\delta + 1)$, completing the proof.

5.2. Now we mark off “integer points” $\gamma(i), \gamma'(i)$ on the geodesics $\gamma, \gamma', i \in \mathbb{N}$. We obtain for each i a quadrilateral Q_i , where two sides are geodesics chosen to join $\gamma(i)$ to $\gamma'(i)$ and $\gamma(i + 1)$ to $\gamma'(i + 1)$ and the remaining two sides are edges of $\Gamma_{G,A}$ joining $\gamma(i)$ to $\gamma(i + 1)$ and joining $\gamma'(i)$ to $\gamma'(i + 1)$ (if i lies beyond the range where γ is geodesic, interpret this to be the constant path at the vertex $\gamma(i)$). The boundary label of Q_i is a word in the generators $A \cup A^{-1}$ of length at most $2(2(\delta + 1) + 1) = 4\delta + 6$ which evaluates to 1 in G by the discussion of 2.4. We let \mathcal{R} be the set of all words in $A \cup A^{-1}$ of length at most $4\delta + 6$ which evaluate to 1 in G . Note that \mathcal{R} is a finite set of words.

Theorem 5.3. $\mathcal{P} = \langle A \mid \mathcal{R} \rangle$ is a finite presentation for G .

Proof. Let w be an edge-circuit in $\Gamma_{G,A}$ with $w(0) = 1$. We “cone” w from the base point 1 by geodesics, so, precisely, we choose geodesics γ_j from 1 to $w(j)$. For each i we have the geodesic quadrilateral Q_{ij} with sides joining vertices $\gamma_j(i), \gamma_j(i + 1), \gamma_{j+1}(i + 1), \gamma_{j+1}(i)$ and back to $\gamma_j(i)$. These quadrilaterals fit together to form a disc diagram filling w , as is illustrated in Figure 5 below.

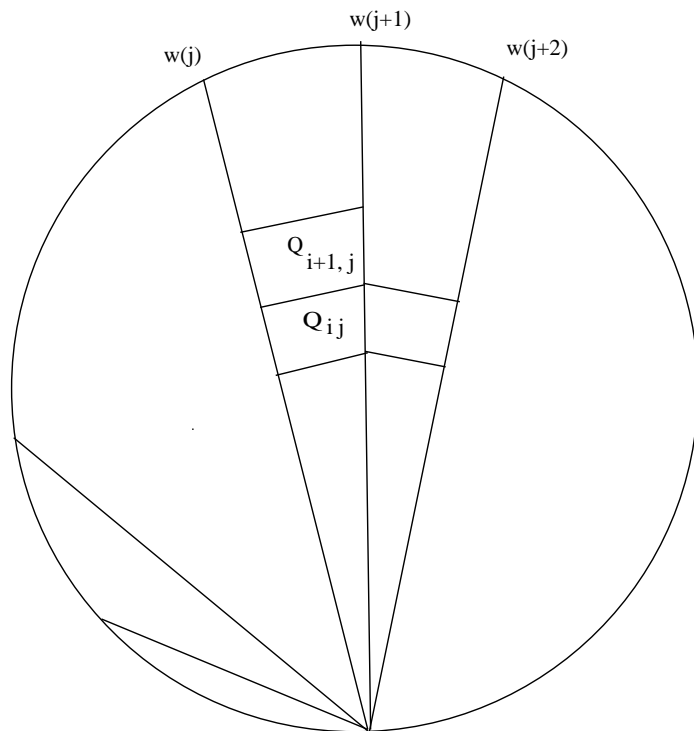

Figure 5. Filling the circuit w

But the label of Q_{ij} is one of the defining relators of \mathcal{P} , and it follows that the label of w , which is a relation among the generators, is a consequence of the relators \mathcal{R} . Thus \mathcal{P} is a finite presentation for G .

5.4. Much more than finite presentability is true for hyperbolic groups. The known finiteness conditions follow from Rips’s theorem*: *if G is a hyperbolic group, then there is a contractible finite dimensional locally finite simplicial complex P and a*

properly discontinuous cocompact simplicial action of G on P . As a consequence, if G is torsion-free, the action of G on P is free and the orbit map $P \rightarrow G \backslash P$ is a covering map, so $G \backslash P$ is a compact Eilenberg-MacLane space of type $K(G, 1)$. All three references [Bkly], [Stras], and [Swiss] give readable accounts of Rips's theorem.

5.5. In general, the minimum number of relators needed in a filling of a relation w of a finite presentation \mathcal{P} is called the area of w and is written $\text{Area}_{\mathcal{P}}(w)$. It is equal to the minimum number of factors in an expression for w as a product of conjugates of defining relators and their inverses. The equivalence of these two expressions for the area of w is a consequence of a lemma of van Kampen's and was treated in S. Ivanov's lectures at the conference.

5.6. One can estimate the area of w in the proof of Theorem 5.3, using the fact that the length of the geodesic γ_j is equal to $d(1, w(j)) \leq j$. The result is $\text{Area}_{\mathcal{P}}(w) \leq \sum_{i=1}^{\ell(w)} i \leq C\ell(w)^2$, where $\ell(w)$ is the length of the circuit w and where C is a constant. In the terminology of §6, this shows that hyperbolic groups satisfy the quadratic isoperimetric inequality. In fact, much more is true.

Theorem 5.7*. *Let $\mathcal{P} = \langle A \mid \mathcal{R} \rangle$ be any finite presentation for a hyperbolic group G . Then there exists $K > 0$ so that for all edge-circuits w in $\Gamma_{G,A}$ one has*

$$(5.7.1) \quad \text{Area}_{\mathcal{P}}(w) \leq K\ell(w).$$

Conversely, if a finitely presented group G satisfies the linear isoperimetric inequality (5.7.1) for some finite presentation \mathcal{P} of G , then G is hyperbolic.

Both assertions in Theorem 5.7 are nontrivial. I have found the treatment in [Bkly] to be useful. It is also worth remarking that Ol'shanskii gave an accessible treatment of a strengthening of the converse assertion, due originally to Gromov, that a finitely presented group satisfying a subquadratic isoperimetric inequality is hyperbolic [Olshan]. Papasoglu and Bowditch have also treated the question. I have treated the question of a cohomological interpretation of the linear isoperimetric inequality, and the final word has not yet been written on the matter.

6.0. Small cancellation groups. In this section I shall show that the classical small cancellation groups of type $C'(1/6)$ are hyperbolic, making use of a combinatorial argument I gave in the same volume where Gromov's fundamental paper [Gromov] appeared.

6.1. We consider in this section combinatorial cell complexes of dimension 2. Technically, this is just a finite 2-dimensional CW-complex X in which each attaching map f of a 2-cell is a map of a circle subdivided into a finite number of intervals such that f restricted to the interior of each such interval is a homeomorphism onto an edge of the 1-skeleton. Thus f itself need not be 1-1, but no nondegenerate subinterval of the circle is mapped to a point. A 2-cell \mathcal{F} of X is called a face, and the number of intervals into which the domain of the attaching map of \mathcal{F} is subdivided as above is denoted $n(\mathcal{F})$.

6.1.1. Example. Let $\mathcal{P} = \langle x_1, x_2, \dots, x_p \mid R_1, R_2, \dots, R_q \rangle$ be a finite presentation. Thus each R_i is a word in the free group $F(x_1, x_2, \dots, x_p)$ with free basis x_1, x_2, \dots, x_p . The 2-complex $X_{\mathcal{P}}$ canonically associated with \mathcal{P} has one 0-cell, p

1-cells e_i in 1-1 correspondence with the generators x_i each with a preferred orientation or label x_i , and q 2-cells \mathcal{F}_j in 1-1 correspondence with the relators R_j , where the attaching map of \mathcal{F}_j spells out the word R_j as a map of the circle, subdivided into $n(\mathcal{F}_j) = \ell(R_j)$ segments, to the 1-skeleton; here $\ell(R_j)$ is the length of the free word R_j .

6.2. A *corner* α of a 2-cell \mathcal{F} of X is simply one of the subdivision points of the domain of the attaching map of \mathcal{F} . It is better to think of α as an angle between two adjacent sides of a polygon with $n(\mathcal{F})$ sides, but this is just a convenient visualization. A *weight* function on X is an assignment of real numbers $w(\alpha)$ to the corners α of 2-cells of X . In this exposition we demand that $w(\alpha) > 0$ but there are situations we shall not discuss here where even this is too restrictive a condition.

6.2.1. Example. If X is a regular n -gon in the Euclidean plane, $n \geq 3$, then X has one 2-cell \mathcal{F} with $n(\mathcal{F}) = n$, and one can assign to each corner the Euclidean angle $(n-2)\pi/n$. Note that in this case the sum of the weights attached to the corners of \mathcal{F} is $(n-2)\pi$, the sum of the interior angles of a convex Euclidean n -gon.

The following result is completely elementary, although the proof involves somewhat tedious calculations.

Proposition 6.3. *Suppose that the 2-complex D is a topological 2-dimensional disc equipped with a weight function w such that*

(6.3.1) *there is an $\epsilon > 0$ so that for each interior vertex v of D the sum of the weights of corners of 2-cells incident at v is at least $2\pi + \epsilon$, and*

(6.3.2) *for each 2-cell \mathcal{F} of D the sum of the weights of corners of \mathcal{F} is at most $(n(\mathcal{F}) - 2)\pi$.*

Then $F \leq (1 + 2\pi/\epsilon)E_\infty$, where F is the number of 2-cells of D and E_∞ is the number of edges on the boundary of D .

Proof. We denote by V, V_{int}, V_∞, E , and E_{int} the number of vertices, number of interior vertices, number of boundary vertices, number of geometric edges, and number of geometric edges in the interior of D , respectively. Note that $E = E_{int} + E_\infty$, $V = V_{int} + V_\infty$, $E_\infty = V_\infty$, and $V - E + F = 1$, where the last two equalities come from the calculation of the Euler characteristics of the circle and disc as 0 and 1, respectively.

Let $S = \sum_\alpha w(\alpha)$, where the sum is over all corners α of all 2-cells of D . By (6.3.1) we have

$$(2\pi + \epsilon)V_{int} = \sum_{v \in \text{int}(D)^{(0)}} (2\pi + \epsilon) \leq S,$$

where the sum in the middle is over vertices in the interior of D . By (6.3.2) we have

$$S \leq \sum_{\mathcal{F}} (n(\mathcal{F}) - 2)\pi = \pi \sum_{\mathcal{F}} n(\mathcal{F}) - 2\pi F,$$

where the sums are over all 2-cells \mathcal{F} of D . Combining the two displayed inequalities gives

$$(6.3.3) \quad (2\pi + \epsilon)V_{int} \leq \pi \sum_{\mathcal{F}} n(\mathcal{F}) - 2\pi F.$$

Now substitute the equalities

$$\sum_{\mathcal{F}} n(\mathcal{F}) = 2E_{int} + E_{\infty} = 2E - E_{\infty}$$

and $V_{int} = V - E_{\infty}$ into (6.3.3) and manipulate to obtain

$$\epsilon V \leq (\pi + \epsilon)E_{\infty} - 2\pi(V - E + F) = (\pi + \epsilon)E_{\infty} - 2\pi \leq (\pi + \epsilon)E_{\infty},$$

or

$$(6.3.4) \quad V \leq \frac{\epsilon + \pi}{\epsilon} E_{\infty}.$$

Next note that our assumption that $w(\alpha) > 0$ for all corners α and (6.3.2) imply that $n(\mathcal{F}) \geq 3$ for all 2-cells \mathcal{F} of D . Thus $3F \leq \sum_{\mathcal{F}} n(\mathcal{F}) = 2E - E_{\infty}$, or

$$(6.3.5) \quad (3F + E_{\infty})/2 \leq E.$$

Use Euler's formula $E - F + 1 = V$ again, replace E by (6.3.5) and replace V by (6.3.4) to get

$$(3F + E_{\infty})/2 - F + 1 \leq \frac{\epsilon + \pi}{\epsilon} E_{\infty},$$

and solve to get $F \leq (1 + 2\pi/\epsilon)E_{\infty} - 2 \leq (1 + 2\pi/\epsilon)E_{\infty}$, which establishes the result.

6.4. To apply the preceding result we need the notion of a reduced disc diagram in our 2-complex X . First, a disc diagram is a combinatorial map $f : D \rightarrow X$, where D is a combinatorial cell complex whose underlying space is the 2-dimensional disc and where f is a combinatorial map, in the sense that f restricted to each open cell of D is a homeomorphism *onto* an open cell of the same dimension of X . The map f is called *reduced* if it is never the case that there are 2 2-cells $\mathcal{F}, \mathcal{F}'$ in D with an oriented edge e in common so that f maps the boundaries of these cells, read as edge-loops in $X^{(1)}$ beginning with the letter $f(e)$, to the same word in the oriented edges of X .

6.5. We can now introduce the small cancellation condition on X . Let $f : D \rightarrow X$ be a reduced disc diagram. Let \bar{D} be obtained from D by removing all *interior* vertices of valence 2 (so the boundary of D is unchanged). Let $\bar{\mathcal{F}}$ be the face of \bar{D} corresponding to the face \mathcal{F} of D and let $n(\bar{\mathcal{F}})$ be its number of corners (this is just $n(\mathcal{F})$ reduced by the number of vertices in the boundary of \mathcal{F} which are of valence 2 in the interior of D). Give the corners of $\bar{\mathcal{F}}$ the weights of a regular Euclidean $n(\bar{\mathcal{F}})$ -gon (*cf.* 6.2.1). This puts a weight function w on the corners of \bar{D} . We say that X *satisfies the small cancellation condition* if this weight function w satisfies conditions (6.3.1) and (6.3.2) for one fixed ϵ and all choices of f .⁸

⁸I have called this the condition of negative curvature in print. However that term is getting somewhat overworked and suggests some connection with geometry, whereas our weights have no *a priori* connection with geometry.

6.6. Exercise. Show that if \mathcal{P} is a finite presentation satisfying the small cancellation condition $C'(1/6)$ introduced in S. Ivanov's lectures,⁹ then the 2-complex $X_{\mathcal{P}}$ satisfies the small cancellation condition. The number ϵ in this case can be taken to be $\pi/7$; this minimum is achieved with 3 7-gons meeting at an interior vertex of \bar{D} .

Theorem 6.7. *Let \mathcal{P} be a finite presentation satisfying the small cancellation condition $C'(1/6)$. Then every reduced disc diagram $f : D \rightarrow X_{\mathcal{P}}$ satisfies the linear isoperimetric inequality*

$$F \leq 15E_{\infty}.$$

Proof. This is immediate from Proposition 6.3 and Exercise 6.6.

Corollary 6.8. *If a group G admits a finite presentation satisfying the small cancellation condition $C'(1/6)$, then G is hyperbolic.*

Proof. This is immediate from Theorems 6.7 and 5.7.

6.9. Show that the standard presentations of fundamental groups of closed orientable surfaces of genus at least 2 satisfy the small cancellation condition $C'(1/6)$. This gives another proof (cf. 3.17.5) that these groups are hyperbolic.

Let us also mention the following result proved by the same method.

Theorem 6.10. *Suppose that the finite 2-complex X is such that there is a number $\epsilon > 0$ such that every reduced disc diagram $f : D \rightarrow X$ has a weight satisfying (6.3.1) and (6.3.2) for this number ϵ . Then the fundamental group of X is hyperbolic. \square*

6.11. Example. Consider the presentation $\mathcal{P} = \langle x, y, z \mid x^2y^2z^2 \rangle$ for the fundamental group of the nonorientable surface of genus 3. This does not satisfy condition $C'(1/6)$ since each piece is exactly one-sixth the length of the defining relator. However an assignment of weight $\pi/2$ to all corners in a reduced disc diagram satisfies (6.3.1) and (6.3.2), as the reader should check, and it follows that the group of \mathcal{P} is hyperbolic.

6.12. Example.* If \mathcal{P} is a finite presentation satisfying the small cancellation condition $C'(1/6)$ and such that that no relator of \mathcal{P} is a proper power in the free group on the generators of \mathcal{P} , then the group G of the presentation is torsion-free. For let \mathcal{Q} be the presentation obtained from \mathcal{P} by choosing precisely one representative from each cyclic conjugacy class of relator or its inverse and let $X = X_{\mathcal{Q}}$. Note that the group of \mathcal{Q} is also G . The small cancellation condition implies that $\pi_2(X)$ is generated as a $\pi_1(X)$ -module by classes of 2-faced *spherical* diagrams, where a spherical diagram is a combinatorial map of a cell structure on the 2-sphere into X . But the condition that no relator is a proper power means all 2-faced spherical diagrams are null-homotopic, so it follows that $\pi_2(X) = 0$. Thus, X is aspherical in the sense that it is a $K(G, 1)$. It follows from the P. A. Smith theorem (which

⁹This means each relator of \mathcal{P} is cyclically reduced, and the length of every piece of a relator is *strictly less* than one-sixth the length of that relator, cf. [L-S]. Recall that a *piece* is the label of an arc in the interior of a reduced 2-faced disc diagram. The convention of [L-S] also requires that \mathcal{P} contain all cyclic conjugates of every relator and its inverse.

states that a group G with a finite dimensional $K(G, 1)$ is torsion free) that G is torsion-free.

6.13. A theorem of Rips's [Rips] states that given any finitely presented group G there is a short exact sequence of groups

$$1 \rightarrow N \rightarrow E \rightarrow G \rightarrow 1$$

where E has a finite presentation satisfying the small cancellation condition $C'(1/6)$ and where N is a normal subgroup which is finitely generated as a group. In Rips's construction the group N is never finitely presented except in trivial cases, so this gives examples of finitely generated subgroups of hyperbolic groups which are not finitely presented. I showed in [Gerst2] that all finitely presented subgroups of $C'(1/6)$ -groups G (and of certain other hyperbolic groups G like those of cohomological dimension 2) were hyperbolic. Recently N. Brady [Brady] has given an example of a finitely presented subgroup H of a hyperbolic group G of cohomological dimension 3 where H is not hyperbolic. Beyond these results there is almost nothing known about the subgroup structure of general hyperbolic groups.

7.0. Isoperimetric functions and Dehn functions. In this section I want to digress on isoperimetric inequalities, both as a bridge between hyperbolic and automatic groups, and because I consider these to offer an important new outlook on finitely presented groups.

7.1. Let \mathcal{P} be a finite presentation with $G = G(\mathcal{P})$ the group determined by the presentation. An isoperimetric function for \mathcal{P} is a function $h : \mathbb{N} \rightarrow \mathbb{N}$ such that for all relations w of length at most n one has $\text{Area}_{\mathcal{P}}(w) \leq h(n)$. There exists a minimal isoperimetric function for \mathcal{P} called the *Dehn function* $f_{\mathcal{P}}$, where

$$f_{\mathcal{P}}(n) = \max\{\text{Area}_{\mathcal{P}}(w) \mid \ell(w) \leq n, w \equiv 1 \text{ in } G\}.$$

Note that there are only a finite number of relations w among the generators of length at most n , so $f_{\mathcal{P}}(n)$ is a well-defined integer.

7.2. To state in what sense the Dehn function is an invariant, it is necessary to introduce an equivalence relation on functions from \mathbb{N} to \mathbb{N} . If $f, g : \mathbb{N} \rightarrow \mathbb{N}$ we write $f \preceq g$ if there exist $A, B, C, D, E > 0$ so that $f(n) \leq Ag(Bn + C) + Dn + E$ for all $n \in \mathbb{N}$. We write $f \sim g$ if both $f \preceq g$ and $g \preceq f$. It is clear that \sim is an equivalence relation.

7.3.* If \mathcal{P} and \mathcal{Q} are finite presentations for isomorphic groups, then $f_{\mathcal{P}} \sim f_{\mathcal{Q}}$, so their Dehn functions are equivalent. I established this result in [Gerst], and it was generalized in [Alon] to show that if \mathcal{P} and \mathcal{Q} are finite presentations whose Cayley graphs are quasi-isometric, then their Dehn functions are equivalent.

7.4. Show that if $d, d' \geq 1$ and if the functions $x^d \sim x^{d'}$, then $d = d'$. Thus it makes sense to say that the Dehn function is polynomial, polynomial of degree d , exponential, recursive, etc. It is not too difficult to show that a finite presentation has a solvable word problem iff its Dehn function is recursive.

7.5. The Dehn function "landscape".

7.5.1. It follows from the theorem of Gromov-Ol'shanskii [Olshan] that a subquadratic isoperimetric function implies the group is hyperbolic. I showed in [Gerst2] that if the Cayley graph is not a tree, then the Dehn function grows

at least linearly. Thus, for finite presentations of hyperbolic groups whose Cayley graphs are not trees, the Dehn function is equivalent to x , the identity function. There is no Dehn function equivalent to x^α where $1 < \alpha < 2$.

7.5.2. “The quadratic zoo”. The following groups are known to have isoperimetric functions equivalent to x^2 (so for their Dehn functions $f_{\mathcal{P}}$ we have $f_{\mathcal{P}} \preceq x^2$): automatic groups, CAT(0)-groups, and the $(2n+1)$ -dimensional integral Heisenberg groups for $n \geq 2$. I shall prove that automatic groups have quadratic isoperimetric functions in §9 below (a theorem of Thurston’s).

The integral $(2n + 1)$ -dimensional Heisenberg group is the group of integral uppertriangular $(n + 2)$ -by- $(n + 2)$ matrices with 1’s on the main diagonal and otherwise the only other nonzero entries are in the first row and last column. It was conjectured by Thurston that for $n \geq 2$ these groups had quadratic Dehn functions, and this has recently been established by D. Allcock.

Thurston also conjectured that $\mathrm{Sl}_n(\mathbb{H})$ for $n \geq 4$ has a quadratic Dehn function, but to my knowledge this is still open.

A CAT(0)-group is a group which acts properly discontinuously and cocompactly on a proper geodesic metric space (X, d) which satisfies the CAT(0) inequality. The CAT(0) inequality means the following. Let ABC be a geodesic triangle in X . Form a comparison triangle $A'B'C'$ in the Euclidean plane \mathbb{H} whose respective side lengths are equal to those of ABC , so $d(A, B) = d_{\mathbb{H}}(A', B')$, etc. Let P be a point on the side BC and let P' be the corresponding point on $B'C'$, so $d(B, P) = d_{\mathbb{H}}(B', P')$. Then it should be the case that $d(A, P) \leq d_{\mathbb{H}}(A', P')$.

I call this a zoo, because I am unable to see any pattern in this bestiary of groups. It would be striking if there existed a reasonable characterization of groups with quadratic Dehn functions, which was more enlightening than saying that they have quadratic Dehn functions.

7.5.2.5. There is no example known of a group whose Dehn function is equivalent to x^α , where $2 < \alpha < 3$ and it is an interesting open question whether such a group can exist.

7.5.3. The 3-dimensional integral Heisenberg group has Dehn function equivalent to x^3 . This is established in [Wordproc] and I give a different proof in [Gerst].

7.5.4. Exactly which real numbers $\alpha > 2$ are such that x^α is equivalent to the Dehn function of a finitely presented group is an open question at the time of writing. A step in this direction was taken by M. Bridson, who showed that there are infinitely many fractions $\alpha > 3$ so that there exist finite presentations with Dehn functions equivalent to x^α .

7.5.5. There are many examples of groups with exponential isoperimetric functions. Among them are $\mathrm{Sl}_3(\mathbb{H})$ and the Baumslag-Solitar groups $B_{p,q}$ for $1 < p < q$, where $B_{p,q} = \langle x, y \mid yx^p = x^qy \rangle$. These results are proved in [Wordproc] and I gave a different proof for $B_{p,q}$ in [Gerst].

7.5.6. I showed in [Gerst] that the Dehn function for the 1-relator presentation $\langle x, y \mid x^{(x^y)} = x^2 \rangle$ grows faster than any *iterated* exponential. Here $x^y = y^{-1}xy$. This is the world record growth so far for 1-relator groups. It can be shown that Ackermann’s function, which is recursive but not primitive recursive, is an upper bound for the equivalence class of Dehn functions of all 1-relator groups, but my example has much slower growth than Ackermann’s function. It is quite possible that my example is the fastest and indeed this has been announced to me in a

private communication. This would make an interesting complement to Magnus's result that 1-relator groups have a solvable word problem.

7.5.7. It has been shown that every recursive function appears as a lower bound for the Dehn function of some finite presentation with a solvable word problem [BMS] Corollary 18. Thus the equivalence classes of Dehn functions of finite presentations with solvable word problems have no recursive upper bound under the relation \preceq .

8.0. Automata and Cannon's Theorem. In this section I introduce finite state automata and regular languages and state the theorem of Cannon.

8.1. Let A be a finite set and let A^* be the free monoid on the set A . Thus A^* consists of all words (*i.e.* finite concatenations of letters) of the alphabet A including the empty word, which I denote by "1". The monoid operation is concatenation of words. A subset L of A^* is called a language, and, in general, if L is a language, then L^* is by definition the submonoid generated by L . If L and L' are languages, then $L + L'$ denotes their union $L \cup L'$, and LL' is the set of words ww' where $w \in L$ and $w' \in L'$. In case L consists of a single letter $a \in A$, it is traditional to denote L^* by a^* rather than by the cumbersome but correct $\{a\}^*$.

Of particular interest are the regular languages, which are those recognized by finite state automata, which we now define.

8.2. A finite state automaton (FSA) is a 5-tuple $\mathcal{A} = (\Gamma, s_0, A, \lambda, Y)$ where

- (1) Γ is a finite directed graph, with vertex set $V(\Gamma)$ and edge set $E(\Gamma)$; the vertices are called "states" and the directed edges are called "transitions";
- (2) s_0 is a distinguished vertex of Γ called the "start state";
- (3) A is a finite alphabet;
- (4) $\lambda : E(\Gamma) \rightarrow A$ is a function which we think of as labelling the edges of Γ by letters of the alphabet A ; and
- (5) $Y \subset V(\Gamma)$ is a set of states, possibly empty, called "accept states".

8.2.1. A simple example may help fix notions. Consider the directed graph shown below in Figure 6.

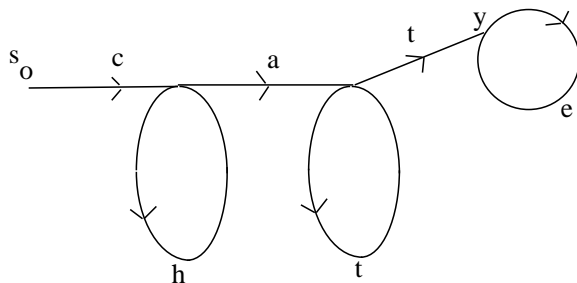

Figure 6. A Finite State Automaton

The alphabet $A = \{a, c, e, h, t\}$, $Y = \{y\}$

8.3. The language $L(\mathcal{A})$ recognized by the FSA $\mathcal{A} = \{\Gamma, s_0, A, \lambda, Y\}$ is by definition the set of labels $\lambda(p)$ of all directed paths p of Γ which begin at the start state s_0 and end at any state of Y ; here $\lambda(p)$ is the concatenation of the labels of the edges of p in order. A sublanguage L of A^* which is of the form $L(\mathcal{A})$ for some FSA \mathcal{A} with alphabet A is called a *regular language*.

For example, in the FSA of Figure 6, we have $L(\mathcal{A}) = ch^*att^*e^* = \{ch^m at^{n+1}e^p \mid m, n, p \geq 0\}$.

8.4. Before stating the theorem of Cannon, it is necessary to say some words about generators. Previously we used a set of group theoretic generators to define the edges of Cayley graph, but even there we needed inverses to generate enough paths to connect vertices. For example, if we take an infinite cyclic group $\langle t \rangle$ with generating set $\{t\}$, then there is no edge-path beginning at the vertex t^2 , ending at the vertex t , and labelled by positive powers of t . However in discussing languages, we are discussing subsets of free monoids which only involve positive expressions in the free generators.

To remedy the problem, we let X be a finite set of group theoretic generators for the finitely generated group G and let $A = X \cup X^{-1}$, a finite set of semigroup generators for G . Let A^* be the free monoid on the set A and let $\mu : A^* \rightarrow G$ be the evaluation map, which takes a word and evaluates it using the product operation in G . The map μ is surjective precisely because A was constructed as a set of semigroup generators for G .

Theorem 8.5* (J. W. Cannon). *Let X be a finite set of generators for the hyperbolic group G and let $A = X \cup X^{-1}$. Let L be the set of geodesic words of A^* , so L is the set of labels of geodesic edge-paths in the Cayley graph $\Gamma_{G,X}$. Then L is a regular sublanguage of A^* .*

A short and very readable proof of this result which is patterned after an argument due to Thurston can be found in [BGSS] Theorem 6.2.

8.5. Example. Let $F = F(c, d)$ be the free group with free basis $\{c, d\}$. Let $A = \{c, C, d, D\}$ and let $\mu : A^* \rightarrow F$ be given by $c \mapsto c$, $C \mapsto c^{-1}$, $d \mapsto d$, and $D \mapsto d^{-1}$. The geodesic words in the alphabet A are just the reduced words, where a word is called reduced if it contains no subword of the form cC , Cc , dD , or Dd . A FSA with alphabet A whose language is the set of reduced words is shown below in Figure 7. In this example every state is an accept state.

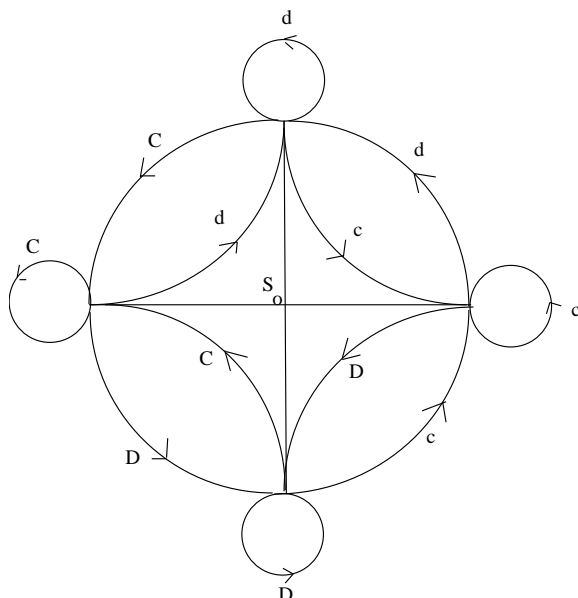

Figure 7. Automaton generating all reduced words

8.6. If G is a hyperbolic group and X is a finite set of generators for G then the

Cayley graph $\Gamma_{G,X}$ is δ -hyperbolic for some $\delta \geq 0$. If $A = X \cup X^{-1}$, we have already seen that if γ, γ' are geodesic words in A^* considered as paths beginning at 1 in $\Gamma_{G,X}$ and if the end points of these geodesics are at most a unit apart, then there exists $k > 0$ so that $d(\gamma(i), \gamma'(i)) \leq k$ for all $i \in \mathbb{Z}$. In fact we can take $k = 2(\delta + 1)$ by Lemma 5.1. This property of geodesics is called the *k-fellow traveller property*.

These properties of hyperbolic groups, a regular language of normal forms for all group elements possessing the *k-fellow traveller property* for some $k > 0$, will be abstracted to define the notion of an automatic structure in the next section.

9.0. Automatic groups.

9.1. Definition. An automatic structure (A, L) on a finitely generated group G is

- (9.1.1) a finite set A of semigroup generators, so the evaluation map $\mu : A^* \rightarrow G$ is surjective, and a regular language $L \subset A^*$ so that $\mu(L) = G$, such that
- (9.1.2) there exists a number $k > 0$ so that if $p, p' \in L$ are such that $d(\mu(p), \mu(p')) \leq 1$ in the word metric d of the Cayley graph $\Gamma_{G,A}$, then p and p' , thought of as labels of paths starting at the same vertex of $\Gamma_{G,A}$, satisfy the *k-fellow traveller property*.

We can think of L as a set normal forms for elements of G , and (9.1.1) says we have a regular language of normal forms for all group elements. By (9.1.2) if the paths $p, p' \in L$ begin at the same vertex and end at most a unit apart, then $d(p(i), p'(i)) \leq k$ for all $i \in \mathbb{Z}$ (recall the convention 5.0 about extending the domain of edge-paths to \mathbb{Z}). In particular, there may be many normal forms for the same group element, but all such are *k-fellow travellers*.

9.2. Examples

9.2.1. The theorem of Cannon assures us that if A is a symmetric set of generators for the hyperbolic group G , then the set L of those words in A^* which are labels of geodesics in $\Gamma_{G,A}$ is an automatic structure on G .

9.2.2. Let $G = \mathbb{Z}^2$ with semigroup generators $c = (1, 0)$, $C = (-1, 0)$, $d = (0, 1)$, and $D = (0, -1)$, so $A = \{c, C, d, D\}$. Let $L = c^*d^* + c^*D^* + C^*d^* + C^*D^*$. Then (A, L) is an automatic structure for G . Those who know something about regular languages will recognize that L is given by a “regular expression”, which defines a regular language. However it is easy enough to see that L is the language recognized by the FSA in Figure 8 below; Y is the set of all states in this machine.

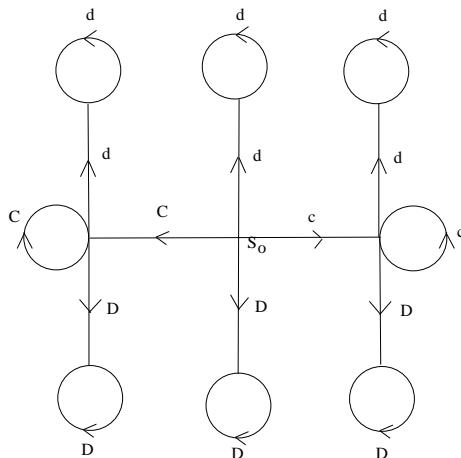

Figure 8. Automatic language for \mathbb{Z}^2

In terms of the square lattice in \mathbb{R}^2 , the language L can be described as the language of geodesics doing all horizontal movement before doing any vertical movement. Note that each group element has a unique normal form in this language.

It remains to verify the k -fellow traveller property for suitable $k > 0$. We shall carry out the verification for $p, p' \in L$ representing points in the first quadrant; the other cases work the same way. Consider then $p = c^m d^n$ and $p' = c^{m+1} d^n$ where $m, n \geq 0$ thought of as paths from the origin. These paths agree for $t \leq m$, then diverge. But for $t = i > m$, $i \in \mathbb{R}$, $i \leq m + n$, we have $p(i) = c^m d^{i-m}$ and $p'(i) = c^{m+1} d^{i-m-1}$. We see that the distance in the word metric between these group elements is 2, so the paths are 2-fellow travellers. There is also the case $p = c^m d^n$ and $p' = c^m d^{n+1}$ to consider, but it is clear these paths are 1-fellow travellers. Thus $k = 2$ and the language L satisfy the 2-fellow traveller property.

9.3. In order to see that the property of having an automatic structure is independent of generators, one shows that an automatic structure (A, L) defined for one set of semigroup generators for G can be translated into an automatic structure for a second finite set A' of semigroup generators. The verifications are carried out in [Wordproc]. It is then permissible to define a finitely generated group as being automatic if for one, and hence for every, finite set A of semigroup generators there is a regular language L of normal forms for all group elements satisfying the k -fellow traveller property for some $k > 0$.

9.4. Automatic groups are closed under the operations of taking finite index subgroups and finite extensions. The direct product and free product of two automatic groups is also automatic. Curiously, it is unknown whether a direct factor of an automatic group is automatic, although a free factor of one is always automatic. These facts are proved in [Wordproc] and in [BGSS]. Another curiosity is that in January 1989 we held a seminar at MSRI on automatic groups and I edited a set of problems from that seminar which is published in [Gerst3]; all those problems as originally posed are still open, although partial results have been obtained, and some of the problems have been solved in the setting of biautomatic groups, which I will not have time to treat here.

9.4.1. Example.* Consider the Euclidean Escher diagram Figure 1. The symmetry group G of this tessellation of \mathbb{R}^2 has a precompact fundamental domain, so it follows from the Bieberbach theorem¹⁰ that G contains a subgroup of finite index isomorphic to \mathbb{Z}^2 . It follows from 9.4 that G is automatic.

9.5. Automatic groups have been appearing sporadically in odd contexts. All lattices in the Lie groups $SO(n, 1)$, all Coxeter groups, and Artin groups associated to the finite Coxeter groups are automatic. Perhaps the most striking result in the area, due to L. Mosher, is that all mapping class groups of surfaces of finite type (*i.e.* closed surfaces with a finite number of punctures) are automatic. However $\text{Out}(F_3)$ is not automatic, as was shown by K. Vogtmann, basing her work on Thurston's argument that $\text{Sl}_3(\mathbb{R})$ is not automatic. It remains to be clarified where this notion fits into the general problem of understanding finitely presented groups.

¹⁰This states that if G is a subgroup of the group of isometries of Euclidean space \mathbb{R}^n which acts properly discontinuously and cocompactly, then G contains a subgroup of translations which is of finite index in G and is isomorphic to \mathbb{Z}^n .

9.6. Automatic groups are finitely presented. In fact, the proof I gave in §5 that hyperbolic groups are finitely presented only used the k -fellow traveller property, and hence applies without change to automatic groups. It follows from that argument that if (A, L) is an automatic structure for G with L satisfying the k -fellow traveller property, then $\mathcal{P} = \langle A \mid \mathcal{R} \rangle$ is a finite presentation for G , where \mathcal{R} is the set of labels of all edge-loops in the Cayley graph $\Gamma_{G,A}$ of length at most $2k + 2$.

It might appear that the same argument would prove the quadratic isoperimetric inequality, but there is a sticking point. In the case of hyperbolic groups, the coning argument in Theorem 5.3 used geodesics, and one always has a bound on the lengths of geodesics, and hence a bound for the number of relators Q_{ij} there. However if we try to cone using the normal forms p in a regular language, we quickly find that there is no bound in general on the length of p in terms of $d(1, \mu(p))$. I want to spend the remaining time showing how to fix this problem and proving

Theorem 9.7. *An automatic group satisfies the quadratic isoperimetric inequality.*

The proof makes use of two lemmas. We say that (A, L') is an automatic substructure of the automatic structure (A, L) for the group G if L' is a regular sublanguage contained in L which is mapped onto G . If L has the k -fellow traveller property, it follows that L' also has the k -fellow traveller property with the same k .

Lemma 9.7.1. *Each automatic structure (A, L) for the group G contains an automatic substructure (A, L') , whose language L' is mapped bijectively by the evaluation mapping onto G .*

One orders the alphabet A and takes the lexicographically least representative for each group element in L . This defines L' and it is clearly mapped bijectively onto G by the evaluation mapping. For the proof that L' is regular, see [Wordproc] 2.5 or [BGSS] Prop. 1.3 page 255.

Lemma 9.7.2. *If (A, L) is an automatic structure for the group G such that the evaluation mapping μ maps L bijectively onto G , then there exists $M > 0$ so that for all pairs $w, w' \in L$ with $d(\mu(w), \mu(w')) = 1$ one has $|\ell(w) - \ell(w')| \leq M$.*

Proof. Assume the conclusion is false, so that one can find pairs of words $w, w' \in L$ which evaluate in G a unit apart with w' arbitrarily longer than w . Let \mathcal{A} be a FSA with alphabet A which recognizes the language L , and let L satisfy the k -fellow traveller property. If $\ell(w) = n$, then for all $i > 0$ one has $d(w(n), w'(n + i)) \leq k$. But the ball of radius k about 1 in $\Gamma_{G,A}$ is finite and there are only a finite number of states in the FSA \mathcal{A} , so if $\ell(w') \gg \ell(w)$, then there must exist integers $i < j$ with $0 < i < j < \ell(w') - \ell(w)$ so that $w'(j)$ and $w'(i)$ represent the same element of G and such that the word w' is in the same state of the machine \mathcal{A} at time i as at time j . But then the string w' makes a loop in the machine between times i and j and the label of this loop is the identity element of G . However this means that you can go around this loop any number of times and still get to an accept state of \mathcal{A} , thereby generating the same element $\mu(w')$ of G infinitely often. In other words, L is not mapped bijectively onto G by μ , a contradiction.

It follows that the difference $|\ell(w) - \ell(w')|$ is bounded if one considers all pairs $w, w' \in L$ which evaluate a unit apart in G , and the Lemma is established.

We can now give the proof of Theorem 9.7. By Lemma 9.7.1 there is an automatic structure (A, L) for G where the evaluation mapping maps L bijectively onto G . By Lemma 9.7.2 elements of L which evaluate to group elements a unit apart differ in length by no more than some fixed constant M . Assume that L satisfies the k -fellow traveller property.

From 9.6 we know that the set of labels of all loops in $\Gamma_{G,A}$ of length at most $2k + 2$ is a defining set of relations among the generators A . Suppose now that w is an edge-loop in $\Gamma_{G,A}$ with $w(0) = 1$. We come from the identity element, in this case not by geodesics, but rather we choose for each $0 \leq i \leq \ell(w)$ the unique element $p_i \in L$ which evaluates to $w(i)$ in G . The same picture, Figure 5, applies here and may help to visualize the argument. Using Lemma 9.7.2 and induction we see that $\ell(p_i) \leq Mi$ for each i . It follows that the strip between p_i, p_{i+1} and the edge of w has area at most Mi . Thus we can fill w using at most $\sum_{i=0}^{\ell(w)-1} Mi \leq C\ell(w)^2$ defining relators, where C is a constant independent of w . This establishes the quadratic isoperimetric inequality.

REFERENCES

- [Alon] J. Alonso, *Inégalités isopérimétriques et quasi-isométries*, C. R. Acad. Sci. Paris, Série I **311** (1991), 761–764.
- [Beard] A. F. Beardon, *The Geometry of Discrete Groups*, Springer-Verlag, 1983.
- [BGSS] G. Baumslag, S. M. Gersten, M. Shapiro, and H. Short, *Automatic groups and amalgams*, Jour. Pure Appl. Alg. **76** (1991), 229–316.
- [BMS] G. Baumslag, C. F. Miller III, and H. Short, *Isoperimetric inequalities and the homology of groups*, Invent. Math. **113** (1993), 531–560.
- [Bndry] M. Bestvina, *Boundary of hyperbolic groups*, Notes on seminar lectures taken by J. Burillo, <http://www.math.utah.edu/~gersten/MaxDehnSeminar/burillo.dvi>.
- [Bkly] J. Alonso, T. Brady, D. Cooper, V. Ferlini, M. Lustig, M. Mihalik, M. Shapiro, and H. Short, *Notes on word hyperbolic groups*, Group Theory from a Geometrical Viewpoint (H. Short, ed.), eds. E. Ghys, A. Haefliger, and A. Verjovsky, World Scientific, Singapore, 1991, pp. 3–63.
- [Brady] N. Brady, *Branched coverings of cubical complexes and subgroups of hyperbolic groups*, preprint, Univ. of Utah, Sept. 1995.
- [Gerst] S. M. Gersten, *Dehn functions and ℓ_1 -norms of finite presentations*, Algorithms and Classification in Combinatorial Group Theory (G. Baumslag and C. F. Miller III, eds.), MSRI series, vol. 23, Springer-Verlag, 1992, pp. 195–224.
- [Gerst2] S. M. Gersten, *Subgroups of word hyperbolic groups in dimension 2*, to appear in Jour. London Math. Soc., preprint available electronically at my home page <http://www.math.utah.edu/~gersten>.
- [Gerst3] S. M. Gersten, *Problems on automatic groups*, Algorithms and Classification in Combinatorial Group Theory (G. Baumslag and C. F. Miller III, eds.), MSRI series, vol. 23, Springer-Verlag, 1992, pp. 225–232.
- [Gromov] M. Gromov, *Hyperbolic groups*, Essays in Group Theory (S. M. Gersten, ed.), M.S.R.I. series, vol. 8, Springer-Verlag, 1987, pp. 75–263.
- [L-S] R. C. Lyndon and P. E. Schupp, *Combinatorial Group Theory*, Springer-Verlag, 1977.
- [Olshan] A. Yu. Ol’shanskii, *Hyperbolicity of groups with subquadratic isoperimetric inequality*, Inter. Jour. of Alg. and Computation **1** (1991), 281–290.
- [Papa] P. Papasoglu, *Strongly geodesically automatic groups are hyperbolic*, Inv. Math. **121** (1995), 323–334.
- [Rips] E. Rips, *Subgroups of small cancellation groups*, Bull. London Math. Soc. **14** (1982), 45–47.
- [Stras] M. Coornaert, T. Delzant, and A. Papadopoulos, *Notes sur les groupes hyperboliques de Gromov*, Lecture Notes in Math., vol. 1441, Springer-Verlag, 1990.

- [Swiss] E. Ghys and P. de la Harpe (editors), *Sur les groupes hyperboliques d'après Mikhael Gromov*, Progress in Math. series, vol. 83, Birkhäuser, 1990.
- [Wordproc] J. W. Cannon, D. B. A. Epstein, D. F. Holt, S. V. F. Levy, M. S. Paterson, and W. P. Thurston, *Word Processing in Groups*, Jones and Bartlett, Boston, 1992.

MATHEMATICS DEPARTMENT, UNIVERSITY OF UTAH, SALT LAKE CITY, UT 84112, USA
E-mail address: gersten@math.utah.edu