

Some duality conjectures for finite graphs and their group theoretic consequences

S. M. Gersten and T. R. Riley

March 1, 2003; revised August 11, 2004

Abstract

We pose some graph theoretic conjectures about duality and the diameter of maximal trees in planar graphs, and we give innovations in the following two topics in Geometric Group Theory, where the conjectures have applications.

(i.) **Central Extensions.** We describe an *electrostatic model* concerning how van Kampen diagrams change when one takes a central extension of a group. Modulo the conjectures, this leads to a new proof that finitely generated class c nilpotent groups admit degree $c + 1$ polynomial isoperimetric functions.

(ii.) **Filling functions.** We collate and extend results about interrelationships between filling functions for finite presentations of groups. We use the *electrostatic model* in proving that the *gallery length* filling function, which measures the diameter of the duals of diagrams, is qualitatively the same as a filling function $D\log A$, concerning the sum of the diameter with the logarithm of the area of a diagram. We show that the conjectures imply that the space-complexity filling function *filling length* essentially equates to *gallery length*. We give linear upper bounds on these functions for a number of classes of groups including fundamental groups of compact geometrisable 3-manifolds, certain graphs of groups, and almost convex groups. Also we define *restricted filling functions* which concern diagrams with uniformly bounded vertex valence, and we show that, assuming the conjectures, they reduce to just two filling functions – the analogues of non-deterministic space and time.

2000 Mathematics Subject Classification: 20F05, 20F06, 57M05, 57M20

Key words and phrases: diagram, isoperimetric function, gallery length, van Kampen diagram, central extension, planar graph, duality

CONTENTS

- SECTION 1. Introduction
- SECTION 2. The graph theoretic conjectures
- SECTION 3. Examples
- SECTION 4. Singular disc diagrams
 - *a conjecture concerning diagram measurements*
- SECTION 5. Filling functions for finite presentations
- SECTION 6. The geometry of central extensions
 - *the electrostatic model*
- SECTION 7. Controlling gallery length using DlogA
- SECTION 8. Estimates on gallery length and filling length
 - *quasi-isometry invariance, groups with polynomial Dehn functions, asynchronously combable groups, almost convex groups, conjectures concerning the Dehn and filling length functions of linear groups and of polycyclic groups*
- SECTION 9. Relationships between filling functions
- SECTION 10. Restricted filling functions
 - *the geometry of fillings by van Kampen diagrams of uniformly bounded valence*

1 Introduction

We begin by presenting one of the graph theoretic conjectures originating in our work in Geometric Group Theory.

Suppose G is a finite, connected, undirected graph¹ embedded² in the 2-sphere (whence G is planar). Let G^* be the dual graph to G (see Section 4). Given a maximal³ tree T in G , define T^* to be the subgraph of G^* made up of edges dual to edges in $G \setminus T$. Refer to (T, T^*) as a *complementary pair* of maximal trees on account of the following (easy) lemma.

Lemma 1.1. *The graph T^* is a maximal tree in G^* .*

¹We allow *graphs* to have multiple edges between two vertices and to have edges that meet only one vertex, thereby forming a loop. Thus G may be what is referred to as a *multigraph* in [7].

²To avoid pathologies we assume here, and elsewhere without further comment, that each edge is embedded as a concatenation of finitely many geodesic arcs.

³A *maximal* tree (*a.k.a.* a *spanning* tree) in a connected graph G is a *subtree* such that if one included any further edge of G then the resulting graph would no longer be a tree.

Figure 1 in Section 3 shows two examples of complementary pairs (T, T^*) in a graph G . The tree T is drawn with heavy lines and T^* with dotted lines.

We endow G with the combinatorial metric in which each edge has length 1. The diameter $\text{Diam}(G)$ is the maximum distance between pairs of vertices of the graph. It is not hard to construct a maximal tree T in a connected graph G in such a way that T has diameter closely related to the diameter of G . Specifically, choose a base vertex v_0 in G and take T to be a maximal geodesic tree based at v_0 . Then $\text{Diam}(G) \leq \text{Diam}(T) \leq 2 \text{Diam}(G)$.

Our concern is with the existence of a complementary pair of trees (T, T^*) that *both* have similarly controlled diameters. The first of our conjectures is below. Others are listed in Section 2 which is followed by some examples in Section 3 and then a reformulation in the language of *diagrams* in Section 4.

Conjecture 2.1. *Fix any $\lambda > 0$. There exists some constant $K > 0$, depending only on λ , with the following property. Suppose that G is a finite, connected graph embedded in the 2-sphere, and that the valence⁴ of each vertex in G^* is at most λ . Then there is a maximal tree T in G with*

$$\begin{aligned} \text{Diam}(T) &\leq K \text{Diam}(G), \text{ and} \\ \text{Diam}(T^*) &\leq K \text{Diam}(G^*). \end{aligned}$$

A reason we became interested in these questions is that if true they imply the following, whose applications we will explain.

Conjecture 5.4. *The filling functions $\text{GL}_{\mathcal{P}}$ and $\text{DGL}_{\mathcal{P}}$ for any given finite group presentation \mathcal{P} are \simeq -equivalent.*

This says that a *filling function* $\text{DGL}_{\mathcal{P}}$ for finite presentations of groups reduces to a simpler *filling function* $\text{GL}_{\mathcal{P}}$ called *gallery length*. Careful definitions of these terms can be found in Section 5; what follows is a brief overview.

Let \mathcal{P} be a finite presentation of a group Γ . The *word problem for \mathcal{P}* , as posed by Dehn [6] towards the beginning of last century, asks for a systematic

⁴The valence λ of a vertex v in G is the number of connected components of $(G \setminus v) \cap B_v(\varepsilon)$, the intersection of $G \setminus v$ with a small neighbourhood of v . Equivalently, λ is the length of the boundary circuit of the face v^* dual to v . (This is different from the number of edges in the boundary of the face in the event that there is an edge in G that forms a loop based at v .)

method (since interpreted as an *algorithm*) to determine, given a word w in the generators, whether or not w represents 1 in Γ . This began a rich seam in Combinatorial and Geometric Group Theory, remarkably involving not only issues of undecidability and algorithmic complexity but also geometry and topology (illuminated most vividly by Gromov in [14]).

Filling functions $\mathbb{N} \rightarrow \mathbb{N}$ capture aspects of the *geometry of the word problem* for a presentation \mathcal{P} of a group Γ . They concern *van Kampen diagrams*, which are connected, planar 2-complexes that provide graphical demonstrations of how words w that represent the identity in Γ are consequences of the defining relations in \mathcal{P} . *Filling functions* arise from measuring different aspects of the geometry of *van Kampen diagrams*. The most well known is $\text{Area}_{\mathcal{P}}(n)$ and is referred to as the *Dehn function* or *minimal isoperimetric function* for \mathcal{P} . It is the minimum number K such that all words w of length at most n that represent 1 in Γ admit a van Kampen diagram with at most K 2-cells. The 1-skeleton G of a *van Kampen diagram* D is a finite, planar graph and so falls within the scope of our conjectures. The *gallery length* filling function $\text{GL}_{\mathcal{P}}(n)$ measures the diameter of G^* . And $\text{DGL}_{\mathcal{P}}(n)$ measures the minimal value of $\text{Diam}(T) + \text{Diam}(T^*)$ ranging over all complementary pairs of maximal trees for G .

If true, the graph theoretic conjectures would allow us to control $\text{Diam}(T)$ in terms of $\text{Diam}(T^*)$. It would follow that $\text{DGL}(n)$ is qualitatively the same function as $\text{GL}(n)$, and that is the content of Conjecture 5.4.

A first application is set out in Section 6. It concerns central extensions $\hat{\Gamma}$ of groups Γ . We give an *electrostatic model* for obtaining van Kampen diagrams with respect to a finite presentation $\hat{\mathcal{P}}$ for $\hat{\Gamma}$ by *blowing up* van Kampen diagrams for words in a finite presentation \mathcal{P} for Γ . An analysis of the change in the geometry of van Kampen diagrams in this procedure leads to Theorem 6.3, which shows how *simultaneously realisable* bounds on the filling functions $\text{Area}_{\mathcal{P}}(n)$ and $\text{GL}_{\mathcal{P}}(n)$ for \mathcal{P} yield *simultaneously realisable* bounds on the filling functions $\text{Area}_{\hat{\mathcal{P}}}(n)$ and $\text{DGL}_{\hat{\mathcal{P}}}(n)$ for $\hat{\mathcal{P}}$.

Theorem 6.3. *Suppose that $1 \rightarrow \Lambda \rightarrow \hat{\Gamma} \rightarrow \Gamma \rightarrow 1$ is a central extension of the finitely presented group Γ , and that (f, g) is an $(\text{Area}, \text{DGL})$ -pair for a finite presentation \mathcal{P} of Γ .*

- *If $\Lambda = \mathbb{Z}$ then, up to a common multiplicative constant, $(f(n)g(n) + n^2, g(n) + n)$ is an (Area, GL) -pair for the finite presentation $\hat{\mathcal{P}}$ of Proposition 6.1 for $\hat{\Gamma}$.*

- If $\Lambda = C_q$, a finite cyclic group of order q , then, up to a common multiplicative constant, $(f(n) + n, g(n) + n)$ is an (Area, GL)-pair for the finite presentation \hat{P} of Proposition 6.2 for $\hat{\Gamma}$.

If Conjecture 5.4 is true then we can simplify this theorem by replacing $DGL_{\hat{P}}(n)$ by $GL_{\hat{P}}(n)$. This would make the result applicable iteratively, and therefore we would be able to constrain both the Dehn function and the gallery length function as one takes successive central extensions. As a corollary we would reproduce the result of [10], [14], [15] that finitely generated nilpotent groups of class c admit polynomial isoperimetric functions of degree $c + 1$.

A second application concerns a filling function $FL_{\mathcal{P}} : \mathbb{N} \rightarrow \mathbb{N}$ known as the *filling length function* of a finite presentation \mathcal{P} . The *filling length* of a diagram D is the minimal upper bound on the length of the boundary curve in the course of a *shelling* (*combinatorial null-homotopy*) of D down to its base vertex. And $FL_{\mathcal{P}}(w)$ for a word w that represents 1 in the group presented by \mathcal{P} is the minimum of $FL(D)$ over all van Kampen diagrams D for w . And then $FL_{\mathcal{P}}(n)$ is the maximum of $FL_{\mathcal{P}}(w)$ quantifying over all words w of length at most n that represent 1 in the group. It is possible to interpret $FL_{\mathcal{P}}$ as the non-deterministic space-complexity of a naive approach to solving the word problem for \mathcal{P} in which relators are applied exhaustively – see Section 5 or [10] for more details.

We proved in Theorem 7.1 of [13] that $FL_{\mathcal{P}} \simeq DGL_{\mathcal{P}}$ under the technical hypothesis that \mathcal{P} is *fat* (Definition 5.5), and so these two filling functions are the qualitatively the same. If $DGL_{\mathcal{P}} \simeq GL_{\mathcal{P}}$ then we deduce (relevant definitions are given in detail in Section 5):

Theorem 1.2. *Let \mathcal{P} be a finite fat presentation. Assuming Conjecture 5.4 holds, the filling functions $FL_{\mathcal{P}}, GL_{\mathcal{P}} : \mathbb{N} \rightarrow \mathbb{N}$ for \mathcal{P} satisfy $FL_{\mathcal{P}} \simeq GL_{\mathcal{P}}$.*

Thus Conjecture 5.4 allows us to re-express $FL_{\mathcal{P}}$ (already a ubiquitous concept as it is both a space-complexity measure and a differential-geometric invariant controlling the length of curves in null-homotopies) in attractive and concise geometric/combinatorial terms as a measure of the diameter of the duals of the 1-skeleta of van Kampen diagrams.

The *electrostatic model* used again in Section 7. We show that a filling function $DlogA_{\mathcal{P}}$ that measures the sum of the diameter with the logarithm of the area of a diagram, is qualitatively the same as $GL_{\mathcal{P}}$:

Theorem 7.1. *If \mathcal{P} is a fat finite presentation then its filling functions $\text{GL}_{\mathcal{P}}$ and $\text{DlogA}_{\mathcal{P}}$ satisfy $\text{GL}_{\mathcal{P}} \simeq \text{DlogA}_{\mathcal{P}}$.*

This theorem facilitates proofs in Section 8 of the following two results.

Theorem 8.1. *Suppose \mathcal{P} and \mathcal{Q} are finite presentations for quasi-isometric groups. Then $\text{FL}_{\mathcal{P}} \simeq \text{FL}_{\mathcal{Q}}$. If, in addition, \mathcal{P} and \mathcal{Q} are both fat then $\text{GL}_{\mathcal{P}} \simeq \text{GL}_{\mathcal{Q}}$.*

Theorem 8.2.

8.2.1. *The gallery length function of any finite presentation of a group admitting a polynomial isoperimetric inequality of degree $d \geq 2$ admits a polynomial upper bound of degree $d - 1$.*

8.2.2. *The gallery length function of the presentation $\langle x, y, s, t \mid [x, y] = 1, txt^{-1} = x^2, sys^{-1} = y^2 \rangle$, due to Bridson, admits a linear upper bound.*

If Conjecture 5.4 holds then the filling length functions admit the same upper bounds.

In Section 8 we also establish linear upper bounds on the filling length functions for a number of classes of groups:

Theorem 8.3. *Asynchronously combable groups have filling length functions admitting linear upper bounds. This includes*

8.3.1. *Fundamental groups of finite graphs of groups with finitely generated free vertex and edge groups (for example, the Baumslag-Solitar group $\text{BS}(p, q) = \langle x, y \mid y^{-1}x^py = x^q \rangle$).*

8.3.2. *Fundamental groups of compact, geometrizable 3-manifolds.*

8.3.3. *Split extensions of a hyperbolic or abelian groups by an asynchronously combable groups.*

Theorem 8.4. *The filling length function of any group Γ that has a finite presentation $\mathcal{P} = \langle \mathcal{A} \mid \mathcal{R} \rangle$ satisfying Cannon's almost convexity condition $\text{AC}(2)$ admits a linear upper bound.*

And we ask questions about uniform bounds on the Dehn function and filling length function in larger classes of groups.

In Section 9 we collate the known results about the bounds that exist between filling functions for an arbitrary finite presentations, and we explain the simplifying impact of Theorem 1.2 (modulo Conjecture 4.3 or 5.4).

In Section 10 we introduce and examine the theory of *restricted filling functions*. These concern measurements of van Kampen diagrams that have uniformly bounded vertex valences – *i.e.* diagrams whose *curvature* is uniformly bounded away from $-\infty$. In the course of the proof of Theorem 7.1 in Section 7 we show that every word that represents the identity in a *fat* presentation admits a van Kampen diagram in which every vertex has valence at most 12. Moreover, we have considerable control on the geometry of this diagram. This enables us to understand how the *restricted* analogues of the filling functions interrelate. We set out the results in Theorem 10.3. If Conjecture 4.3 holds then all the filling functions we consider collapse to just two – the (restricted analogues of) space and time complexity filling functions $FL_{\mathcal{P}}$ and $Area_{\mathcal{P}}$.

This is the second article in a series that began with [13], in which we showed some of the ways in which duality considerations impact the study of diagrams and filling functions. We hope⁵ to complete the series with a third article containing proofs of the conjectures in Section 2.

2 The graph theoretic conjectures

Four conjectures are set out below, using the notation established in Section 1. Two further conjectures appear in this paper. One, in Section 4, is phrased in the language of *diagram measurements* and the another, in Section 5, and concerns *filling functions*. Proposition 2.5 summarises the known interrelationships.

Conjecture 2.1. *Fix any $\lambda > 0$. There exists some constant $K > 0$, depending only on λ , with the following property. Suppose that G is a finite,*

⁵*Remark added August 2004.* The conjectures remain resistant to resolution more than three years after a version was first publicised by the first author talking in the *Workshop on Geometric Group Theory* at the CRM in Montreal, July 2001. Indeed it is unknown whether the following statement, which is Conjecture 2.1 with reference to λ removed, is true: there exists $K > 0$ such that if G is a finite, connected graph embedded in the 2-sphere then there is a maximal tree T in G such that $\text{Diam}(T) \leq K \text{Diam}(G)$ and $\text{Diam}(T^*) \leq K \text{Diam}(G^*)$.

connected graph embedded in the 2-sphere, and that the valence of each vertex in G^* is at most λ . Then there is a maximal tree T in G with

$$\begin{aligned} \text{Diam}(T) &\leq K \text{Diam}(G), \text{ and} \\ \text{Diam}(T^*) &\leq K \text{Diam}(G^*). \end{aligned}$$

Conjecture 2.2. Fix any $\lambda > 0$. There exists some constant $K > 0$ such that, with the same hypotheses as Conjecture 2.1, we can find a maximal tree T in G with

$$\max \{ \text{Diam}(T), \text{Diam}(T^*) \} \leq K \text{Diam}(G^*) + K.$$

Conjecture 2.3. The conclusion of Conjecture 2.1 holds if we additionally require the valence of every vertex in both G and G^* to be at most λ .

Conjecture 2.4. Fix any $\lambda > 0$. There exists some constant $K > 0$, depending only on λ , with the following property. Suppose that G is a finite, connected graph embedded in the 2-sphere and that the valence of every vertex in G^* is at most λ with the possible exception of one vertex e_∞^* . Define n to be the valence of e_∞^* in G^* . Then there is a maximal tree T in G with

$$\max \{ \text{Diam}(T), \text{Diam}(T^*) \} \leq K (\text{Diam}(G^*) + n). \quad (1)$$

Proposition 2.5. The following implications between the conjectures hold.

$$\begin{array}{c} 2.1 \Rightarrow 2.2 \Rightarrow 2.3 \\ \uparrow \\ 2.4 \Leftrightarrow 4.3 \Rightarrow 5.4 \end{array}$$

Proof. If G is a graph as per Conjecture 2.1 then we can find a path in G between given vertices a and b by taking \bar{a} and \bar{b} to be vertices of G^* dual to 2-cells that have a and b (resp.) on their boundaries, and then follow a path in the 1-skeleton of the union of 2-cells dual to the vertices on a geodesic in G^* from \bar{a} to \bar{b} . So $\text{Diam}(G) \leq \lambda (\text{Diam}(G^*) + 1)$. Thus Conjecture 2.1 implies Conjecture 2.2.

All the other implications are immediate from the definitions. ■

It is not hard to verify that Conjectures 2.1–2.4 hold when $\lambda < 3$. It would seem that the full intricacy of these conjectures is contained in the

case $\lambda = 3$. Establishing Conjecture 2.4 for $\lambda = 3$ is sufficient for the group theoretic applications in this article on account of the well-known technique of *triangulating* a finite presentation $\mathcal{P} = \langle \mathcal{A} | \mathcal{R} \rangle$ of a group Γ : obtain a new finite presentation for Γ in which every relator has length at most three by a finite sequence of the following operations. If some $r \in \mathcal{R}$ is a concatenation $w_1 w_2$ of two words w_1 and w_2 both of length at least 2, then add a new generator a to \mathcal{A} , and in \mathcal{R} replace r by the two words $a^{-1} w_1$ and aw_2 .

3 Examples

Figure 1 shows the fourth of a family G_n of planar graphs that have $2^n + 1$ vertices. The vertex valences of the dual graphs G_n^* are at most three. So G_n falls under the scope of Conjectures 2.1 and 2.2. In the left-hand figure we show T^* , a maximal geodesic tree in G_n^* based at the vertex *at infinity*, (drawn with dotted lines). The diameter of T^* is $2n$. The complementary maximal tree T in G_n (drawn with heavy lines) has diameter 2^n . The right-hand diagram shows a different complementary pair of maximal trees (T, T^*) . Here $\text{Diam}(T) = 2n - 1$ and $\text{Diam}(T^*) = 2n$. Thus this family of examples shows that in order to satisfy the demands of Conjectures 2.1 and 2.2, it does not suffice to take the maximal trees in the dual graphs to be geodesic trees.

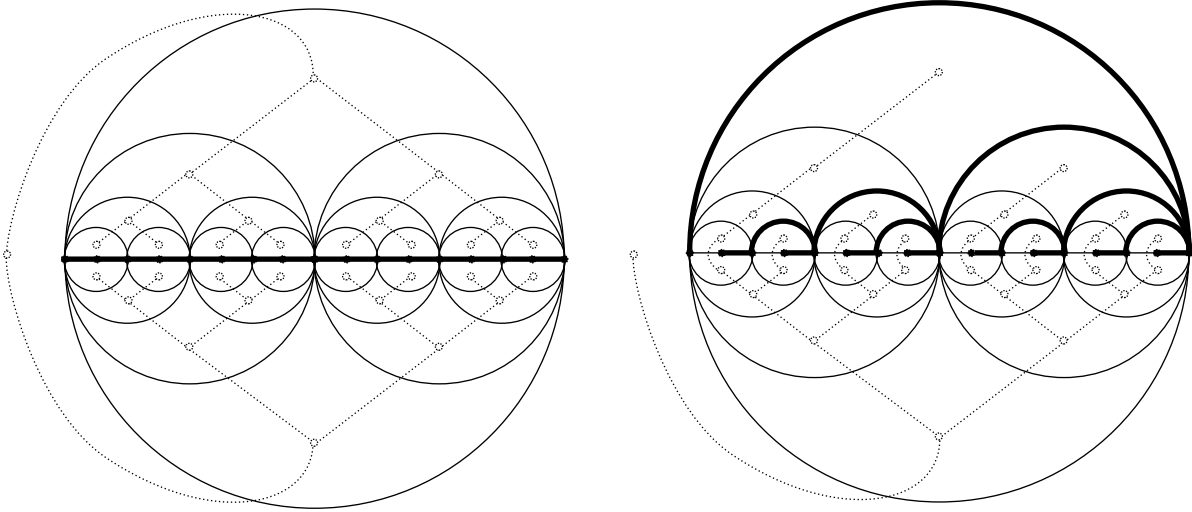

Figure 1: Two complementary pairs of maximal trees for a planar graph G_4 .

The fourth graph of a related family \tilde{G}_n is shown in Figure 2. In \tilde{G}_n each vertex has valence at most 5 and in the dual \tilde{G}_n^* the vertex valences are at most 4. So this family (and their duals) are within the scope of Conjecture 2.3. Like the case of the graphs G_n , taking T^* to be a maximal geodesic tree in \tilde{G}_n^* based at the vertex *at infinity* does not produce a pair of complementary maximal trees that satisfy the requirements of Conjecture 2.3. However taking T to be the maximal tree shown with heavy lines, we get a complementary pair with $\text{Diam}(T) \sim \text{Diam}(T^*) \sim n$.

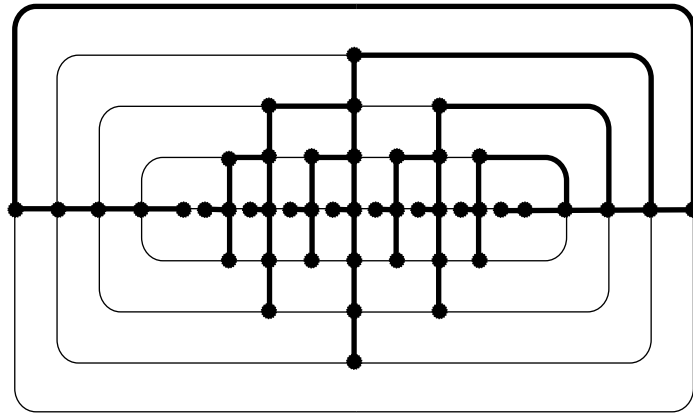

Figure 2: A maximal tree in the diagram \tilde{G}_4 .

An example from a family within the scope of Conjecture 2.4 is shown in Figure 3 in Section 5. These graphs are 1-skeleta of *van Kampen diagrams* (defined in Section 5) for the words $[b^n, a^{-1}][b^n, a]$ over $\langle a, b \mid b^{-1}ab = a^2 \rangle$. All horizontal edges are labelled by a and all vertical edges by b . The left-hand figure shows a choice of maximal trees that gives complementary pairs that fail the conjecture. The right-hand diagram shows a maximal tree T such that $\text{Diam}(T) \sim \text{Diam}(T^*) \sim n$.

4 Singular disc diagrams

Definition 4.1. A *singular disc diagram* $D = S \setminus e_\infty$ is a combinatorial 2-complex that can be obtained from some finite combinatorial 2-complex S homeomorphic to the 2-sphere by removing the interior of a 2-cell e_∞ .

So D is a finite, planar, contractible, combinatorial 2-complex; in general D need not be a topological 2-disc but rather is a tree-like arrangement of

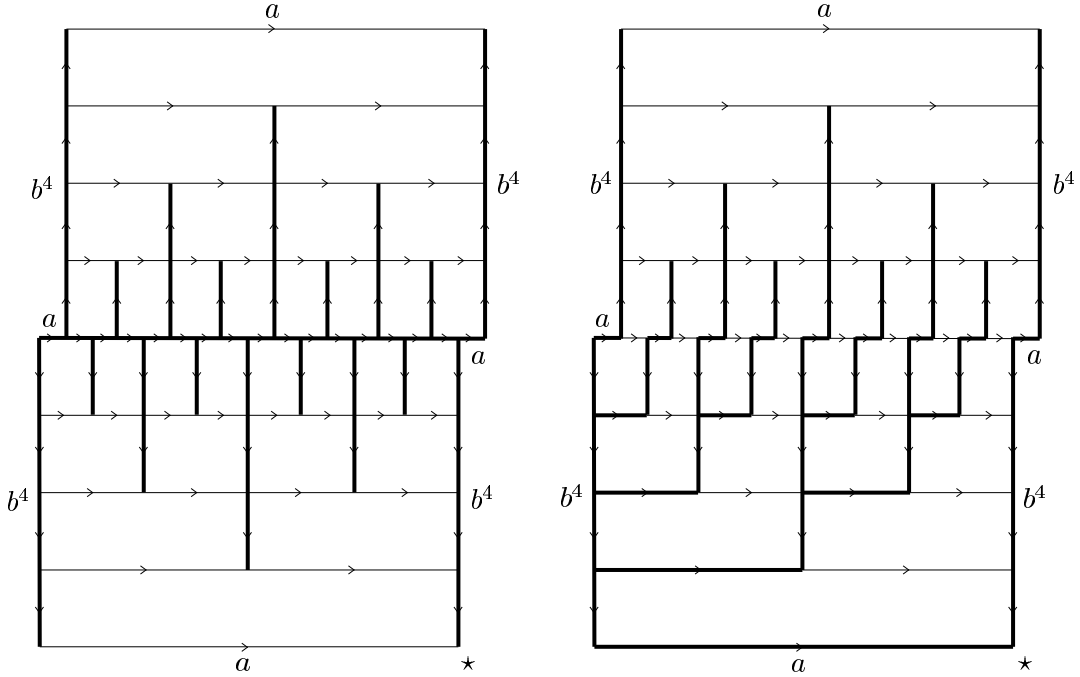

Figure 3: Maximal trees in the 1-skeleton of a van Kampen diagram \hat{D}_4 .

topological discs connected by 1-dimensional arcs. For brevity, we refer to D as a *diagram*.

A finite, connected, undirected graph⁶ G embedded in the 2-sphere induces a combinatorial 2-complex structure S with 1-skeleton G . Associated to S is the dual 2-complex S^* that has a face dual to each vertex of S , an edge dual to each edge of S , and a vertex dual to each face of S . The 1-skeleton of S^* is G^* , the dual graph of G .

Definition 4.2. (Diagram measurements.) A *diagram measurement* M assigns a real number $M(D)$ to a diagram D . We will be concerned with the following diagram measurements.

We define a number of measurements that capture aspects of the geometry of a diagram D with a base vertex v_0 in $\partial D^{(0)}$.

- The *area* $\text{Area}(D)$ is the number of 2-cells in D .

⁶Or “*multigraph*” – see the footnote in Section 1.

- The *diameter* $\text{Diam}(D) := \text{Diam}_{v_0}(G) = \max \{d(v_0, a) \mid a \in G^{(0)}\}$, where $G := D^{(1)}$.
- The *perimeter* $\text{Perimeter}(D)$ is the length of the boundary circuit of D . This equals the valence of the vertex e_∞^* at infinity in G^* .
- The *gallery length* $\text{GL}(D)$ is the diameter of the dual graph G^* , and so is essentially the dual concept to Diam .
- The measurement $\text{DGL}(D)$ is an upper bound for both diameter and gallery length. It is defined to be the minimum of $\text{Diam}(T) + \text{Diam}(T^*)$ as (T, T^*) ranges over all *complementary pairs* of maximal trees for $G = D^{(1)}$.
- $\text{DlogA}(D)$ is defined to be $\text{Diam}(D) + \log_2(\text{Area}(D) + 1)$.
- The *filling length* $\text{FL}(D)$ is the minimum filling length $\text{FL}(\mathcal{S})$ amongst all *shellings* \mathcal{S} of D .

The precise definition of a *shelling* as well as more details about filling length can be found in [11] or [13]. Roughly speaking, a shelling in a *combinatorial null-homotopy* of D down to the base vertex v_0 .

It is a simple consequence of the definitions that Conjecture 2.4 can be reformulated in terms of the diagram measurements $\text{GL}(D)$ and $\text{DGL}(D)$:

Conjecture 4.3. *Fix $\lambda > 0$. There exists $K > 0$ such that if D is a diagram in which every face has boundary circuit of length at most λ , then*

$$\text{GL}(D) \leq \text{DGL}(D) \leq K(\text{GL}(D) + \text{Perimeter}(D)).$$

(The inequality $\text{GL}(D) \leq \text{DGL}(D)$ is not conjectural; it follows immediately from the definitions.)

5 Filling functions for finite presentations

Here we present some of the notions of Geometric Group Theory that we need before we can explain the applications of the conjectures.

Filling functions for a finite presentation $\mathcal{P} = \langle \mathcal{A} \mid \mathcal{R} \rangle$ of a group Γ are defined using measurements of diagrams D_w associated to a proof that a

word⁷ w represents 1 in Γ . So a filling function *captures an aspect of the geometry of the word problem for \mathcal{P}* . The diagrams in question are called *van Kampen diagrams* and we recall their definition below.

Denote the length of w by $\ell(w)$. Let \mathcal{K}^2 be the compact 2-complex with fundamental group Γ associated to \mathcal{P} : to construct \mathcal{K}^2 take a wedge of $|\mathcal{A}|$ circles, label each circle by an element of \mathcal{A} and orient them, and then attach a $\ell(r)$ -sided 2-cell for each $r \in \mathcal{R}$ with r describing its attaching map. Let $C(\mathcal{P}) = \widetilde{\mathcal{K}^2}$ denote the *Cayley 2-complex* associated to \mathcal{P} . The *Cayley graph* of \mathcal{P} is the 1-skeleton of $C(\mathcal{P})$, and the 0-skeleton is identified with Γ so that the combinatorial metric on $C(\mathcal{P})$ agrees with the word metric $d_{\mathcal{P}}$ on Γ . Each edge of the Cayley graph inherits an orientation from \mathcal{K}^2 as well as a label by an element of \mathcal{A} .

A word w in Γ such that $w = 1$ in Γ is said to be *null-homotopic*, or is referred to as an *edge-circuit*, because it defines a loop in $C(\mathcal{P})^{(1)}$ based at 1 (say).

Definition 5.1. Suppose w is a null-homotopic word. Then a diagram $D_w = S \setminus e_{\infty}$ with base vertex v_0 is a *\mathcal{P} -van Kampen diagram*⁸ for w when there is a combinatorial⁹ map $\Phi : (D_w, v_0) \rightarrow (C(\mathcal{P}), 1)$ such that $\Phi|_{\partial D_w}$ is the edge-circuit w .

Each edge of D_w inherits a direction from its image in $C(\mathcal{P})^{(1)}$ and a labelling by an element of \mathcal{A} . So the word one reads around the boundary of each of the 2-cells of D_w is a cyclic conjugate of an element of $\mathcal{R} \cup \mathcal{R}^{-1}$, and starting at the base vertex v_0 one reads w (by convention anticlockwise) around ∂D .

For an edge-circuit w define

$$M(w) := \min \{ M(D_w) \mid D_w \text{ is a van Kampen diagram for } w \},$$

where M is a diagram measurement (see Definition 4.2). We write $M_{\mathcal{P}}(w)$ when we wish to stress the finite presentation concerned.

We mention some equivalent definitions of $\text{Area}(w)$, $\text{Diam}(w)$ and $\text{FL}(w)$. It is a consequence of *van Kampen's lemma* (see [5], [17] or [18]) that $\text{Area}(w)$

⁷Words are strings on letters in \mathcal{A} and their formal inverses, that is, words are the elements of the free monoid $(\mathcal{A} \cup \mathcal{A}^{-1})^*$.

⁸We omit the \mathcal{P} when there is no potential ambiguity.

⁹A *combinatorial* map sends n -cells homeomorphically onto n -cells for all n .

is the least N such that there is an equality

$$w = \prod_{i=1}^N u_i^{-1} r_i u_i \quad (2)$$

in the free group $F(\mathcal{A})$ for some $r_i \in R^{\pm 1}$ and $u_i \in \mathcal{A}^*$. Similarly, up to the additive constant $\max\{\ell(r) \mid r \in R\}$, the diameter $\text{Diam}(w)$ is the minimal bound on the length of the conjugating elements u_i in equalities (2). Proposition 1 in [11] says that $\text{FL}(w)$ is the minimal bound on the length of words one encounters in the process of *applying defining relators*¹⁰ to reduce w to the empty word. There is another interpretation of $\text{Area}(w)$ in this context: it is the number of times relators are *applied* in the course of the reduction. These formulations of the definitions of $\text{Area}(w)$ and $\text{FL}(w)$ are particularly significant because they reveal the resulting filling functions $\text{Area} : \mathbb{N} \rightarrow \mathbb{N}$ and $\text{FL} : \mathbb{N} \rightarrow \mathbb{N}$, defined below, to be the non-deterministic complexity measures of the crude method of attacking the word problem in \mathcal{P} by exhaustively applying relators.

Now we come to the definition of the filling functions.

Definition 5.2. (Filling functions.) For a diagram measurement M we define a filling function $M : \mathbb{N} \rightarrow \mathbb{N}$ for \mathcal{P} by

$$M(n) := \max\{M(w) \mid \text{edge-circuits } w \text{ with } \ell(w) \leq n\}.$$

In particular,

- $\text{Area} : \mathbb{N} \rightarrow \mathbb{N}$ is known as the *Dehn function*,
- $\text{Diam} : \mathbb{N} \rightarrow \mathbb{N}$ is the *minimal isodiametric function*,
- $\text{GL} : \mathbb{N} \rightarrow \mathbb{N}$ is the *gallery length function*, and
- $\text{FL} : \mathbb{N} \rightarrow \mathbb{N}$ is the *filling length function*.

An *isoperimetric* (resp. *isodiametric*) *inequality* for \mathcal{P} is provided by any function $f : \mathbb{N} \rightarrow \mathbb{N}$ such that $\text{Area}(n) \leq f(n)$ (resp. $\text{Diam}(n) \leq f(n)$) for all n .

¹⁰In a presentation $\mathcal{P} = \langle \mathcal{A} \mid \mathcal{R} \rangle$, a word $u\beta v$ is obtained from a word $u\alpha v$ by *applying a defining relator* when a cyclic conjugate of the word $\alpha^{-1}\beta$ is in $\mathcal{R}^{\pm 1}$.

There are many references to isoperimetric functions, Dehn functions and isodiametric functions in the literature; [5] and [8] are surveys. The filling length function is discussed extensively in [11] and has an important application in [10]. We introduced GL and DGL in [13], and DlogA, which will play an important role in Section 7, is new.

The word problem for \mathcal{P} is solvable if and only if any one (and hence all – see Section 9) of the filling functions Area, GL, DGL, DlogA and FL is bounded above by a recursive function – see [8].

The following equivalence relation on functions $\mathbb{N} \rightarrow \mathbb{N}$ is well-known.

Definition 5.3. (\simeq -equivalence.) For two functions $f, g : \mathbb{N} \rightarrow \mathbb{N}$ we say that $f \preceq g$ when there exists $C > 0$ such that $f(n) \leq Cg(Cn + C) + Cn + C$ for all n , and we say $f \simeq g$ if and only if $f \preceq g$ and $g \preceq f$.

For example, for $p, q \geq 1$ we have $n^p \simeq n^q$ if and only if $p = q$.

Recall that Conjecture 2.4 about planar graphs was reformulated in terms of diagram measurements GL and DGL in Conjecture 4.3. Conjecture 4.3 is true then so is the following.

Conjecture 5.4. *The filling functions $GL_{\mathcal{P}}$ and $DGL_{\mathcal{P}}$ for any given finite group presentation \mathcal{P} are \simeq -equivalent.*

It is important to note that the filling functions are defined for specific finite presentations for groups. However, up to \simeq -equivalence, Area and FL depend only on the group. Indeed both are quasi-isometry invariants up to \simeq -equivalence – see [1] and Theorem 8.1 of this article. The situation for GL is a little more complicated. One needs the following notion of *fattening* a presentation $\mathcal{P} = \langle \mathcal{A} \mid \mathcal{R} \rangle$ by adding to \mathcal{A} an extra generator z which represents 1 in the group, and adding a number of extra relations involving z to \mathcal{R} .

Definition 5.5. (Fat presentations.) One obtains a *fat* presentation \mathcal{P}' from a presentation $\mathcal{P} = \langle \mathcal{A} \mid \mathcal{R} \rangle$ by adjoining an extra generator z to \mathcal{A} as follows:

$$\mathcal{P}' := \langle \mathcal{A} \cup \{z\} \mid \mathcal{R} \cup \{z, z^2, zz^{-1}, z^3, z^2z^{-1}\} \cup \{[a, z] : a \in \mathcal{A} \cup \{z\}\} \rangle.$$

It is proved in [13] that if \mathcal{P} and \mathcal{Q} are two finite presentations for the same group Γ then the gallery length functions $\text{GL}_{\mathcal{P}'}$ and $\text{GL}_{\mathcal{Q}'}$ of the fat presentations \mathcal{P}' and \mathcal{Q}' are \simeq -equivalent. This result is shown in Theorem 8.1 of this article to continue to hold under the weaker hypothesis that \mathcal{P} and \mathcal{Q} present quasi-isometric groups.

In our study of central extensions, we will need to monitor not only how the gallery length functions of two finite presentations of the same groups are related, but also how *simultaneous* area and gallery length bounds change. The following definition gives us the appropriate notation and the subsequent proposition, which is [13, Scholium 4.7], gives us the control we will require.

Definition 5.6. We say that a pair (f, g) of functions $f, g : \mathbb{N} \rightarrow \mathbb{N}$ is an (Area, GL) -pair for the finite presentation \mathcal{P} when, for every edge-circuit w in the Cayley graph of \mathcal{P} , there exists a van Kampen diagram D_w with $\text{Area}(D_w) \leq f(\ell(w))$ and $\text{GL}(D_w) \leq g(\ell(w))$.

Proposition 5.7. *Suppose that \mathcal{P} and \mathcal{Q} are two finite presentations for the same group Γ , and that \mathcal{P}' and \mathcal{Q}' are their fattenings. If $(f_{\mathcal{P}'}, g_{\mathcal{P}'})$ is an (Area, GL) -pair for \mathcal{P}' then there is an (Area, GL) -pair $(f_{\mathcal{Q}'}, g_{\mathcal{Q}'})$ for \mathcal{Q}' such that $f_{\mathcal{P}'} \simeq f_{\mathcal{Q}'}$ and $g_{\mathcal{P}'} \simeq g_{\mathcal{Q}'}$.*

6 The geometry of central extensions

We begin an examination of the geometry of central extensions $\hat{\Gamma}$ of finitely presentable groups Γ with the case where the central abelian kernel is \mathbb{Z} :

$$1 \rightarrow \mathbb{Z} \rightarrow \hat{\Gamma} \rightarrow \Gamma \rightarrow 1.$$

If $\mathcal{P} = \langle \mathcal{A} \mid \mathcal{R} \rangle$ is a presentation for Γ then there is a presentation for $\hat{\Gamma}$ of the form

$$\hat{\mathcal{P}} = \langle \hat{\mathcal{A}} \mid \hat{\mathcal{R}} \rangle = \langle \mathcal{A} \cup \{z\} \mid r = z^{n_r} \text{ for } r \in \mathcal{R}; [z, a] \text{ for all } a \in \mathcal{A} \rangle.$$

Define $M := \max \{|n_r| \mid r \in \mathcal{R}\}$.

Proposition 6.1. (Infinite cyclic kernel case.) *Suppose w is a word in $(\mathcal{A}^{\pm 1})^*$ that represents 1 in Γ , and so represents z^m in $\hat{\Gamma}$ for some integer m . Assume D is a \mathcal{P} -van Kampen diagram for an edge-circuit w . Let T be a maximal tree in $G = D^{(1)}$. As usual, the base vertex of D is called v_0 .*

There is a $\hat{\mathcal{P}}$ -van Kampen diagram \hat{D} for wz^{-m} such that

$$\text{Diam}(\hat{G}^*) \leq 2 \text{Diam}_{v_0}(T) + \text{Diam}(T^*), \quad (3)$$

$$\text{Area}(\hat{D}) \leq M \text{Diam}_{v_0}(T) \text{Area}(D) + \text{Area}(D), \quad (4)$$

where \hat{G}^* is the graph dual to $\hat{G} = \hat{D}^{(1)}$.

Proof. We will *inflate* D to produce a $\hat{\mathcal{P}}$ -van Kampen diagram \hat{D} for wz^{-m} . The defining relators r in \mathcal{R} are expanded to relators rz^{-nr} in $\hat{\mathcal{R}}$ and the resulting introduction of the z -edges in the boundaries of the corresponding 2-cells prevent them fitting together in the same arrangement as in D to make a $\hat{\mathcal{P}}$ -van Kampen diagram. The remedy is to use the *electrostatic model* as explained in the following three steps and illustrated in Figures 4 and 5.

1. *Charge the diagram D .*

Fix an embedding of D in the plane. Each 2-cell e in D has its boundary labelled by some $r \in \mathcal{R}^{\pm 1}$ read from a base vertex $v_e \in \partial e$. Inscribe a planar wedge of $|n_r|$ 2-discs in e ; each of these 2-discs has boundary made up of one directed 1-cell whose initial and terminal vertices are both identified with v_e . Refer to each of these 2-discs as *charges*; each has boundary loop labelled by z and is directed in such a way that around the boundary loop of the (now altered) 2-cell e one reads the relator $(rz^{-nr})^{\pm 1}$. We say that a charge is *positive* or *negative* depending on whether one reads z in a clockwise or anticlockwise direction. Call the charged diagram D^c .

The left-hand diagram of Figure 6 is an example of a charged diagram. Here charges are inserted to inflate the relators $[x, y]$ to $[x, y]z^{-1}$.

2. *Discharge along the maximal tree T .*

To get a van Kampen diagram for w from D^c a natural approach is to *blow up* each vertex and then to *fold* together edges labelled z . However for this to work it is necessary that the charge at each vertex v is *electrostatically neutral* – that is, there are the same number of positive charges as negative charges attached to v . The way we achieve this is to *discharge the diagram along T* . At each vertex pair off the positive charges with the negative charges and refer to the remaining unpaired charges as the *excess charges*. We now *discharge* the excess charge to v_0 as follows. We transfer all the excess charge at each vertex v in D^c along a path p in T to v_0 using a *string of digons*. Each 1-cell in p is doubled to create a digon (one of the two resulting edges is chosen to be in the maximal tree of the new diagram), and then a positive

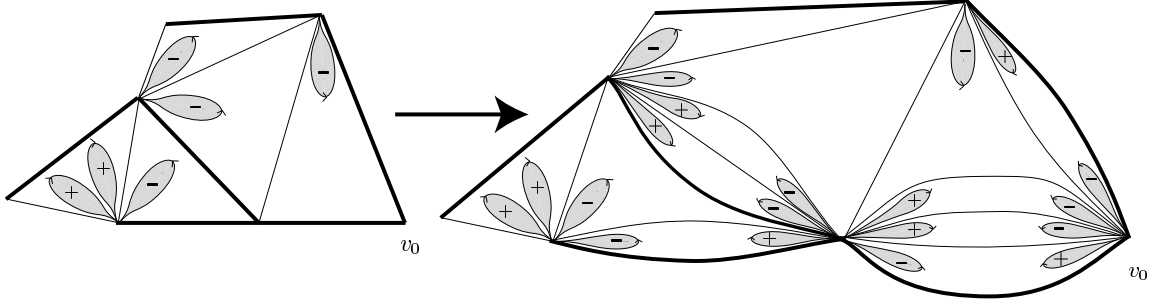

Figure 4: Discharge of excess charge along a maximal tree T in a van Kampen diagram to v_0 .

charge is added at one end of the digon and a negative charge at the other. The charged digons are aligned along p in such a way that at every vertex on p apart from v and v_0 , one positive charge and one negative charge is added. The effect is then that the net charge at v is altered by one at the expense of the charge at v_0 . The net charge at each of the other vertices is left unchanged.

3. Blow-up and fold.

From a diagram where all vertices apart from v_0 are electrically neutral, we produce a diagram over the presentation $\hat{\mathcal{P}}$, that is, a diagram in which all the 2-cells have boundaries labelled by words in $\hat{\mathcal{R}}^{\pm 1}$. The wedge of 2-disc charges at each vertex $v \neq v_0$ is *blown up* into a 2-cell with boundary word made up of z and z^{-1} 's. The exponent sum of the $z^{\pm 1}$'s comprising this word is zero as the net charge at v is neutral. Adjacent $z z^{-1}$ or $z^{-1} z$ pairs are then *folded* together until the blown-up 2-cell is entirely eliminated. (This process of folding does not need to be specified uniquely.)

The *blow-up* procedure at v_0 differs in that we cut out the charges at v_0 so as to introduce a subword u made up of z and z^{-1} 's into the diagram's boundary word. So the boundary word of the new diagram is uw . But then $u = z^{-m}$ in $\hat{\Gamma}$ because $w = z^m$ in $\hat{\Gamma}$. Thus the exponent sum of the letters z comprising u is $-m$ and folding together adjacent $z z^{-1}$ or $z^{-1} z$ pairs in u gives a diagram \hat{D} with boundary circuit $z^{-m'} w$ for some m' . And because $w = z^{m'} = z^m$ we have $m = m'$.

The 3-dimensional integral Heisenberg group $\langle x, y, z \mid [x, y] = z, [x, z] = 1, [y, z] = 1 \rangle$ is an example of a central extension with kernel $\mathbb{Z} = \langle z \rangle$. The effect of charging a diagram for the word $[x^{-3}, y^{-3}][y^3, x^3]$ over $\langle x, y \mid [x, y] \rangle$,

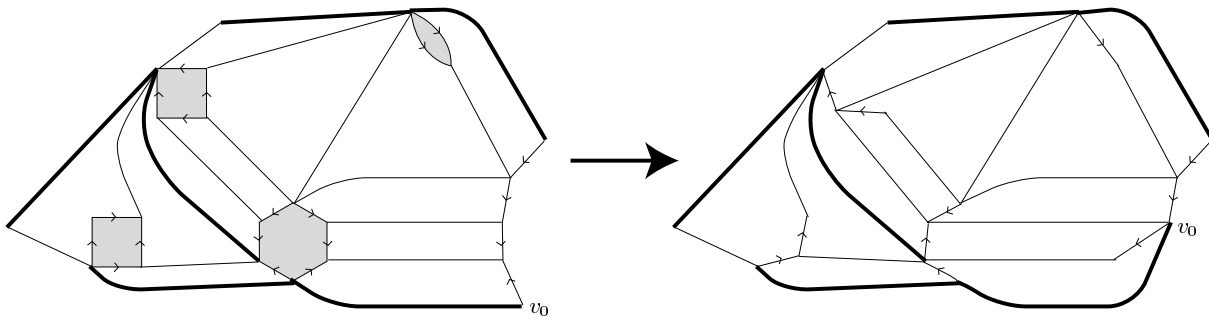

Figure 5: The effect of blowing up and then folding the diagram from Figure 4.

discharging along a maximal tree T (depicted using heavier lines), blowing-up and then folding is illustrated in Figure 6. In this case each relator $[x, y]$ is inflated to include one z -edge and the discharge procedure collects nine positive charges and nine negative charges at v_0 . Blowing up at v_0 inserts a subword $z^9 z^{-9}$ into the boundary word, which is then folded into the interior of the final diagram.

We now prove the bounds (3) and (4) for \hat{D} . A copy of the maximal tree T^* in G^* can be found in \hat{G}^* , and this can be reached from any vertex in G^* by following a path along one of the z -corridors. These z -corridors have length at most $\text{Diam}_{v_0}(T)$, hence the bound (3). For the area bound (4), let $Q(D^c)$ denote the total charge $\sum_e |n_{r_e}|$, summed over the $\text{Area}(D)$ 2-cells e of the D , where r_e is the relator that is the boundary word for e . Then $Q(\overline{D}) \leq M \text{Area}(D)$ is an upper bound for the total number of z -corridors introduced into D when making \hat{D} . Each of these corridors is made up of at most $\text{Diam}_{v_0}(T)$ 2-cells. So the first term on the right-hand-side of (4) is an upper bound on the total contributions made by the z -corridors to the area of \hat{D} . The remainder of \hat{D} is the inflated $\text{Area}(D)$ 2-cells from D , and thus we deduce (4). \blacksquare

The methods above can be adapted to the case where the central abelian kernel is a finite cyclic group C_q :

$$1 \rightarrow C_q \rightarrow \hat{\Gamma} \rightarrow \Gamma \rightarrow 1.$$

If $\mathcal{P} = \langle \mathcal{A} \mid \mathcal{R} \rangle$ is a presentation for Γ then there is a presentation for $\hat{\Gamma}$ of the form

$$\hat{\mathcal{P}} = \langle \hat{\mathcal{A}} \mid \hat{\mathcal{R}} \rangle = \langle \mathcal{A} \cup \{z\} \mid r = z^{n_r} \text{ for } r \in \mathcal{R}; [z, a] \text{ for all } a \in \mathcal{A}; z^q \rangle.$$

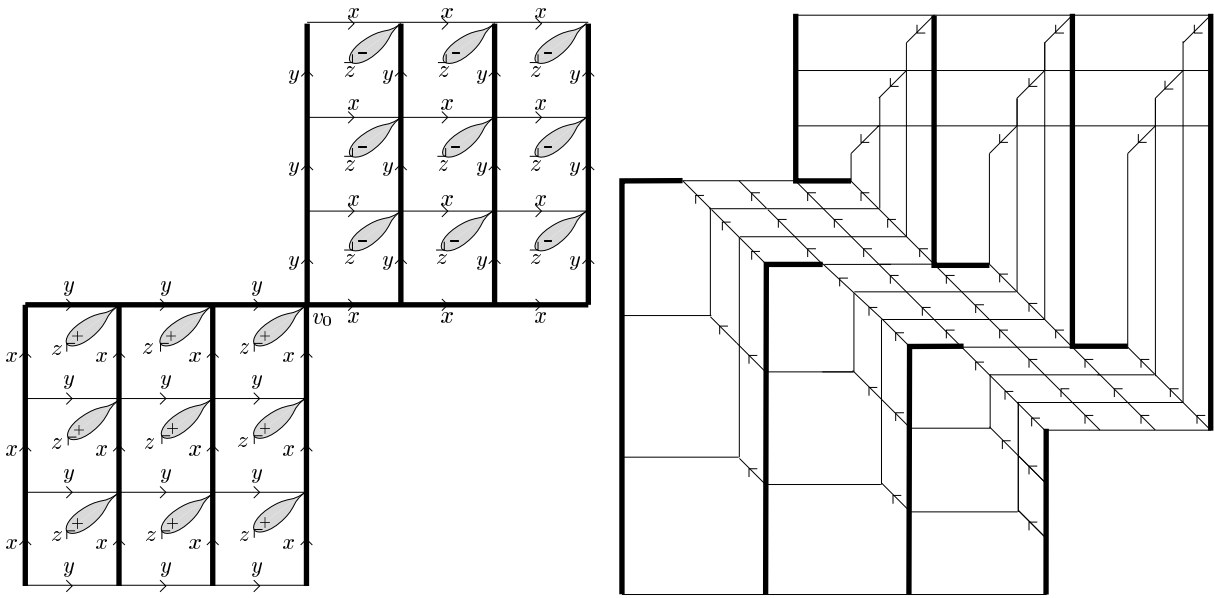

Figure 6: A van Kampen diagram for the word $[x^{-3}, y^{-3}][y^3, x^3]$ over $\langle x, y \mid [x, y] \rangle$ *charged* and then *inflated* to a diagram over the 3-dimensional integral Heisenberg group $\langle x, y, z \mid [x, y] = z, [x, z] = 1, [y, z] = 1 \rangle$. In the right-hand diagram the edges whose directions have been marked are the z -edges.

We can assume that $0 \leq n_r < q$ for all $r \in \mathcal{R}$. The conclusion of the following proposition differs from that of Proposition 6.1 in the bound on the area of \hat{D} .

Proposition 6.2. (*Finite cyclic kernel case.*) *Suppose w is a word in $(\mathcal{A}^{\pm 1})^*$ that represents 1 in Γ , and so represents z^m in $\hat{\Gamma}$ for some non-negative integer $m < q$. Assume that D is a \mathcal{P} -van Kampen diagram for an edge-circuit w . Let T be a maximal tree in $G = D^{(1)}$. Let $C := \max \{\ell(r) \mid r \in \mathcal{R}\}$.*

There is a $\hat{\mathcal{P}}$ -van Kampen diagram \hat{D} for wz^{-m} such that

$$\text{Diam}(\hat{G}^*) \leq 2 \text{Diam}_{v_0}(T) + \text{Diam}(T^*), \quad (5)$$

$$\text{Area}(\hat{D}) \leq 2 \text{Area}(D) + (q-1)(C \text{Area}(D) + \ell(w)), \quad (6)$$

where \hat{G}^* is the dual graph to $\hat{G} = \hat{D}^{(1)}$.

Proof. We adapt the *electrostatic model* of the proof of Proposition 6.1 as follows. We *charge the diagram* (this time all the charges are positive because $0 \leq n_r < q$ for all $r \in \mathcal{R}$) and then *discharge to v_0 along the maximal tree T* as before. But then before *blowing-up and folding* the diagram we *remove digons* as follows. Let v , if it exists, be an edge a maximal distance from v_0 in T such that there are at least q digons along the first edge e on the geodesic γ in T from v to v_0 . Then there are at least q digons along every edge of γ . We remove q digons from each edge of γ . Perform this removal of digons repeatedly until no v can be found. In this way arrive at a diagram in which the number of digons along each edge is no more than $q-1$, and the net charge at each vertex is $0 \pmod q$. We then produce the diagram \hat{D} by *blowing up and folding* as before, except that this time if a vertex $v \neq v_0$ has total charge kq then k faces labelled z^{-q} will be inserted into the diagram. A word z^l will be inserted into the boundary of the diagram at v_0 with $l = m \pmod q$, and we reduce this to z^m by attaching k faces labelled z^{-q} where $l = kq + m$. The result is a diagram \hat{D} for wz^{-1} .

The inequality (5) on $\text{Diam}(\hat{G}^*)$ is proved in the same way as (3). The area bound (6) arises from considering the following three contributions to faces in \hat{D} – the $\text{Area}(D)$ faces in D are inflated to faces in \hat{D} ; each edge in T , of which there are at most $C \text{Area}(D) + \ell(w)$, is *fattened* to no more than $(q-1)$ digons before the *blowing-up and folding* procedure, and each of these digons gives a face in \hat{D} with boundary label $[a, z]^{\pm 1}$ for some $a \in \mathcal{A}$; and the number of z^{-q} faces in \hat{D} is at most $\text{Area}(D)$ because at most $(q-1) \text{Area}(D)$ z -edges are introduced when D is charged. ■

The propositions above allow us to formulate results that give restrictions on how the geometry of the word problem of a group can change when one moves to a central extension. These results are framed in terms of “(Area, GL)-pairs” (see Definition 5.6) and the related notion of “(Area, DGL)-pairs” which are identically defined except with the filling function DGL (defined in Section 5) replacing GL.

Theorem 6.3. *Suppose that $1 \rightarrow \Lambda \rightarrow \hat{\Gamma} \rightarrow \Gamma \rightarrow 1$ is a central extension of the finitely presented group Γ , and that (f, g) is an (Area, DGL)-pair for a finite presentation \mathcal{P} of Γ .*

- *If $\Lambda = \mathbb{Z}$ then, up to a common multiplicative constant, $(f(n)g(n) + n^2, g(n) + n)$ is an (Area, GL)-pair for the finite presentation $\hat{\mathcal{P}}$ of Proposition 6.1 for $\hat{\Gamma}$.*
- *If $\Lambda = C_q$, a finite cyclic group of order q , then, up to a common multiplicative constant, $(f(n) + n, g(n) + n)$ is an (Area, GL)-pair for the finite presentation $\hat{\mathcal{P}}$ of Proposition 6.2 for $\hat{\Gamma}$.*

Proof. Suppose \hat{w} is a word in $(\hat{\mathcal{A}}^{\pm 1})^*$ that represents 1 in the group $\hat{\Gamma}$ presented by $\hat{\mathcal{P}} = \langle \hat{\mathcal{A}} \mid \hat{\mathcal{R}} \rangle$. Let $n := \ell(\hat{w})$ and let w be the word obtained from \hat{w} by removing all instances of the generator z of the cyclic central kernel Λ . Then w represents 1 in Γ and z^m in $\hat{\Gamma}$ for some integer m (with $0 \leq m < q$ in the case of $\Lambda = C_q$). Let D be a \mathcal{P} -van Kampen diagram for w exhibiting the Area and DGL bounds on the (Area, DGL)-pair for \mathcal{P} . Let \hat{D} be the $\hat{\mathcal{P}}$ -van Kampen diagram for wz^{-m} of Proposition 6.1 in the case of $\Lambda = \mathbb{Z}$ and of Proposition 6.2 in the case of $\Lambda = C_q$.

We attach a planar *annular* diagram A around the boundary of \hat{D} to affect a transformation of \hat{w} to wz^{-m} and thereby produce a van Kampen diagram for \hat{w} as follows.

In the case $\Lambda = \mathbb{Z}$, the exponent sum of the occurrences of z in w equals m , and A consists of z -corridors that collect the letters $z^{\pm 1}$ in \hat{w} together so that after cancelling zz^{-1} pairs we have wz^{-m} . The length of each z -corridor is at most n and so the increase in gallery length when A is attached to \hat{D} is at most $2n$. The area of A is at most n^2 since each letter z is moved a distance at most n using commutator relations.

When $\Lambda = C_q$, the exponent sum of the occurrences of z in w equals $m \bmod q$. We let A be the annular diagram with outer boundary \hat{w} and inner boundary wz^{-m} that is obtained by moving letters z around \hat{w} using

commutator relations as follows. We start at the left-hand end of the word w and read along the word from left to right. Each time we come to a letter $z^{\pm 1}$ we move it to the right until we either come to a $z^{\mp 1}$, in which case we cancel the two letters, or we come to a $z^{\pm 1}$, in which case we carry this letter along also. As we progress through the word we pick up more and more letters $z^{\pm 1}$ in this way, and if the number of letters we are carrying reaches $\pm q$ we apply the relator $z^q = 1$ to cancel them all. When we reach the right-hand end of the word we have transformed the word to wz^{-m} or wz^{-m+q} . In the latter case we use a relator $z^q = 1$ to get the word wz^{-m} .

The total number of $z^q = 1$ relations we use is at most $1 + (n/q)$ and at any stage in the above process we are moving at most $q - 1$ letters $z^{\pm 1}$ through the word, so we use at most $(q - 1)n$ commutator relations. Thus the area of A is at most n , up to a multiplicative constant. It follows that attaching A to \hat{D} does not increase the gallery length by more than n , up to a multiplicative constant. ■

Recall that Conjecture 4.3 claims a close relationship between the diagram measurements GL and DGL.

Corollary 6.4. *Assuming Conjecture 4.3 holds, Theorem 6.3 is true under the weaker hypothesis that (f, g) is a (Area, GL)-pair.*

Having considered the cases of a central extension with kernel \mathbb{Z} or C_q , one is ready for the general case of a central extension with kernel an arbitrary finitely generated abelian group Λ .

Theorem 6.5. *Assume Conjecture 4.3 holds. Let*

$$1 \rightarrow \Lambda \rightarrow \hat{\Gamma} \rightarrow \Gamma \rightarrow 1$$

be a central extension of the finitely presented group Γ with finitely generated abelian kernel Λ . Let $\mathcal{P} = \langle \mathcal{A} \mid \mathcal{R} \rangle$ be a finite presentation for Γ and let (f, g) be an (Area, GL)-pair for \mathcal{P} . Then there is a finite presentation $\hat{\mathcal{P}}$ for $\hat{\Gamma}$ such that, up to a common multiplicative constant, $(f(n)g(n) + n^2, g(n) + n)$ is an (Area, GL)-pair for $\hat{\mathcal{P}}$.

Proof. We express Λ as a direct product $\mathbb{Z}^k \times C_{q_1} \times C_{q_2} \times \cdots \times C_{q_j}$ of cyclic groups and choose a basis z_1, z_2, \dots, z_k for the factor \mathbb{Z}^k , and generators z_{k+i} for the C_{q_i} for $i = 1, 2, \dots, j$.

Take the presentation $\hat{\mathcal{P}}$ for $\hat{\Gamma}$ to be $\langle \hat{\mathcal{A}} \mid \hat{\mathcal{R}} \rangle$ where $\hat{\mathcal{A}} = \mathcal{A} \cup \{z_i \mid 1 \leq i \leq j+k\}$ and $\hat{\mathcal{R}}$ is

$$\begin{aligned} & \{ r = u_r \mid r \in \mathcal{R} \} \\ & \cup \{ [a, z_i] \mid a \in \mathcal{A}, 1 \leq i \leq j+k \} \\ & \cup \{ [z_i, z_{i'}] \mid 1 \leq i, i' \leq j+k \} \\ & \cup \{ z_{k+i}^{q_i} \mid 1 \leq i \leq j \}, \end{aligned}$$

with u_r a word in the generators z_1, z_2, \dots, z_{k+j} . Suppose \hat{w} is a word in the generators of $\hat{\mathcal{P}}$ such that $\hat{w} = 1$ in $\hat{\Gamma}$, and let w be obtained from \hat{w} by deleting all letters $z_i^{\pm 1}$ for all i . Then $w = 1$ in Γ .

Choose a \mathcal{P} -van Kampen diagram D for w according to the (Area, GL)-pair for \mathcal{P} .

We construct intermediate central extensions by adding one central basis element z_i at a time: that is we pass from $\hat{\Gamma} / \langle z_1, z_2, \dots, z_i \rangle$ to $\hat{\Gamma} / \langle z_1, z_2, \dots, z_{i-1} \rangle$. On adding each z_i we *inflate* the van Kampen diagram as per Corollary 6.4 to produce a van Kampen diagram for a word in which letters $z_j^{\pm 1}$ are returned to their places in \hat{w} .

Inductively we see that the gallery length of the diagrams remains bounded by $g(\ell(\hat{w})) + n$ up to a multiplicative constant. However the bound we get on the area of these diagrams from Corollary 6.4 increases by a factor of the gallery length with each successive central extension. But, looking back at (4) we see that the dominant term in the area estimate is the product term $\text{Diam}_{v_0}(T) \text{Area}(D)$ that comes from the contributions of the corridors that move central elements (“charges”) along the tree T when we *blow up* relators from \mathcal{R} .

The total amount of *charge* moved throughout the $j+k$ successive central extensions is at most $M \text{Area}(\overline{D})$, where M is the maximum length of the words u_r . The diameter of the trees T (and hence the length of the resulting corridors) remains bounded in terms of $g(\ell(\hat{w}))$. So the area of the final $\hat{\mathcal{P}}$ -van Kampen diagram is controlled by $f(\ell(w))g(\ell(w))$. ■

Recall that a group Γ is nilpotent of class c when the lower series is a central series, defined inductively by $\Gamma_1 := \Gamma$ and $\Gamma_{i+1} := [\Gamma_i, \Gamma]$, terminates at $\Gamma_{c+1} = \{1\}$:

$$\Gamma = \Gamma_1 \supseteq \Gamma_2 \supseteq \dots \supseteq \Gamma_{c+1} = \{1\}.$$

For each i , the group Γ_i is a central extension of Γ_{i+1} , and the presentation $\langle x \mid x \rangle$ of the trivial group admits the (Area, GL)-pair $(n, 2)$. So repeated

application of Corollary 6.4 starting at the trivial group, together with Proposition 5.7, gives:

Corollary 6.6. *Assume Conjecture 4.3 holds. If \mathcal{P} is a finite fat presentation for a finitely generated nilpotent group Γ of class c then, up to a common multiplicative constant, (n^{c+1}, n) is an (Area, GL)-pair for \mathcal{P} .*

The isoperimetric function n^{c+1} (up to a multiplicative constant) would reproduce the result of [10], [14], [15]. If Conjecture 4.3 holds then by Theorem 1.2 the linear bound on the gallery length would also recapture the linear bound on filling length of [10], [20].

7 Controlling gallery length using DlogA

The main result of this section is Theorem 7.1 in which we give a convenient method of controlling the gallery length filling function. We prove that for a null-homotopic word w in a *fat* finite presentation (see Definition 5.5), the sum of upper bounds for the diameter and the logarithm of the area, realisable simultaneously on one van Kampen diagram for w , can be used to estimate $\text{GL}(w)$.

The theorem will be useful in Section 8 in which we give upper bounds on the gallery length of a number of different classes of groups. Also the results and constructions in this section contribute to the theory of how filling functions interrelate (see Section 9) and to understanding *restricted filling functions* (which we introduce in Section 10).

We use the filling function $\text{DlogA} : \mathbb{N} \rightarrow \mathbb{N}$ that arises from the diagram measurement:

$$\text{DlogA}(D) := \text{Diam}(D) + \log_2(\text{Area}(D) + 1).$$

(See Definitions 4.2 and 5.2.)

Theorem 7.1. *If \mathcal{P} is a fat finite presentation then its filling functions GL and DlogA satisfy $\text{GL} \simeq \text{DlogA}$.*

We set out the construction used in proving the bound $\text{GL} \preceq \text{DlogA}$ in the following proposition. (Conclusion (iii) is not used in the proof of Theorem 7.1 but will be used to establish Proposition 7.5 and (C) of Theorem 10.3.)

Proposition 7.2. *Suppose \mathcal{P} is a fat finite presentation for a group Γ .*

There exists a constant $M > 0$, depending only on \mathcal{P} , that satisfies the following. Suppose that D is a \mathcal{P} -van Kampen diagram for an edge-circuit w and that T is a maximal tree in $D^{(1)}$. There is a \mathcal{P} -van Kampen diagram \tilde{D} for w in which every vertex has valence at most 12 and there is a maximal tree \tilde{T} in $\tilde{D}^{(1)}$ such that

- (i). $\text{Area}(\tilde{D}) \leq M \text{Area}(D) (1 + \text{Diam}(T))$,
- (ii). $\text{Diam}(\tilde{T}) \leq M (1 + \text{Diam}(T) + \log_2(\text{Area}(D) + 1))$,
- (iii). $\text{Diam}(\tilde{T}^*) \leq M (\text{Diam}(T) + \text{Diam}(T^*) + n)$,

where $n := \ell(w)$.

Proof. As \mathcal{P} is fat, \mathcal{A} includes some letter z such that the words $z, z^2, zz^{-1}, z^3, z^2z^{-1}$ and $[a, z]$ for all $a \in \mathcal{A} \cup \{z\}$ are in \mathcal{R} . It will be convenient to have some further defining relators at our disposal for the construction of \tilde{D} . For a word $r = a_1a_2 \dots a_p$ define $\tilde{r} := a_1za_2z \dots a_pz$. Then let $\tilde{\mathcal{P}} := \langle \tilde{\mathcal{A}} \mid \tilde{\mathcal{R}} \rangle$ where $\tilde{\mathcal{A}} := \mathcal{A}$ and $\tilde{\mathcal{R}}$ is defined to be the union of \mathcal{R} with the set of words in $\{z, z^{-1}\}^*$ of length four or five and with $\{\tilde{r} \mid r \in \mathcal{R}^{\pm 1}\}$.

In what follows we show that there is a $\tilde{\mathcal{P}}$ -van Kampen diagram \tilde{D} for w with the properties listed above save that the valence bound is 6 rather than 12. Then we will show that the use of these extra relations can be circumvented and \tilde{D} can be converted into a \mathcal{P} -van Kampen diagram for w with the valence bound increasing to no more than 12, and without destroying the bounds (i), (ii) and (iii).

Define $C := \max \{ \ell(r) \mid r \in \tilde{\mathcal{R}} \}$, the length of the longest of the defining relators for $\tilde{\mathcal{P}}$.

We explain a four-step process of obtaining a $\tilde{\mathcal{P}}$ -van Kampen diagram \tilde{D} for w from D . In the first three steps we invoke the methods of the *electrostatic model* of Section 6.

1. *Charge the diagram D .*

We *charge* every 2-cell e of D as follows. We inscribe one 2-cell e_v (called a *charge*) into e at each vertex v on ∂e . The boundary of e_v is a single edge and its initial and terminal vertices are both identified with v . It is directed clockwise¹¹ and is labelled by z .

¹¹We mean clockwise with respect to a fixed orientation of the plane and a fixed embedding of D in the plane.

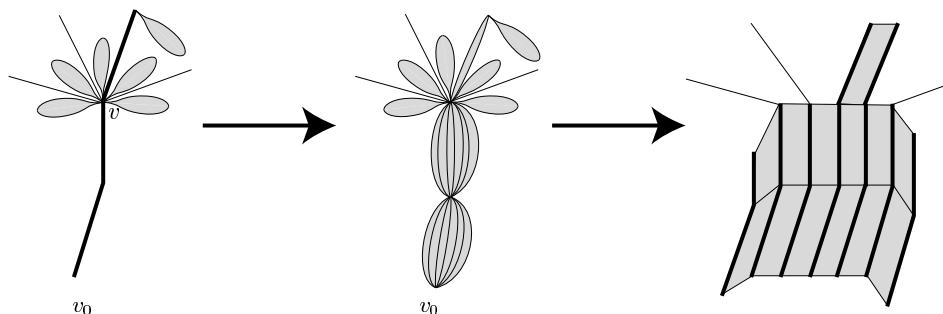

Figure 7: The effect of charging at a vertex v , then discharging along a maximal tree, and then blowing-up.

2. *Discharge along the maximal tree T .*

Transfer every charge to v_0 along a *string of digons* as described in Section 6.

3. *Blow-up the diagram.*

Inflate the charges so as to produce a labelled diagram D' . The inflation introduces a z -edge at each vertex of the boundary circuit of each of the 2-cells in D , changing the boundary word of each 2-cell (read anticlockwise from some vertex) from some $r \in \mathcal{R}^{\pm 1}$ to \tilde{r} . Furthermore, the *strings of digons* inflate to give z -corridors along the course of geodesics in T towards v_0 . The effect at v_0 is to insert an extra edge path τ into the boundary circuit, so that one reads z^m along τ . Thus the boundary word is extended from w to wz^{-m} and D' is a $\tilde{\mathcal{P}}$ -van Kampen diagram for wz^{-m} .

Notice that m is the total number of *charges* inserted into D in step 1 and

$$m \leq C \text{Area}(D) \tag{7}$$

because at most C *charges* are inserted into each 2-cell of D .

Figure 7 illustrates the effect of *charging* a vertex v in the interior of D , then *discharging* along a geodesic in T , and then *blowing-up*. The five charges arranged around v result in five z -edges being inserted into the boundary of the diagram at v_0 . A charge at a vertex *beyond* v in T is also shown, and this contributes a sixth z -edge to the boundary of the diagram.

4. *Attach a van Kampen diagram B_{-m} reducing z^m to the empty word.*

This step involves $\tilde{\mathcal{P}}$ -van Kampen diagrams B_{-m} for words z^{-m} whose construction we now explain. If $m \leq 5$ then B_{-m} is one 2-cell with $\ell(u)$

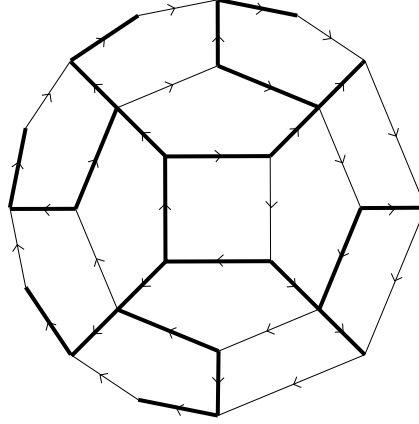

Figure 8: The $\tilde{\mathcal{P}}$ -van Kampen diagram B_{-13} . All edge-labels are z .

directed boundary edges labelled in such a way that the boundary word is z^{-m} . Assume $m > 5$. Let k be the least integer such that $m \leq 2^k$. The diagram B_{-m} has $k - 2$ concentric *annular z -corridors*, arranged around a four-sided 2-cell. All the 2-cells in the annuli are five-sided with the exception of $2^k - m$ in the outermost ring which are four-sided. All the edges in B_{-m} are labelled by z . The boundary edges are directed in such a way that one reads u anticlockwise around the boundary (from some starting vertex). The directions of the interior edges are chosen arbitrarily.

Figure 8 illustrates $A_{z^{-13}}$. Notice that three cells in the outermost annulus are four-sided on account of $k = 4$ and $2^k - 13 = 3$.

We note that B_{-m} is a van Kampen diagram over $\tilde{\mathcal{P}}$ and $\text{Area}(B_{-m}) \leq m$. Attach B_{-m} to D' along τ . The result is a $\tilde{\mathcal{P}}$ -van Kampen diagram \tilde{D} for w .

Now we examine the geometry of \tilde{D} and prove the upper bound of 6 on the valence of its vertices. The valence of every vertex v in the interior of D' after blowing-up is at most 4 – the effect of the blowing-up procedure on an interior vertex is illustrated in Figure 7. All vertices on $\partial D'$ after blowing up have valence at most 3. Vertices on ∂B_{-m} also have valence at most 3 and those in the interior of B_{-m} have valence at most 4. So when B_{-m} is glued onto D' along τ , no vertices of valence greater than 4 are introduced, except possibly at the identified vertices v_1 and v_2 at the start and finish of the z^m subword of ∂D – there is a valence 2 vertex u on ∂B_{-m} for all m , and we can assume u is identified with v_1 and v_2 ; as v_1 and v_2 have valence at most 3 in D' , the resulting vertex has valence at most 6 in D' .

The bound (i) on $\text{Area}(\tilde{D})$ arises from summing the following contributions.

- $\text{Area}(D)$ 2-cells that originate in D .
- The number of 2-cells arising from blowing-up the *strings of digons* is at most $C \text{Area}(D) \text{Diam}(T)$. This is because there is one *string* for each charge and there are at most $C \text{Area}(D)$ charges. Each string has length at most $\text{Diam}(T)$.
- The diagram B_{-m} has area at most m , which is at most $C \text{Area}(D)$ by (7).

There is a natural surjection $\Phi : D' \twoheadrightarrow D$ that collapses the z -corridors introduced in step 3. A maximal tree T' in D' comprises all the edges e that have a single pre-image in T , all the sides of the z -corridors that were inserted in step 3, and the edge path τ .

We specify a maximal tree U in the interior of the diagram B_{-m} . Refer to the boundary components of the concentric annuli in B_{-m} as *rings* and refer to the remaining edges not in *rings* as *radial*. We chose U in such a way that it includes all the *radial* edges, all but one edge in the innermost *ring*, and alternate edges on every other *ring* except the outermost, in which we do not include any edges from the four-sided 2-cells. An example of U is depicted with heavy lines in Figure 8.

Since \tilde{D} consists of B_{-m} and D' joined along τ , the subgraph \tilde{T} of \tilde{D} that consists of all edges in T' or U but not in τ is a maximal tree.

If $\text{Area}(D) = 0$ then $D = \tilde{D}$ and $T = \tilde{T}$, and therefore $T^* = \tilde{T}^*$ consists only of the vertex *at infinity*. So in this case (ii) and (iii) hold with $M = 1$. Assume henceforth that $\text{Area}(D) > 0$. It follows that $m > 0$.

The maximum distance in T' of vertices from τ is at most $\text{Diam}(T)$. Fix a vertex u of the innermost 2-cell in B_{-m} . If k is the least integer greater than $\log_2 m$ then there are $(k - 2)$ z -annuli in B_{-m} and so

$$\text{Diam}_u(U) \leq 4(k - 1) \leq 4 \log_2 m \leq 4 \log_2(C \text{Area}(D)),$$

the final inequality being a consequence of (7). So

$$\text{Diam}(\tilde{T}) \leq 2(\text{Diam}(T) + 4 \log_2(C \text{Area}(D))).$$

Finally we bound $\text{Diam}(\tilde{T}^*)$. From any vertex dual to a 2-cell of B_{-m} in \tilde{D} one can reach a vertex dual to a 2-cell of D' within distance $k - 1 \leq \log_2 m \leq$

$\log_2(C \text{ Area}(D))$ along a path in \tilde{T}^* by successively moving outwards from one annulus to the next. From any vertex dual to a 2-cell of one of the 2-cells inserted in step 3 one can reach a vertex dual one of the 2-cells originating in D by following a path of length at most $\text{Diam}(T)$ in \tilde{T}^* through a corridor. The complementary tree T^* of T is a subtree of \tilde{T}^* . So from any vertex dual one of the 2-cells originating in D one can reach the vertex dual to the 2-cell at infinity along a path of length at most $\text{Diam}(T^*)$. Therefore

$$\text{Diam}(\tilde{T}^*) \leq 2(\log_2(C \text{ Area}(D)) + \text{Diam}(T) + \text{Diam}(T^*)). \quad (8)$$

But each vertex other than that dual to the 2-cell *at infinity* in T^* has valence at most C and so $\text{Area}(D) \leq n C^{\text{Diam}(T^*)}$. We deduce that $\log_2(C \text{ Area}(D)) \leq K \text{Diam}(T^*) + Kn + K$ for some constant K , and in combination with (8) we have (iii).

To complete the proof we show that \tilde{D} can be converted into a \mathcal{P} -van Kampen diagram in such a way that the bounds (i), (ii) and (iii) continue to hold (with a suitable change in the constant M) and without increasing the valence bound from 6 to more than 12. The idea is to replace the 2-cells with boundary words from $\tilde{\mathcal{R}} \setminus \mathcal{R}$ with \mathcal{P} -van Kampen diagrams as follows.

We triangulate the 2-cells with boundary words in $\{z, z^{-1}\}^*$ of length four or five as illustrated in the left-hand and middle diagrams in Figure 9 in the cases z^4 and z^5 . The remaining words in $\tilde{\mathcal{R}} \setminus \mathcal{R}$ are of the form $\tilde{r} = a_1 z a_2 z \dots a_p z$ for some $r = a_1 a_2 \dots a_p$ in $\mathcal{R}^{\pm 1}$. We replace 2-cells with such a boundary word \tilde{r} by a \mathcal{P} -van Kampen diagram made up of $\ell(\tilde{r}) + 1$ 2-cells following the pattern of the example illustrated in the right-hand diagram of Figure 9. Of the 2-cells in this diagram $\ell(\tilde{r})/2$ have commutators $[a_i, z]$ as boundary words, one has boundary word r , and the remaining $\ell(\tilde{r})/2$ have boundary words $z^2 z^{-1}$.

In this procedure the valences of vertices are increased from at most 6 to at most 12 because in the diagrams for words in $\tilde{\mathcal{R}} \setminus \mathcal{R}$ constructed in the previous paragraph, all the boundary vertices have valence at most 3. The area is increased by no more than a constant factor, and one can obtain a maximal tree by extending \tilde{T} and in doing so one does not increase its diameter by more than an additive constant or change the diameter of the complementary tree \tilde{T}^* by more than a multiplicative constant. \blacksquare

Lemma 7.3. *Let D be a diagram and $G := D^{(1)}$. Assume that the valences of all vertices in D are at most K . Then*

$$\text{Diam}(G^*) \leq K(\text{Diam}(G) + 1).$$

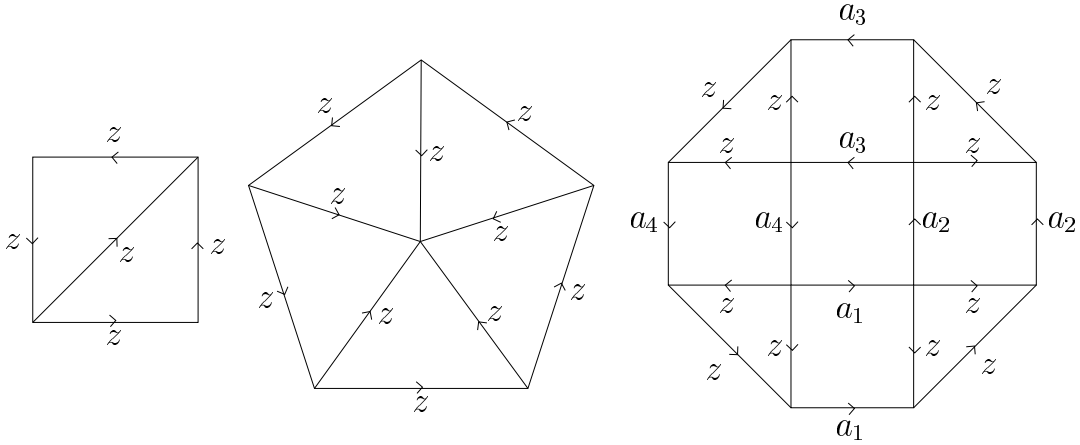

Figure 9: \mathcal{P} -van Kampen diagrams for z^4 , z^5 and $a_1za_2za_3za_4z$

In particular, $\text{GL}(D) \leq K(2 \text{Diam}(D) + 1)$.

Proof. Suppose a^* and b^* are vertices in G^* . Let a and b be vertices of G in the boundaries of the 2-cells dual to a^* and b^* respectively. Let γ be a geodesic in G from a to b . The number of vertices on γ is $(\ell(\gamma) + 1) \leq \text{Diam}(G) + 1$. Let $\bar{\gamma}$ be the subdiagram of the dual diagram to D consisting of the 2-cells dual to vertices on γ . There is a path in $\bar{\gamma}^{(1)}$ (and hence in G^*) from a^* to b^* . As the total number of edges in $\bar{\gamma}^{(1)}$ is at most $K(\text{Diam}(G) + 1)$, we get the required bound. ■

Proof of Theorem 7.1. Suppose w is a length n edge-circuit in \mathcal{P} and that D is a \mathcal{P} -van Kampen diagram for w for which $\text{DlogA}(D) = \text{DlogA}(n)$. Take T to be a maximal geodesic tree in $D^{(1)}$. Then by Proposition 7.2 there is a constant $M > 0$, depending only on \mathcal{P} , such that there is a \mathcal{P} -van Kampen diagram \tilde{D} for w whose vertices have valence at most 12 and that satisfies

$$\text{Diam}(\tilde{D}) \leq M(1 + \text{Diam}(D) + \log_2(\text{Area}(D) + 1)) = M(1 + \text{DlogA}(n)).$$

Via Lemma 7.3 this leads to a bound on $\text{GL}(\tilde{D})$ from which we can conclude that $\text{GL} \preceq \text{DlogA}$.

The reverse bound $\text{DlogA} \preceq \text{GL}$ is more straight-forward and is the subject of the next proposition (and does not require the hypothesis that the presentation \mathcal{P} be fat). ■

Proposition 7.4. *The filling functions GL and DlogA for a finite presentation \mathcal{P} satisfy $\text{DlogA} \preceq \text{GL}$.*

Proof. This follows from the inequalities (1) and (5) of Proposition 2.4 in [13] since the length of the longest defining relator bounds the valence of all the vertices in the dual van Kampen diagram, with the possible exception of the vertex *at infinity*. Inequality (1) is used to bound the diameter term in DlogA by gallery length. Inequality (5) exploits the bounded valence of the dual graph and leads to a bound on the log-area term in DlogA by gallery length. ■

A further consequence of the diagram constructions of Proposition 7.2 is that in a *fat* finite presentation we can bound DlogA in terms of FL .

Proposition 7.5. *For fat finite presentations \mathcal{P} we have $\text{DlogA} \preceq \text{FL}$.*

Proof. Since $\text{FL} \simeq \text{DGL}$ for *fat* finite presentations by Theorem 7.1 of [13], it suffices to prove that $\text{DlogA} \preceq \text{DGL}$.

Let B be the maximum length of the defining relators in \mathcal{P} . Suppose that D is a van Kampen diagram for w and T is a maximal tree in $D^{(1)}$ for which $\text{DGL}(w) = \text{DGL}(D) = \text{Diam}(T) + \text{Diam}(T^*)$. Then for the diagram \tilde{D} of Proposition 7.2 we can use (iii) to give: $\text{Diam}(\tilde{T}^*) \leq M(\text{DGL}(D) + n)$, where $n := \ell(w)$. It follows that $\text{Diam}(\tilde{D}) \leq B M(\text{DGL}(D) + n) + n/2$.

Now the area of \tilde{D} is at most $M \text{Area}(D)(1 + \text{Diam}(T))$ by (i). But

$$\text{Area}(D) \leq n(B - 1)^{\text{Diam}(T^*)}$$

by (5) of Proposition 2.4 of [13]. So $\log_2(1 + \text{Area}(\tilde{D})) \leq K \text{DGL}(D) + Kn + K$ for some constant $K > 0$. Deduce that for some constant $K' > 0$,

$$\text{DlogA}(D) = \text{Diam}(\tilde{D}) + \log_2(1 + \text{Area}(\tilde{D})) \leq K' \text{DGL}(D) + K'n + K'.$$

So $\text{DlogA} \preceq \text{DGL}$. ■

8 Estimates on gallery length and filling length

A first application of Theorem 7.1 is a concise proof of the second half of the following result.

Theorem 8.1. *Suppose \mathcal{P} and \mathcal{Q} are finite presentations for quasi-isometric groups. Then $\text{FL}_{\mathcal{P}} \simeq \text{FL}_{\mathcal{Q}}$. If, in addition, \mathcal{P} and \mathcal{Q} are both fat then $\text{GL}_{\mathcal{P}} \simeq \text{GL}_{\mathcal{Q}}$.*

Proof. We will briefly recall the well known proof [1] that Area is a quasi-isometry invariant of finitely presented groups up to \simeq -equivalence, and we will then adapt it to prove our theorem.

Define $F : C(\mathcal{P})^{(0)} \rightarrow C(\mathcal{Q})^{(0)}$ to be a quasi-isometry from the 0-skeleton of $C(\mathcal{P})$ to that of $C(\mathcal{Q})$ and let $G : C(\mathcal{Q})^{(0)} \rightarrow C(\mathcal{P})^{(0)}$ be a quasi-inverse for F . Suppose w is an edge-circuit in $C(\mathcal{P})$. Join the images under F of adjacent vertices of w by geodesics to form an edge-circuit \hat{w} in $C(\mathcal{Q})$. Given a van Kampen diagram $\Phi : \hat{D} \rightarrow C(\mathcal{Q})$ for \hat{w} , use $G \circ \Phi|_{\hat{D}^{(0)}}$ to map the vertices of \hat{D} to $C(\mathcal{P})^{(0)}$. Joining the images of end points of edges in \hat{D} by geodesics, and then filling the faces with minimal area diagrams makes a van Kampen diagram $\bar{D} \rightarrow C(\mathcal{P})$ for an edge-circuit \bar{w} in $C(\mathcal{P})$. An annular diagram A of bounded width is then attached to the boundary of \bar{D} to make a van Kampen diagram D for w . Comparing the area of \hat{D} with that of D leads to the proof that Area is a quasi-isometry invariant.

To show that FL is a quasi-isometry invariant, one induces a shelling of D from a shelling of \hat{D} in the way we now sketch. Shell D by first radially shelling the annulus A , leaving only a path p (of length depending only on \mathcal{P} and \mathcal{Q}) from the base point of D to \bar{D} , then shell \bar{D} mimicking a shelling of \hat{D} , and finally shell p .

Similarly, the methods of [1] can be extended to (Area, Diam)-pairs. Thus one sees DlogA to be a quasi-isometry invariant. We then use Theorem 7.1 to show that GL is a quasi-isometry invariant of finite fat presentations up to equivalence, which completes the argument. ■

Theorem 7.1 is used to calculate upper bounds on gallery length in the following theorem.

Theorem 8.2.

8.2.1. *The gallery length function of any finite presentation of a group admitting a polynomial isoperimetric inequality of degree $d \geq 2$ admits a polynomial upper bound of degree $d - 1$.*

8.2.2. *The gallery length function of the presentation $\langle x, y, s, t \mid [x, y] = 1, txt^{-1} = x^2, sys^{-1} = y^2 \rangle$, due to Bridson, admits a linear upper bound.*

If Conjecture 5.4 holds then the filling length functions admit the same upper bounds.

Proof. For 8.2.1 and 8.2.2 we apply Theorem 7.1 to the (Area,Diam)-pairs (n^d, n^{d-1}) and (E^n, n) for \mathcal{P} (up to common multiplicative constants) respectively. This (Area,Diam)-pair for 8.2.1 is [11, Theorem 2] and that for 8.2.2 is a consequence of the computations in §5 of [12].

The coda follows from Theorem 1.2. ■

In the context of 8.2.1 we mention that it is proved in [20, Corollary 5.5] that finitely presented groups that admit quadratic isoperimetric functions also admit linear upper bounds on their filling length functions. This adds credence to Conjecture 5.4. We also note that in the case when $d = 2$, the linear bound of 8.2.1 applies in particular to Thompson’s group F on account of the recent result of Guba [16].

Theorem 8.3. *Asynchronously combable groups have filling length functions admitting linear upper bounds. This includes*

8.3.1. *Fundamental groups of finite graphs of groups with finitely generated free vertex and edge groups (for example, the Baumslag-Solitar groups $BS(p, q) = \langle x, y \mid y^{-1}x^py = x^q \rangle$).*

8.3.2. *Fundamental groups of compact, geometrizable 3-manifolds.*

8.3.3. *Split extensions of hyperbolic or abelian groups by asynchronously combable groups.*

Proof. It is a result of the first author, expressed with the notation $LNCH_1$ in [9, Theorem 3.1], that the filling length functions of asynchronously combable groups admit linear upper bounds.

That the groups listed are asynchronously combable follows from Theorem F and Corollary E1 of [2] for 8.3.1 and from Bridson [3] for 8.3.2 and 8.3.3. ■

Finitely generated nilpotent groups are also known to have filling length functions that admit linear upper bounds [10], [14], [15]. It is an open question whether or not such groups are asynchronously combable.

The filling length functions of groups with presentations that are *almost convex* in the sense of Cannon also admit linear upper bounds as we will now explain. Recall that a finite presentation \mathcal{P} satisfies Cannon’s almost convexity condition $AC(2)$ when there exist integers K and n_0 with the following properties. For all vertices a, b in the Cayley graph $C(\mathcal{P})^{(1)}$ of \mathcal{P} ,

at an equal distance $n := d(1, a) = d(1, b)$ from the identity, if $d(a, b) \leq 2$ and $n \geq n_0$ then there is an edge-path from a to b of length at most K that is contained in the closed ball $B_n(1)$ of radius n about the identity. (There are also conditions $AC(k)$ for $k \geq 2$, in which $d(a, b)$ is allowed to be at most k rather than at most 2. The proof of the theorem can easily be generalised to apply to $AC(k)$ presentations.)

Theorem 8.4. *The filling length function of any group Γ that has a finite presentation $\mathcal{P} = \langle \mathcal{A} \mid \mathcal{R} \rangle$ satisfying Cannon's almost convexity condition $AC(2)$ admits a linear upper bound.*

Before proving this theorem we adapt a definition of Gromov [14, page 101] to the combinatorial setting of a Cayley 2-complex .

Definition 8.5. Let \mathcal{P} be a finite presentation of a group Γ . Suppose $w_1, w_2 \in (\mathcal{A}^{\pm 1})^*$ are words with $w_1 = w_2$ in Γ and that D is a van Kampen diagram with boundary word $w_2 w_1^{-1}$, read anticlockwise from a base vertex v_1 . Let v_2 be the vertex of the boundary circuit at the end of the word w_2 , as one reads from v_1 . (So $v_1 = v_2$ precisely when either w_1 or w_2 is the empty word.)

Roughly speaking, we define $F_+L(w_1, w_2, D)$ to be the minimal length L such that there is a *combinatorial homotopy of w_1 to w_2 across D* though paths of length at most L that have fixed end points v_1 and v_2 . Formally, a *combinatorial homotopy of w_1 to w_2 across D* is a sequence of van Kampen diagrams $\mathcal{H} = (D_1, D_2, \dots, D_m)$ such that $D_1 = D$ and D_m is a simple edge-path along which one reads w_2 ; each D_{i+1} is obtained from D_i by either a *1-cell collapse*, or a *1-cell expansion*, or a *2-cell collapse* move (see Definition 2.3 in [13]) in such a way that the w_2 portion of the boundary words ∂D_i is never broken¹². Define

$$L(\mathcal{H}) := \max_i \{ \ell(\partial D_i) - \ell(w_2) \}.$$

Then $F_+L(w_1, w_2, D)$ is the minimum of $L(\mathcal{H})$ amongst all *combinatorial homotopies \mathcal{H} of w_1 to w_2 across D* . Define

$$F_+L(w_1, w_2) := \min \{ F_+L(w_1, w_2, D) \mid \text{van Kampen diagrams } D \text{ for } w_2 w_1^{-1} \}.$$

¹²That is, the word one reads anticlockwise around the boundary of D_i starting from the base vertex v_1 begins with an edge-path q along which one reads w_2 , and each 1-cell or 2-cell collapse move $D_i \rightarrow D_{i+1}$ does not collapse an edge of q and each *1-cell collapse* move inserts two edges in such a way that an inverse pair is inserted into the boundary word somewhere after the prefix word w_2 .

Finally we define a function $F_+L : \mathbb{N} \rightarrow \mathbb{N}$ by

$$F_+L(n) := \max \{F_+L(w_1, w_2) \mid \text{words } w_1, w_2 \text{ with } \ell(w_1), \ell(w_2) \leq n \text{ and } w_1 =_{\Gamma} w_2\}.$$

The observation that a combinatorial homotopy \mathcal{H} of w_1 to w_2 across a van Kampen diagram D can be extended to a shelling of D down to the base vertex v_1 leads to the following proposition.

Proposition 8.6. *The functions FL and F_+L for an arbitrary finite presentation are related as follows. For all n ,*

$$\begin{aligned} \text{FL}(2n) &\leq F_+L(n) \\ \text{FL}(2n + 1) &\leq F_+L(n + 1). \end{aligned}$$

In particular, if F_+L admits a linear upper bound then so does FL.

Proof of Theorem 8.4. It will suffice to show that for $n \geq n_0 + 1$,

$$F_+L(n) \leq F_+L(n - 1) + 1 + C,$$

where C is a constant depending only on \mathcal{P} , for then it will follow that $F_+L(n)$ admits a linear bound, and therefore so does $\text{FL}(n)$ by Proposition 8.6.

Fix $n \geq n_0 + 1$. Suppose that $w_1, w_2 \in (\mathcal{A}^{\pm 1})^*$ are two words with lengths $\ell(w_1), \ell(w_2) \leq n$ such that $w_1 =_{\Gamma} w_2$. We will show that

$$F_+L(w_1, w_2) \leq F_+L(n - 1) + 1 + C, \tag{9}$$

where $C := \max \{ F_+L(\max \{1, K\}), F_+L(1 + K) \}$.

We assume that either $\ell(w_1) = n$ or $\ell(w_2) = n$, for otherwise $F_+L(w_1, w_2) \leq F_+L(n - 1)$ and (9) is immediately satisfied.

Case $\ell(w_1) = n$. For $i = 1, 2$ write $w_i = w'_i \alpha_i$ where $\alpha_i \in \mathcal{A}^{\pm 1}$, and let w''_i be a geodesic word with $w'_i =_{\Gamma} w''_i$. Then

$$\begin{aligned} F_+L(w_1, w_2) &= F_+L(w'_1 \alpha_1, w'_2 \alpha_2) \\ &\leq \max \{F_+L(w'_1 \alpha_1, w''_1 \alpha_1), F_+L(w''_1 \alpha_1, w''_2 \alpha_2), F_+L(w''_2 \alpha_2, w'_2 \alpha_2)\} \\ &\leq \max \{1 + F_+L(w'_1, w''_1), F_+L(w''_1 \alpha_1, w''_2 \alpha_2), 1 + F_+L(w''_2, w'_2)\} \\ &\leq \max \{1 + F_+L(n - 1), F_+L(w''_1 \alpha_1, w''_2 \alpha_2)\}. \end{aligned}$$

So we may, in fact, assume that w'_1 and w'_2 are geodesic words, and then, as $\ell(w'_1) = n - 1$, we find $\ell(w'_2) \in \{n - 3, n - 2, n - 1\}$. These three eventualities are illustrated in Figure 10 and we will address each one in turn.

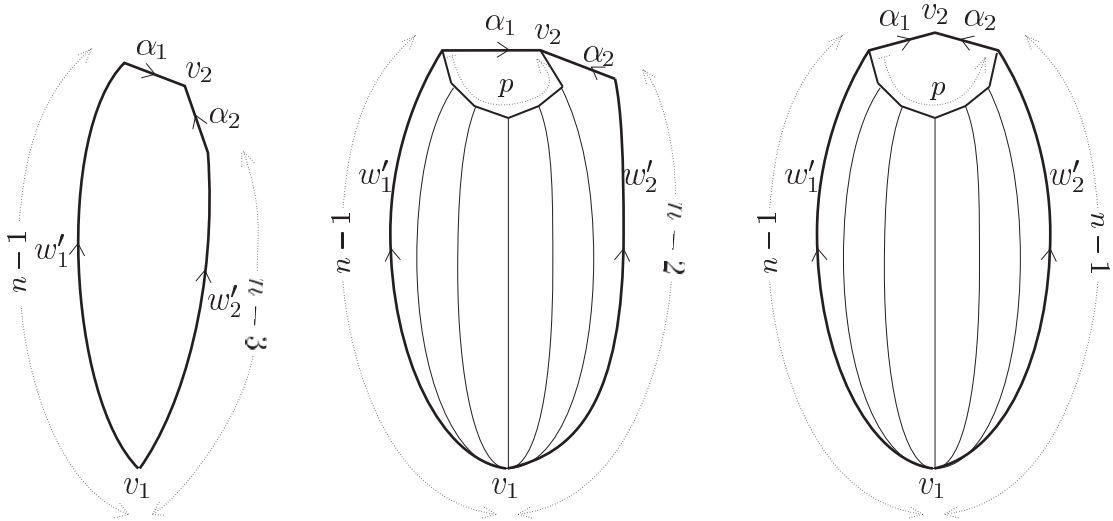

Figure 10: The three cases $\ell(w'_2) = n - 3, n - 2, n - 1$.

Subcase $\ell(w'_2) = n - 3$. We have

$$F_+L(w_1, w_2) \leq F_+L(w'_1, w'_2\alpha_2\alpha_1^{-1}) \leq F_+L(n - 1),$$

and (9) is satisfied.

Subcase $\ell(w'_2) = n - 2$. The length of w_2 is $n - 1$ and we may assume it to be a geodesic word (for it is possible to *combinatorially homotop* w_2 to any word \hat{w}_2 with length at most $n - 1$ and with $w_2 =_{\Gamma} \hat{w}_2$ through paths of length at most $F_+L(n - 1)$).

Let D be a diagram consisting of one 2-cell with boundary circuit of $\ell(w_1) + \ell(w_2)$ edges, and let $\Phi : D^{(1)} \rightarrow C(\mathcal{P})$ be a combinatorial map with image the edge-circuit $w_2w_1^{-1}$ based at the identity $\Phi(v_1) = 1$. As $n - 1 \geq n_0$, the $AC(2)$ condition allows us to extend Φ to a map $\hat{\Phi} : \hat{D}^{(1)} \rightarrow C(\mathcal{P})$ where \hat{D} is the middle diagram of Figure 10; the image $\hat{\Phi}(p)$ of the path p shown is an edge path in $B_{n-1}(1)$ of length at most K , and $\hat{\Phi}$ maps each of the edge paths that run from v_1 to vertices on p (depicted almost vertically) to geodesic in $C(\mathcal{P})$.

We *combinatorially homotop* w_1 to w_2 through paths of lengths within the bound (9) as follows. We first homotop α_1 to p across some van Kampen diagram filling the uppermost 2-cell of the diagram. As $\ell(p) \leq K$ this can be done through paths of length at most $F_+L(\max\{1, K\}) \leq C$. Next we

homotop across van Kampen diagrams filling each of the *vertical* 2-cells in turn working from left to right (in the sense of the depiction of the diagram in Figure 10) as follows.

If u_1 and u_2 are the initial and terminal vertices of an edge e of p then either $d(\hat{\Phi}(u_1), \hat{\Phi}(v_1)) \leq n - 2$ or $d(\hat{\Phi}(u_2), \hat{\Phi}(v_1)) \leq n - 2$, for otherwise the image of the midpoint of e would be outside $B_{n-1}(1)$. Homotop through paths of length at most $F_+L(n - 1)$ with fixed end points u_2 and v_1 if $d(\hat{\Phi}(u_1), \hat{\Phi}(v_1)) \leq n - 2$ and fixed end points u_1 and v_1 otherwise. In the second case next collapse e .

Subcase $\ell(w'_2) = n - 1$. This is similar to the previous subcase. The images of the end vertices of w'_1 and w'_2 are mapped by $\hat{\Phi}$ to points a distance $n - 1$ from 1 in $C(\mathcal{P})^{(1)}$, and so as $n - 1 \geq n_0$, the $AC(2)$ condition may be invoked as before. A homotopy that satisfies (9) begins with a homotopy of α_1 to $p\alpha_2$, and continues with homotopies across the *vertical* 2-cells proceeding from left to right.

Case $\ell(w_2) = n$. The proof is similar to the case $\ell(w_1) = n$. The problem is reduced to considering the three subcases $\ell(w'_1) = n - 3, n - 2, n - 1$ and diagrams that are reflections of those in Figure 10 are examined. So it suffices to note that the minimal length L of paths in a *right-to-left* combinatorial homotopy across the diagrams depicted is within the bound (9). ■

Groups with presentations satisfying various weaker forms of the almost convexity condition are also studied in the literature and their filling length functions are known to admit quadratic upper bounds [19, Theorem 1].

The results listed above suggest a prevalence of finitely presented groups whose gallery length functions admit linear upper bounds and begs the question of whether there exist finite presentations whose gallery length functions or filling length functions grow faster. The answer is that there are many such groups. As we mentioned in Section 5, the word problem for a finite presentation \mathcal{P} is solvable if and only if one of $GL_{\mathcal{P}}$ or $FL_{\mathcal{P}}$ (and hence both) is bounded above by a recursive function. It follows that finite presentations \mathcal{P} for groups with unsolvable word problem have $GL_{\mathcal{P}}$ and $FL_{\mathcal{P}}$ both growing faster than any recursive function. Also the family

$$\Gamma_n = \langle x_0, \dots, x_n \mid x_0^{-1}x_1x_0 = x_1^2, \dots, x_{n-1}^{-1}x_nx_{n-1} = x_n^2 \rangle$$

[14, §4.C₃] of groups that have Dehn functions \simeq -equivalent to an n -times iterated exponential function have filling length and gallery length functions

growing at least as fast as an $(n - 1)$ -times iterated exponential function on account of the inequalities relating $\text{Area}(n)$ to $\text{GL}(n)$ and $\text{Area}(n)$ to $\text{FL}(n)$ discussed in §5 of [13]. Bridson's presentations [4] for groups Φ_m defined for $m \geq 2$ by

$$\langle a_1, \dots, a_m, s, t, \tau \mid \text{for } i < m, s^{-1}a_i s = a_i a_{i+1}, \\ [t, a_i] = [\tau, a_i] = [s, a_m] = [t, a_m] = [\tau, a_m t] = 1 \rangle$$

are contrasting examples. Bridson proves that these have minimal isodiametric functions $\text{Diam}_{\Phi_m}(n) \simeq n^m$ and have Dehn functions $\text{Area}_{\Phi_m}(n) \simeq n^{2m+1}$. Their filling length and gallery length functions lie between $\text{Diam}_{\Phi_m}(n)$ and $\text{Area}_{\Phi_m}(n)$. (This follows from [13, Proposition 2.4].)

However, one can speculate about uniform upper bounds on Diam , FL , GL and Area for particular classes of groups. In this context we mention a conjecture and a question of the first author. The conjecture has been in the public domain for a while but, to our knowledge, is set down in print for the first time here.

Conjecture 8.7. *There is a common recursive upper bound for the Dehn functions of all finitely presentations of linear groups.*

Here, by a *common upper bound*, we mean a function $f : \mathbb{N} \rightarrow \mathbb{N}$ such that all the Dehn functions are $\preceq f(n)$ in the sense of Definition 5.3. The authors are unaware of any finitely presented linear group with Dehn function growing faster than exponential. One might begin by trying to answer the following.

Question 8.8. Do the filling length functions of all finite presentations of polycyclic groups admit linear upper bounds?

A positive answer is already known in the special case of nilpotent groups ([10, Corollary B.1], [20]) and would imply exponential isoperimetric functions for the presentations in question (by [11, Corollary 2] or [14, 5.C]).

9 Relationships between filling functions

We summarise known relationships between filling functions in the following theorem.

Theorem 9.1. *For a finite presentation \mathcal{P} ,*

- (a). $\text{Diam} \preceq \text{DlogA}, \text{GL}, \text{FL}, \text{DGL} \preceq \text{Area}$,
- (b). $\text{DlogA} \preceq \text{GL}$,
- (c). $\log(1 + \text{Area}) \preceq \text{FL}, \text{GL}$,
- (d). $\text{FL} \preceq \text{DlogA}^2$,
- (e). $\log(1 + \text{FL}), \log(1 + \text{GL}) \preceq \text{Diam}$,
- (f). $\log \log(1 + \text{Area}) \preceq \text{Diam}$.

Moreover, if \mathcal{P} is fat then

- (g). $\text{GL} \simeq \text{DlogA} \preceq \text{FL} \simeq \text{DGL}$.

If, in addition, Conjecture 4.3 holds then

- (h). $\text{GL} \simeq \text{DlogA} \simeq \text{FL} \simeq \text{DGL}$.

Proof. The bounds on Diam by DlogA and DGL in (a) are immediate from the definitions, and the bounds by GL and FL follow from (1), (2) of Proposition 2.4 in [13]. That $\text{GL}, \text{DlogA}, \text{FL}, \text{DGL} \preceq \text{Area}$ follows from (3), (4) of Proposition 2.4 in [13] and the easy result that $\text{Diam}(D) \preceq B \text{Area}(D) + \text{Perimeter}(D)$ for a diagram D whose 2-cells all have at most B boundary edges.

We proved (b) in Proposition 7.4. The bound $\log(1 + \text{Area}) \preceq \text{FL}$ of (c) is the *space-time* bound of [11, Corollary 2] or [14, 5.C]. The corresponding bound for GL follows from [13, Proposition 2.4 (5)]. Theorem 1 of [11] implies (d).

The bound $\log(1 + \text{GL}) \preceq \text{Diam}$ of (e) follows from [13, Theorem 5.1]. The Double Exponential Theorem, a recent new proof of which is in §5 of [13] (*cf.* references therein), gives (f). The other bound $\log(1 + \text{FL}) \preceq \text{Diam}$ of (e) is obtained by combining the Double Exponential Theorem with Theorem 1 of [11].

It remains to prove (g) and (h). When \mathcal{P} is a *fat* presentation we get $\text{GL} \simeq \text{DlogA}$ from Theorem 7.1. The equivalence $\text{FL} \simeq \text{DGL}$ is Theorem 7.1 of [13]. The result $\text{DlogA} \preceq \text{FL}$ is Proposition 7.5 above. If Conjecture 5.4 holds then by Theorem 1.2 these four filling functions are all \simeq -equivalent. ■

10 Restricted filling functions

One of the features of the van Kampen diagrams \tilde{D} for null-homotopic words w in a fat presentation \mathcal{P} constructed in Proposition 7.2 is that they have uniformly bounded valence. Remark 7.3 in [13] explains that the same is true of the diagrams \overline{D} constructed in the proof of Theorem 7.1 in [13]. Thus by adding a, in one sense, redundant extra generator z and some apparently innocuous extra defining relators to a finite presentation, we have ensured that every edge-circuit admits a van Kampen diagram in which every vertex valence is at most 12. Moreover, both in Proposition 7.2 and in Theorem 7.1 in [13] we have substantial control on the geometry of that diagram. (Several consequences will be included in Theorem 10.3.) This motivates us to define what we call *restricted filling functions*, where we quantify over all diagrams whose vertices have valence within some specified bounded.

Definition 10.1. Suppose that \mathcal{P} is a finite presentation and that \mathcal{F} is a *diagram measurement* (see Definition 4.2). Fix $k > 0$. Suppose w is an edge-circuit in \mathcal{P} . If w fails to admit a van Kampen diagram in which the valence of every vertex is at most k then $R_k\mathcal{F}(w) := \infty$. Otherwise we define $R_k\mathcal{F}(w)$ to be the minimum of $\mathcal{F}(D)$ over all van Kampen diagrams D for w in which every vertex has valence at most k . Then we define the *restricted filling function* $R_k\mathcal{F} : \mathbb{N} \rightarrow \mathbb{N} \cup \{\infty\}$ by

$$R_k\mathcal{F}(n) := \sup \{R_k\mathcal{F}(w) \mid \text{edge-circuits } w \text{ with } \ell(w) \leq n\}.$$

The bounded valence of the diagrams in Proposition 7.2 implies the following. (It is likely that the bound of 12 can be improved.)

Proposition 10.2. *If \mathcal{P} is a finite fat presentation and \mathcal{F} is any diagram measurement then $R_{12}\mathcal{F}(n) < \infty$ for all n .*

Restricted filling functions have geometric significance in the realm of combinatorial notions of curvature. Suppose we give the *corners*¹³ of the 2-cells in the presentation 2-complex \mathcal{K}^2 (see Section 5) strictly positive *weights* (*i.e. angles*) then the corners of 2-cells in van Kampen diagrams inherit weights (via the map Φ – see Definition 5.1). Then restricted filling functions concern the geometry of diagrams with curvature uniformly bounded away

¹³A *corner* of a 2-cell is one of the subdivision points of its attaching map

from $-\infty$; that is, diagrams for which there is a uniform bound on the sum of the weights at each corner.

In the following theorem we set out some of the properties of the restricted forms of the filling functions we have been discussing.

Theorem 10.3. *Let \mathcal{P} be a fat finite presentation. Fix $k \geq 12$ and define $R := R_k$.*

- (A). *If \mathcal{F} is a filling function for \mathcal{P} then $\mathcal{F} \preceq R\mathcal{F}$.*
- (B). *If (f, g) is an (Area, Diam)-pair then $(f + fg, 1 + g + \log_2(1 + f))$ is an (RArea, RDiam)-pair for \mathcal{P} , up to a common multiplicative constant.*
- (C). *$\text{FL} \simeq \text{RFL} \simeq \text{DGL} \simeq \text{RDGL}$ and $\text{RDlogA} \simeq \text{DlogA}$.*
- (D). *$\text{RDiam} \simeq \text{RGL} \simeq \text{DlogA}$.*

Moreover, if Conjecture 4.3 is true then $\text{RGL} \simeq \text{RDGL}$ and so all the functions from (C) and (D) are \simeq -equivalent.

Proof. The explanation for (A) is that for an edge-circuit w , in the definition of $R\mathcal{F}(w)$ one quantifies over a (non-empty) subset of the van Kampen diagrams that one quantifies over in the definition of $\mathcal{F}(w)$.

To prove (B) use Proposition 7.2 with T a geodesic maximal tree in $D^{(1)}$. The diagram \tilde{D} has area at most $M(f(n) + f(n)g(n))$ by (i) and diameter at most $M(1 + g(n) + \log_2(1 + f(n)))$ by (ii).

For $\text{RDGL} \simeq \text{RFL}$ we note that $\text{RFL} \preceq \text{RDGL}$ is immediate from the inequality relating the diagram measurements FL and DGL in Theorem 3.5 of [13]. The reverse inequality $\text{RDGL} \preceq \text{RFL}$ is a consequence of the constructions used to show $\text{DGL} \preceq \text{FL}$ in the proof of Theorem 7.1 in [13].

We learn from (A) that it suffices to show that $\text{RFL} \preceq \text{FL}$ and $\text{RDlogA} \preceq \text{DlogA}$ in order to establish the remaining equivalences in (C).

We know from (A) that $\text{FL} \preceq \text{RFL}$ and $\text{DGL} \preceq \text{RDGL}$. In the following paragraph we prove that $\text{RFL} \preceq \text{DGL}$ and then in the next paragraph we explain $\text{RDGL} \preceq \text{FL}$. We can then deduce that FL, RFL, DGL and RDGL are all \simeq -equivalent.

Suppose w is an edge-circuit in \mathcal{P} . Suppose that D is a van Kampen diagram for w and T is a maximal tree in $D^{(1)}$ for which $\text{DGL}(w) = \text{DGL}(D) = \text{Diam}(T) + \text{Diam}(T^*)$. Then for the diagram \tilde{D} of Proposition 7.2 we can use (iii) to bound $\text{Diam}(\tilde{T}^*)$ in terms of $\text{DGL}(D)$. We bound the

$\log_2(\text{Area}(D) + 1)$ term in (ii) using $\text{Diam}(T^*)$ (see [13, Proposition 2.4 (5)]), and the result is $\text{Diam}(\tilde{T})$ majorised in terms of $\text{DGL}(D)$. As vertex valences in \tilde{D} are at most 12 we deduce that $RFL \preceq \text{DGL}$.

In §7 of [13] we proved that for a fat presentation \mathcal{P} one has $\text{DGL} \preceq \text{FL}$. Given a null-homotopic word w we took a minimal filling length van Kampen diagram D for w and we constructed a new van Kampen diagram \bar{D} for w for which $\text{DGL}(\bar{D})$ could be bound in terms of $\text{FL}(D)$. As noted in Remark 7.3 of that article, all vertices in the diagram \bar{D} had valences at most 11. So, in fact, our proof amounted to showing that $RDGL \preceq \text{FL}$.

To show $RDlogA \preceq \text{DlogA}$ we suppose that D is a van Kampen diagram for an edge-circuit w for which $\text{DlogA}(D) = \text{DlogA}(w)$. Then the diagram \tilde{D} of Proposition 7.2, with T a geodesic maximal tree in $D^{(1)}$, has all vertex valences at most 12 and by (i),(ii) respectively

$$\begin{aligned} \text{Diam}(\tilde{D}) &\leq M(1 + \text{DlogA}(D)), \\ \log_2(1 + \text{Area}(\tilde{D})) &\leq K \log_2(\text{Area}(D) + 1) + K \text{Diam}(D) + K \end{aligned}$$

for some constant $K > 0$. These two inequalities together give a bound on $RDlogA(\tilde{D})$ in terms of $\text{DlogA}(D)$, from which $RDlogA \preceq \text{DlogA}$ follows.

Lemma 7.3 and its dual reformulation together imply that $RDiam \simeq RGL$. The result $RGL \preceq \text{DlogA}$ comes from analysing our proof of $GL \preceq \text{DlogA}$ (part of Theorem 7.1): we constructed a diagram \tilde{D} as set out in Proposition 7.2, and all the vertices of this diagram had valences at most 12.

For the reverse bound $\text{DlogA} \preceq RGL$ we exploit (C) that tells us it is enough to show $RDlogA \preceq RGL$. The proof of this is the same as that of Proposition 7.4. This completes the proof of (D).

That Conjecture 4.3 implies $RGL \simeq RDGL$ is a direct consequence of the definitions. ■

The final conclusion of the theorem says that (assuming Conjecture 4.3) the restricted filling functions $RDiam$, RFL , RGL , $RDGL$, $RDlogA$ (as well as FL , DGL and DlogA) for a fat finite presentation are all \simeq -equivalent. Thus in the *restricted* case the universe of the filling functions we have been considering collapse to just two: RFL ($\simeq \text{FL}$) and $R\text{Area}$, the restricted analogues of the (non-deterministic) space and time complexity measures, respectively, of the crude method of attacking the by word problem by exhaustively applying relators. Whether or not the the non-restricted case simplifies in a similar way is open (*cf.* §5 of [13]).

References

- [1] J. M. Alonso. Inégalitiés isopérimétriques et quasi-isométries. *C.R. Acad. Sci. Paris Ser. 1 Math.*, 311:761–764, 1990.
- [2] G. Baumslag, S. M. Gersten, M. Shapiro, and H. Short. Automatic groups and amalgams. *J. Pure Appl. Algebra*, 76(3):229–316, 1991.
- [3] M. R. Bridson. Combing of semidirect products and 3-manifold groups. *Geom. Funct. Anal.*, 35(3):263–278, 1993.
- [4] M. R. Bridson. Asymptotic cones and polynomial isoperimetric inequalities. *Topology*, 38(3):543–554, 1999.
- [5] M. R. Bridson. The geometry of the word problem. In M. R. Bridson and S. Salamon, editors, *Invitations to Geometry and Topology*, pages 33–94. O.U.P., 2002.
- [6] M. Dehn. Über unendliche diskontinuierliche Gruppen. *Math. Ann.*, 71:116–144, 1912.
- [7] R. Diestel. *Graph Theory*, volume 173 of *Graduate Texts in Mathematics*. Springer-Verlag, 2nd edition, 2000.
- [8] S. M. Gersten. Isoperimetric and isodiametric functions. In G. Niblo and M. Roller, editors, *Geometric group theory I*, number 182 in LMS lecture notes. Camb. Univ. Press, 1993.
- [9] S. M. Gersten. Asynchronously automatic groups. In Charney, Davis, and Shapiro, editors, *Geometric group theory*, pages 121–133. de Gruyter, 1995.
- [10] S. M. Gersten, D. F. Holt, and T. R. Riley. Isoperimetric functions for nilpotent groups. *GAF*, 13:795–814, 2003.
- [11] S. M. Gersten and T. R. Riley. Filling length in finitely presentable groups. *Geom. Dedicata*, 92:41–58, 2002.
- [12] S. M. Gersten and T. R. Riley. Filling radii of finitely presented groups. *Quart. J. Math. Oxford*, 53(1):31–45, 2002.

- [13] S. M. Gersten and T. R. Riley. The gallery length filling function and a geometric inequality for filling length. Preprint, <http://www.math.utah.edu/~gersten/grouptheory.htm/>, 2003.
- [14] M. Gromov. Asymptotic invariants of infinite groups. In G. Niblo and M. Roller, editors, *Geometric group theory II*, number 182 in LMS lecture notes. Camb. Univ. Press, 1993.
- [15] M. Gromov. *Carnot-Carathéodory spaces seen from within*, volume 144 of *Progress in Mathematics*, pages 79–323. Birkhäuser, 1996.
- [16] V. S. Guba. The Dehn function of Richard Thompson’s group F is quadratic. Preprint, 2001.
- [17] R. C. Lyndon and P. E. Schupp. *Combinatorial Group Theory*. Springer-Verlag, 1977.
- [18] A. Yu. Ol’shanskii. *Geometry of defining relations in groups*. Kluwer Academic Publ., 1991. [Russian original, Nauka Publ., 1989].
- [19] T. R. Riley. The geometry of groups satisfying weak almost-convexity or weak geodesic-combability conditions. *Journal of Group Theory*, 5(4):513–525, 2002.
- [20] T. R. Riley. Higher connectedness of asymptotic cones. *Topology*, 42:1289–1352, 2003.

STEVE M. GERSTEN

Mathematics Department, 155S. 1400E., Rm. 233, Univ. of Utah, Salt Lake City, UT 84112, USA

gersten@math.utah.edu, <http://www.math.utah.edu/~gersten/>

TIM R. RILEY

Mathematics Department, 10 Hillhouse Avenue, P.O. Box 208283, New Haven, CT 06520-8283, USA

tim.riley@yale.edu, <http://www.math.yale.edu/users/riley/>