

**ENHANCED NILPOTENT REPRESENTATIONS OF
A CYCLIC QUIVER**

by

Casey Patrick Johnson

A dissertation submitted to the faculty of
The University of Utah
in partial fulfillment of the requirements for the degree of

Doctor of Philosophy

Department of Mathematics

The University of Utah

August 2010

Copyright © Casey Patrick Johnson 2010

All Rights Reserved

The University of Utah Graduate School

STATEMENT OF DISSERTATION APPROVAL

The dissertation of Casey Patrick Johnson

has been approved by the following supervisory committee members:

Peter E. Trapa, Chair 5/27/2010
Date Approved

Dan M. Ciubotaru, Member 5/27/2010
Date Approved

Henryk Hecht, Member 5/27/2010
Date Approved

Matthew Ondrus, Member 5/27/2010
Date Approved

Gordan Savin, Member 5/27/2010
Date Approved

and by Aaron Bertram, Chair of
the Department of Mathematics

and by Charles A. Wight, Dean of The Graduate School.

ABSTRACT

We define a set of “enhanced” nilpotent quiver representations that generalizes both the enhanced nilpotent cone and the colored nilpotent cone. This set admits an action by an associated algebraic group K with finitely many orbits. We define a combinatorial set that parametrizes the set of orbits under this action and we derive a purely combinatorial formula for the dimension of an orbit. Finally, we present a conjectural combinatorial description of the closure order.

For Kirsten.

CONTENTS

ABSTRACT	iii
LIST OF FIGURES	vii
NOTATION AND SYMBOLS	viii
ACKNOWLEDGMENTS	ix
CHAPTERS	
1. INTRODUCTION	1
1.1 The enhanced nilpotent cone	1
1.2 Nilpotent cyclic quiver representations	2
1.3 Main results	3
2. COLORED VECTOR SPACES	5
2.1 Colored vector spaces	5
2.2 Colored change of basis	8
2.3 Colored endomorphisms	9
3. THE COLORED NILPOTENT CONE	13
3.1 Colored Jordan bases	13
3.2 Colored partitions	14
3.3 The colored Jordan normal form	17
4. THE ENHANCED COLORED NILPOTENT CONE	23
4.1 Marked colored partitions	23
4.2 Normal bases	28
4.3 Connections to classical orbits	32
4.4 An alternative parametrization	36
5. THE DIMENSION OF AN ORBIT	41
5.1 Known examples	41
5.2 The dimension formula	42
6. NILPOTENT ORBIT CLOSURES	47
6.1 Resolution of singularities	47
6.2 The closure order	49
6.3 Colored covering relations	53
6.4 An alternative criterion	57

7. ENHANCED NILPOTENT ORBIT CLOSURES	66
7.1 Resolution of singularities	66
7.2 More geometry	68
7.3 The enhanced closure order	70
7.4 First case	71
7.5 Same-shape pairs	75
8. ENHANCED COVERING RELATIONS	79
8.1 Same-shape covering relations	79
8.2 Types I and II	83
8.3 Future efforts	84
REFERENCES	86

LIST OF FIGURES

3.1 A 3-colored partition of signature $(6, 7, 5)$	16
3.2 A signed partition of signature $(8, 10)$	22
4.1 A striped 3-bipartition.	24
4.2 Orbits parametrized by signed 2-bipartitions.	33
4.3 Orbits parametrized by minimal bipartitions.	35
4.4 Orbits parametrized by characteristic bipartitions.	40

NOTATION AND SYMBOLS

\mathbb{Z}	The additive group of integers.
$\mathbb{Z}^{\geq 0}$	The set of nonnegative integers.
\mathbb{N}	The additive semigroup of positive integers.
\mathbb{R}	The field of real numbers.
\mathbb{C}	The field of complex numbers.
n	A fixed positive integer.
$\mathbb{Z}/k\mathbb{Z}$	The cyclic group with k elements.
$[i]$	The coset $i + k\mathbb{Z} \in \mathbb{Z}/k\mathbb{Z}$
$\langle i \rangle$	The smallest nonnegative element of $[i]$.
$\lfloor \cdot \rfloor$	The floor function: $\lfloor x \rfloor = \max\{y \in \mathbb{Z} \mid y \leq x\}$.
$\lceil \cdot \rceil$	The ceiling function: $\lceil x \rceil = \min\{y \in \mathbb{Z} \mid y \geq x\}$.
$\text{End}(W)$	The space of linear endomorphisms of the finite-dimensional vector space W .
$GL(W)$	The group of invertible elements of $\text{End}(W)$.
$\langle \cdot \rangle$	The linear span of a vector or set of vectors in a vector space W .
$A + B$	The span of $A \cup B$.
\overline{A}	The Zariski closure in X of an algebraic subvariety $A \subset X$.

ACKNOWLEDGMENTS

No thesis is truly the work of a single person. In my case, I must recognize Peter Trapa for suggesting my research topic and for never ceasing to provide me with new ideas to consider. The insight of my office mates, Scott Crofts and Matt Housley, has been indispensable. I also thank Anthony Henderson and Pramod Achar for laying the groundwork for my results and providing me with valuable feedback.

In a larger sense, though, this thesis is the culmination of over twenty years of schooling. Throughout this time, many people have had a hand in shaping who I am—both as a student and as a human being. Notable among these are a few teachers that have particularly impacted me. Miss Belliston gave me the resources to excel. Mrs. Coltrin never let me give up. Mrs. Harding taught me the value of digging deeper to understand rather than merely accepting a superficial knowledge. Mrs. Berg never allowed me to be satisfied with less than my best.

As a college student, a number of professors have been instrumental in making sure that I, personally, have found the study of mathematics to be exciting and fulfilling. Among these are John Dallon, Chris Grant, Jim Cannon, Wayne Barrett, and Dragan Miličić. These individuals and many more, including the support staffs at BYU and the University of Utah, have made my time as a student a period of great personal growth and enjoyment.

The highest praise of all, however, goes to my family. I can never repay my parents and siblings for their continual support and encouragement of my love of learning. I will always be grateful to my wife, Kirsten, for taking a chance on a guy like me. I am here only because she has given up so much of her time and sacrificed so many of her own plans to accommodate my schooling. Lastly, I must recognize my children, Katherine and Logan, without whom this thesis would have been completed much sooner and been much less meaningful.

CHAPTER 1

INTRODUCTION

1.1 The enhanced nilpotent cone

In his study of the exotic Springer correspondence in [4] and the exotic Deligne-Langlands correspondence in [5], Kato introduces an object that he calls the *exotic nilpotent cone*. If U is a $2k$ -dimensional symplectic vector space, let N_0 denote the set of nilpotent self-adjoint endomorphisms of U . The exotic nilpotent cone is the set $U \times N_0$ and it admits a natural action by $K = Sp(U)$.

It has long been known that if W is the Weyl group of type C_k then the set \widehat{W} of equivalence classes of irreducible representations of W is in bijection with the set of pairs $(\mu; \nu)$ of partitions such that $|\mu| + |\nu| = k$. Kato showed that this set of “bipartitions of size k ” is also naturally in bijection with $K \backslash (U \times N_0)$, the set of orbits of K on $U \times N_0$, which gives an alternative parametrization of \widehat{W} by $K \backslash (U \times N_0)$.

There are two *enhanced nilpotent cones* closely associated to the exotic nilpotent cone. If V is a linear space and $\mathcal{N}(V)$ denotes the set of nilpotent linear endomorphisms of V then the enhanced nilpotent cone of V is the set $V \times \mathcal{N}(V)$. It is easy to see that if V is a Lagrangian subspace of U then $V \times \mathcal{N}(V) \subset U \times N_0 \subset U \times \mathcal{N}(U)$. On each of these varieties there is a natural change-of-basis action, namely

- $GL(V)$ acts on $V \times \mathcal{N}(V)$,
- $Sp(U)$ acts on $U \times N_0$,
- $GL(U)$ acts on $U \times \mathcal{N}(U)$.

Travkin proves in [7] that $GL(V) \backslash (V \times \mathcal{N}(V))$ is parametrized by the set of bipartitions of size k , so $GL(U) \backslash (U \times \mathcal{N}(U))$ is parametrized by the set of bipartitions of size $2k$. Achar and Henderson independently prove the same result in [1], going on to show that there is a natural embedding $GL(V) \subset Sp(U) \subset GL(U)$ and that these three parametrizations

have the important compatibility property given below. In the statement that follows, let $\mu \cup \mu$ denote the partition of size $2k$ obtained from μ by doubling the multiplicity of each row.

Theorem 1.1.1. (*Achar-Henderson*) *If $(\mu; \nu)$ is a bipartition and $\mathcal{O}_{\mu; \nu}$ and $\mathbb{O}_{\mu; \nu}$ denote the corresponding enhanced and exotic orbits, respectively, then $\mathcal{O}_{\mu; \nu} \subset \mathbb{O}_{\mu; \nu} \subset \mathcal{O}_{\mu \cup \mu; \nu \cup \nu}$.*

Since each of these actions yields finitely many orbits and the groups acting are algebraic, we have the natural partial order on orbits defined by closure. That is, we can say that $\mathcal{O}_{\mu; \nu} \leq \mathcal{O}_{\mu'; \nu'}$ if and only if $\mathcal{O}_{\mu; \nu}$ is contained in the Zariski closure of $\mathcal{O}_{\mu'; \nu'}$. Achar and Henderson define a combinatorial partial order \leq on the set of bipartitions of size k and prove the following.

Theorem 1.1.2. (*Achar-Henderson*) *The following are equivalent:*

1. $(\mu; \nu) \leq (\mu'; \nu')$
2. $\mathcal{O}_{\mu; \nu} \subset \overline{\mathcal{O}_{\mu'; \nu'}}$
3. $\mathbb{O}_{\mu; \nu} \subset \overline{\mathbb{O}_{\mu'; \nu'}}$

Henderson has proved in [3] that, for each λ , $\overline{\mathbb{O}_{\emptyset; \nu}}$ has the same intersection cohomology as $\overline{\mathcal{O}_{\emptyset; \nu}}$, with all degrees doubled. He and Achar conjecture in [1] that the same holds for all bipartitions $(\mu; \nu)$; they also outline a programme for investigating this conjecture.

1.2 Nilpotent cyclic quiver representations

The Achar-Henderson parametrization begins with the well-known fact that if V is a finite-dimensional linear space then the Jordan normal form parametrizes the conjugacy classes of nilpotent matrices. Since the Jordan form of a nilpotent matrix corresponds to a partition of size $k = \dim V$, there is a natural bijection

$$\{\text{partitions of size } k\} \longleftrightarrow \{\text{conjugacy classes in } \mathcal{N}(V)\}.$$

Furthermore, $\mathcal{N}(V)$ embeds in $V \times \mathcal{N}(V)$ as $\{0\} \times \mathcal{N}(V)$ and the set of partitions embeds in the set of bipartitions via $\nu \mapsto (\emptyset; \nu)$ in such a way $\mathcal{O}_{\nu} \cong \mathcal{O}_{\emptyset; \nu}$. In other words, the parameter set reduces to the classical parametrization when the enhanced nilpotent orbits are just ordinary nilpotent orbits in disguise.

On the other hand, we can generalize the nilpotent cone in another way. Let Γ be a cyclic quiver of order n . We can view Γ as the set $X = \mathbb{Z}/n\mathbb{Z}$ with directed edges

$e_i = (i, i + [1]), i \in X$. A representation of Γ assigns to each $i \in X$ a finite-dimensional vector space V_i and a linear transformation $x_i \in \text{Hom}(V_i, V_{i+[1]})$. We say that such a representation is nilpotent if $x_{[n-1]} \circ \cdots \circ x_{[1]} \circ x_{[0]} \in \text{End}(V_{[0]})$ is nilpotent.

If we fix V_i for each $i \in X$, we can consider the set \mathcal{N} of nilpotent quiver representations of Γ with the chosen underlying vector spaces. Then $K = \prod_{i \in X} GL(V_i)$ naturally acts on $V = \sum_{i \in X} V_i$, hence on \mathcal{N} by conjugation. Thus, we can consider the problem of parametrizing the set $K \backslash \mathcal{N}$ of orbits of this action. Kempken solves this problem in [6], showing that these orbits are parametrized by a generalization of the classical notion of partition, which we will call ‘‘colored partitions.’’ In addition, Kempken presents a combinatorial description of the closure order in $K \backslash \mathcal{N}$. We present a full exposition of this parametrization, culminating in theorem 3.3.5. The combinatorial closure order consists of theorems 6.2.2 and 6.4.13.

The case where Γ is a 2-cycle is of particular interest. If G is the real Lie group $U(p, q)$ with Lie algebra $\mathfrak{g} = \mathfrak{u}(p, q)$ then the set of nilpotent adjoint orbits in \mathfrak{g} is parametrized by the set of signed (2-colored) partitions of signature (p, q) in, e.g., [2]. On the other hand, if $K = GL(p, \mathbb{C}) \times GL(q, \mathbb{C})$ and

$$\mathcal{N} = \{(x, y) \in \text{Hom}(\mathbb{C}^p, \mathbb{C}^q) \times \text{Hom}(\mathbb{C}^q, \mathbb{C}^p) \mid x \circ y : \mathbb{C}^q \rightarrow \mathbb{C}^q \text{ is nilpotent}\}$$

then the Kostant-Sekiguchi bijection is a natural one-to-one correspondence between the set of nilpotent adjoint orbits and $K \backslash \mathcal{N}$. Thus, we can view the set of adjoint orbits as a set of orbits of representations over a cyclic quiver of order two.

1.3 Main results

The objective of this paper is to present a framework that generalizes both of these constructions. We ‘‘enhance’’ the set of nilpotent quiver representations of a cyclic graph by taking its product with the natural representation V_i of K , for some $i \in X$. K naturally acts on $V_i \times \mathcal{N}$ with finitely many orbits. In fact, we will take the product of \mathcal{N} with the slightly larger space $\tilde{V} = \bigcup_{i \in X} V_i$, eliminating the need to make a choice of $i \in X$.

In theorem 4.2.8 we show that the set $K \backslash (\tilde{V} \times \mathcal{N})$ of orbits is finite and is parametrized by the set of ‘‘striped n -bipartitions’’ defined in section 4.1. Essentially, a striped n -bipartition is a partition that is colored to reflect the quiver structure and also divided in two parts, each of which is a natural deformation of a partition. As a consequence, we obtain multiple parametrizations of $K \backslash (V_i \times \mathcal{N})$.

In the case $n = 1$ the set of striped n -bipartitions reduces precisely to the set of bipartitions, yielding the Achar-Henderson parametrization. On the other hand, we have the natural embedding $\{0\} \times \mathcal{N} \subset \tilde{V} \times \mathcal{N}$ and we will show that the parameters that correspond to orbits in $\{0\} \times \mathcal{N}$ can be viewed as colored partitions in a natural way that reduces to Kempken's parametrization of $K \setminus \mathcal{N}$.

We derive formulas for computing the dimension of an orbit given its corresponding striped n -bipartition. These formulas quickly reduce to the formulas that have been given by Achar-Henderson and Kempken. We are particularly interested in the case $n = 2$ discussed above. In this setting, the striped n -bipartitions yield especially simple dimension formulas, which are included as corollaries 5.2.7, 5.2.8, and 5.2.9.

With this framework in place, we will be in a position to explore the closure order. We deduce necessary combinatorial criteria for determining if two striped n -bipartitions are comparable in the closure order. These criteria determine a partial order on the set of striped n -bipartitions and we show that the partial order induced by the closure order is a refinement of the combinatorial order. We conjecture that these two partial orders are, in fact, equal. While our effort falls short of a complete proof that this is the case, we present a proof for each of several important cases, as well as evidence that the result holds in the remaining cases.

CHAPTER 2

COLORED VECTOR SPACES

Most of the constructions in this paper rely on the notion of a colored vector space. In this section we introduce colored vector spaces and we develop their basic structure, including a few properties of their automorphisms and endomorphisms. These last give rise to the quiver representations mentioned in section 1.2. Lastly, we classify flags of colored subspaces. This section is elementary in nature, so few proofs are included. In most cases, the claims are explicit enough to suggest a proof.

2.1 Colored vector spaces

Let V be a finite-dimensional vector space over a field \mathbb{F} with (not necessarily nonzero) vector subspaces $V_1, \dots, V_n \subset V$ such that $V = V_1 \oplus \dots \oplus V_n$. The tuple (V, V_1, \dots, V_n) is an n -colored vector space. Throughout this paper the symbol V will refer to the vector space V , together with a prescribed colored structure. We will refer to the elements of $\{1, \dots, n\}$ as *colors*. If $W \subset V$ is a subset, we may write $W_i = W \cap V_i$.

Definition 2.1.1. If $W \subset V$ is an arbitrary subset, the *signature* of W is the function $\xi(W) : \{1, \dots, n\} \rightarrow \mathbb{Z}$ defined by $\xi_i(W) = \dim(\langle W \rangle_i)$. Observe that $\xi(W) = \xi(\langle W \rangle)$.

Lemma 2.1.2. If $W \subset V$ is a subspace then $\dim W \geq \sum_{i=1}^n \xi_i(W)$. If $U \subset W$ then $\xi_i(U) \leq \xi_i(W)$ for each i .

Definition 2.1.3. We say that a subspace $W \subset V$ is *colored* if $\dim W = \sum_{i=1}^n \xi_i(W)$. A vector $v \in V$ is colored if $\langle v \rangle$ is colored. A finite subset of V is colored if each of its elements is colored.

We can think of colored subspaces as those that lie “squarely” in V , relative to V_1, \dots, V_n . For example, if $V = \mathbb{R}^2$ with V_1 and V_2 the two coordinate axes then (V, V_1, V_2) is a colored vector space. In this case, the only colored subspaces of V are $0, V_1, V_2$, and

V . On the other hand, if $n = 1$ and $V = \mathbb{R}^2$ then we have the colored vector space (V, V) and each subspace of V is colored.

Lemma 2.1.4.

1. V is colored with $\xi_i(V) = \dim V_i$.
2. $0 \subset V$ is colored with $\xi_i(0) = 0$.
3. If $W \subset V$ is a subspace then $W_1 + \cdots + W_n$ is the largest colored subspace of W and $\xi(W) = \xi(W_1 + \cdots + W_n)$.

Proposition 2.1.5. *If W is a subspace of V then the following are equivalent.*

1. W is colored,
2. $W = W_1 + \cdots + W_n$,
3. (W, W_1, \dots, W_n) is a colored vector space,
4. W has a colored basis,
5. Each $w \in W$ can be written (uniquely) as $w = w_1 + \cdots + w_n$, with $w_i \in W_i$.
6. If $w \in W$ is written $w = w_1 + \cdots + w_n$ with $w_i \in V_i$ then $w_i \in W$.

Corollary 2.1.6. *If $W \subset V$ is a subspace then there is a colored subspace $U \subset V$ such that $V = U \oplus W$.*

Proof. Let U be any colored subspace such that $U + W = V$. We know that such U exist because V is an example. The proposition guarantees a colored basis \mathcal{B} for U . We may also choose any basis \mathcal{A} of W . If $U \cap W \neq 0$ then there is a nontrivial dependence relation among the elements of $\mathcal{A} \cup \mathcal{B}$. Since \mathcal{A} is a linearly independent set, this dependence relation must nontrivially include an element $v \in \mathcal{B}$. Clearly, $U' = \langle \mathcal{B} \setminus \{v\} \rangle$ is colored with $U' + W = V$ and $\dim U' < \dim U$. The result follows by induction. \square

Corollary 2.1.7. *The set of colored vectors in V is precisely $\tilde{V} = \bigcup_{i=1}^n V_i$.*

Definition 2.1.8. We define the “color” function $\chi : \tilde{V} \setminus \{0\} \rightarrow \{1, \dots, n\}$ by $\chi(v) = i$, where $v \in V_i$.

We mention here some standard results that we will use immediately.

Lemma 2.1.9.

1. If $A, B \subset V$ are subspaces then $\dim A \cap B + \dim(A + B) = \dim A + \dim B$.
2. Assume that $\{a_i\}_{i=1}^{\infty}$ and $\{b_i\}_{i=1}^{\infty}$ are sequences of real numbers satisfying $a_i \leq b_i$ for each $i \in \mathbb{N}$. If the series $\sum_{i=1}^{\infty} a_i$ and $\sum_{i=1}^{\infty} b_i$ are each convergent and their sums are equal then $a_i = b_i$ for each i .

Lemma 2.1.10. If $A, B \subset V$ are colored subspaces then $A \cap B$ and $A + B$ are colored and $\xi(A + B) + \xi(A \cap B) = \xi(A) + \xi(B)$. If $A \cap B = 0$ then $\xi(A \oplus B) = \xi(A) + \xi(B)$.

Proof. Obviously, $(A \cap B)_i = A_i \cap B_i$ and $A_i + B_i \subset (A + B)_i$, so

$$\begin{aligned}
\dim A + \dim B &= \sum_{i=1}^n \xi_i(A) + \sum_{i=1}^n \xi_i(B) \\
&= \sum_{i=1}^n (\xi_i(A) + \xi_i(B)) \\
&= \sum_{i=1}^n (\dim(A_i) + \dim(B_i)) \\
&= \sum_{i=1}^n (\dim(A_i \cap B_i) + \dim(A_i + B_i)) \\
&\leq \sum_{i=1}^n \xi_i(A \cap B) + \sum_{i=1}^n \xi_i(A + B) \\
&\leq \dim(A \cap B) + \sum_{i=1}^n \xi_i(A + B) \\
&\leq \dim(A \cap B) + \dim(A + B). \\
&= \dim A + \dim B,
\end{aligned}$$

so by lemma 2.1.9 each inequality above is an equality and all of the claims follow. \square

Lemma 2.1.11. If $A \subset V$ is a colored subspace then $(V/A, V_1/A_1, \dots, V_n/A_n)$ is a colored vector space, with $\xi(V/A) = \xi(V) - \xi(A)$. If W is a subspace of V containing A then W is colored if and only if W/A is colored.

Strictly speaking, in the above lemma V_i/A_i should be interpreted as $(V_i + A)/A$, but the isomorphism is clear.

Lemma 2.1.12. *A subset $\mathcal{B} \subset V$ is a colored basis of V if and only if \mathcal{B}_i is a basis of V_i for each i .*

2.2 Colored change of basis

The group $K = GL(V_1) \times \cdots \times GL(V_n) \subset GL(V)$ acts on V , preserving V_i . Since $GL(V_i)$ acts transitively on $V_i \setminus \{0\}$ we see that there are 2^n orbits, parametrized by the power set of $\{1, \dots, n\}$. If $v \in V$ is written as $v = v_1 + \cdots + v_n$, with $v_i \in V_i$, then the corresponding set is $\{i \mid v_i \neq 0\}$.

More generally, K acts on the set of subspaces of V . In fact, if $k \in K$ then $\chi(k \cdot v) = \chi(v)$ for all colored v . Therefore, $\xi(W) = \xi(k \cdot W)$, so W is colored if and only if $k \cdot W$ is colored. We conclude that this action restricts to a signature-preserving action on colored subspaces. We wish to parametrize the orbits of this action—a task that will be easier once we have established a definition, motivated by ξ .

Definition 2.2.1. A *signature* is a function $f : \{1, \dots, n\} \rightarrow \mathbb{Z}^{\geq 0}$. We define the *size* of f by $|f| = \sum_{i=1}^n f(i)$. If f and g are signatures then we say that $f \leq g$ if $f(i) \leq g(i)$ for each i . We also define the signature $f + g$ by the formula $(f + g)(x) = f(x) + g(x)$.

Lemma 2.2.2.

1. *The set of signatures is an Abelian monoid partially ordered by \leq .*
2. *If f, g , and h are signatures then $f \leq g$ if and only if $f + h \leq g + h$.*
3. *If $f \leq g$ are signatures then*
 - (a) $|f| \leq |g|$,
 - (b) $|f| = |g|$ if and only if $f = g$.

Lemma 2.2.3. *If $W \subset V$ is a subspace then*

1. $\xi(W)$ is a signature.
2. W is colored if and only if $|\xi(W)| = \dim W$.
3. If $U \subset W$ then $\xi(U) \leq \xi(W)$.
4. If $U \subset W$ are subspaces satisfying $\xi(U) = \xi(W)$ and W is colored then $U = W$.

5. If $f \leq \xi(W)$ is a signature then there is a colored subspace $U \subset W$ such that $\xi(U) = f$.

Proposition 2.2.4. *The set of orbits of the K -action on the set of subspaces of V is parametrized by signatures $f \leq \xi(V)$. That is, if U and W are colored then they are K -conjugate if and only if $\xi(U) = \xi(W)$. In particular, the set of orbits is finite.*

This statement can be generalized further. If $0 = f_0 < f_1 < \cdots < f_r = \xi(V)$ is a chain of signatures then we can apply lemma 2.2.3 to build a chain of colored subspaces $0 = W_0 \subset \cdots \subset W_r = V$ with $\xi(W_k) = f_k$. K naturally acts on such colored partial flags and we might ask what the orbits are. This is straightforward, summarized in the following proposition, which is an immediate consequence of proposition 2.2.6.

Proposition 2.2.5. *The set of K -orbits on partial flags of colored subspaces is finite and is parametrized by chains $0 = f_0 < f_1 < \cdots < f_r = \xi(V)$ of signatures. That is, two colored partial flags $0 = W_0 \subsetneq \cdots \subsetneq W_{r_1} = V$ and $0 = U_0 \subsetneq \cdots \subsetneq U_{r_2} = V$ are K -conjugate if and only if $r_1 = r_2$ and $\xi(W_k) = \xi(U_k)$ for each k .*

Proposition 2.2.6. *If $\mathcal{A} = \{v_{i,j} \in V_i \mid 1 \leq i \leq n, 1 \leq j \leq \dim V_i\}$ and $\mathcal{B} = \{w_{i,j} \in V_i \mid 1 \leq i \leq n, 1 \leq j \leq \dim V_i\}$ are colored bases of V then the automorphism of V defined by $v_{i,j} \mapsto w_{i,j}$ lies in K .*

Lemma 2.2.7. *Fix a chain $0 = f_0 < \cdots < f_r = \xi(V)$ of signatures and let X_{f_1, \dots, f_r} denote the corresponding partial flag variety. Then X_{f_1, \dots, f_r} is smooth and irreducible. It is isomorphic to the product of partial flag varieties $\prod_{m=1}^n X_m$, where $X_m = \{W_0 \subset \cdots \subset W_{\lambda_1} \subset V_m \mid \dim W_k = f_k(m)\}$, so*

$$\dim X_{f_1, \dots, f_m} = \frac{1}{2} \sum_{m=1}^n \left((\dim V_m)^2 - \sum_{k=1}^r (f_k(m) - f_{k-1}(m))^2 \right).$$

2.3 Colored endomorphisms

Definition 2.3.1. $x \in \text{End}(V)$ is *colored* if xv is colored for every colored $v \in V$.

Proposition 2.3.2. *If $x \in \text{End}(V)$ then the following are equivalent:*

1. x is colored,
2. xW is colored for every colored subspace W ,

3. There is a function $\sigma : \{1, \dots, n\} \rightarrow \{1, \dots, n\}$ such that $xV_i \subset V_{\sigma(i)}$.

Proof.

(3) \implies (1)

This is obvious. In fact, $\chi(xv) = \sigma(\chi(v))$ if both vectors are nonzero.

(2) \implies (1)

This is also immediate, for if v is colored then $\langle v \rangle$ is colored, hence $x\langle v \rangle = \langle xv \rangle$ is colored.

(1) \implies (2)

This follows once we have chosen a colored basis for W .

(1) \implies (3)

This is proved by contrapositive. Fix $i \in \{1, \dots, n\}$. If $xV_i \neq 0$ then there are $v, w \in V_i$ such that xv and xw are nonzero and colored. If $\chi(xv) \neq \chi(xw)$ then $v + w$ is colored but $x(v + w) = xv + xw$ is not. Therefore, x is not colored. \square

If $xV_i \subset V_{\sigma(i)}$ for each i then we may say that $x \in \text{End}(V)$ is σ -colored. The set of all σ -colored endomorphisms of V is a linear space and contains \mathcal{N}_σ , the cone of nilpotent σ -colored endomorphisms of V . Note that the map $x \mapsto \sigma$ is well-defined only to the extent that $xV_i \neq 0$. That is, if $xV_i = 0$ then $\sigma(i)$ may be arbitrary. Otherwise, xV_i is well-defined. This shows that $\mathcal{N}_\sigma \cap \mathcal{N}_{\sigma'}$ is not empty. In fact, the zero transformation is in \mathcal{N}_σ for each σ . If σ is the identity function and x is σ -colored then we say that x is *trivially colored*. Clearly, K is precisely the set of trivially colored automorphisms of V .

The equivalence of (1) and (3) brings us back to quiver representations. Since σ is a function $\{1, \dots, n\} \rightarrow \{1, \dots, n\}$, we can think of σ as a functional graph. That is, the vertices are elements of $\{1, \dots, n\}$ and the edges are precisely the pairs $(i, \sigma(i))$. The proposition shows that x is σ -colored if and only if x can be thought of as a quiver representation of σ with linear spaces V_i and maps $x|_{V_i} : V_i \rightarrow V_{\sigma(i)}$. With this perspective in mind, we can think of a colored subspace W as simply a choice of (W_1, \dots, W_n) , with $W_i \subset V_i$. While we are really concerned with the case where σ is an n -cycle, there are a few results that we can prove if σ is not so specialized.

One nice property possessed by representations of functional graphs as opposed to more general quivers is that there is a clear notion of nilpotency that coincides with our usual understanding of nilpotency. Since each vertex has exactly one outgoing edge we can choose bases for V_i and write the quiver representation as a matrix A . The representation is nilpotent if A is nilpotent.

Lemma 2.3.3. *If $x \in \text{End}(V)$ is σ -colored and $y \in \text{End}(V)$ is τ -colored then xy is $\sigma\tau$ -colored. In particular, x^k is σ^k -colored.*

Proof. $(xy)V_i = x(yV_i) \subset xV_{\tau(i)} \subset V_{\sigma(\tau(i))} = V_{\sigma\tau(i)}$. \square

Proposition 2.3.4. *Assume that W is colored and that $x \in \text{End } V$ is σ -colored, with σ injective. Then*

1. $\ker x$ is colored.
2. $x^{-1}(W)$ is colored.
3. $\xi_{\sigma(m)}(x(W)) = \xi_m(W) - \xi_m(\ker x \cap W)$.
4. $\xi_{\sigma(m)}(W) = \xi_m(x^{-1}(W)) - \xi_m(\ker x)$.

Proof. To prove (2) let $v \in x^{-1}(W)$ and write $v = v_1 + \cdots + v_n$ with $v_i \in V_i$. Then $xv = xv_1 + \cdots + xv_n$ is a decomposition with $xv_i \in V_{\sigma(i)}$. Since W is colored and $xv \in W$ we conclude that $xv_i \in W$, hence $v_i \in x^{-1}(W)$. To prove (1) simply apply (2) to $W = 0$.

Formula (3) is a simple application of the rank-nullity theorem to $x|_{W_m}$. Injectivity of σ is required to ensure that $W_{\sigma(m)} \cap x(W) = x(W_m)$. Formula (4) is just (3) applied to $x^{-1}(W)$. \square

Corollary 2.3.5. *If x is colored and invertible then x is σ -colored for some bijective σ and x^{-1} is σ^{-1} -colored.*

Proof. Let $\dim V_{i_0}$ be maximal. Since x is invertible, $\sigma(i_0)$ is well-defined and $\dim x(V_{i_0}) = \dim V_{i_0}$. But $x(V_{i_0}) \subset V_{\sigma(i_0)}$ and $\dim V_{i_0}$ is maximal, so $\dim V_{\sigma(i_0)} = \dim V_{i_0}$. Inductively, if $V_i \neq 0$ then $\dim V_{\sigma(i)} = \dim V_i$. If $V_i = 0$ then we may choose $\sigma(i) = i$. Invertibility of x guarantees that σ is invertible and the rest follows from (2). \square

Lemma 2.3.6. *If x is σ -colored and $A \subset V$ is an x -stable colored subspace then $x|_A$ is σ -colored relative to (A, A_1, \dots, A_n) . The quotient endomorphism $\bar{x} : V/A \rightarrow V/A$ is well-defined and is σ -colored relative to $(V/A, V_1/A_1, \dots, V_n/A_n)$.*

Lemma 2.3.7. *Let $\sigma \in S_n$, the set of permutations of $\{1, \dots, n\}$, and write $\sigma = \sigma_1 \dots \sigma_m \in S_n$ as a product of disjoint cycles (including one-cycles). The orbits of S_n in $\{1, \dots, n\}$ are in bijection with the cycles σ_i . Under this identification, we can view σ as a partition of $\{1, \dots, n\}$, with parts σ_i . Write $A_i = \bigoplus_{k \in \sigma_i} V_k$. Then*

1. $V = A_1 \oplus \cdots \oplus A_m$,
2. If $1 \leq i \leq m$ then A_i is a colored subspace of V ,
3. If $x \in \mathcal{N}_\sigma$ then A_i is x -stable.

As earlier, set $K = GL(V_1) \times \cdots \times GL(V_n) \subset GL(V)$. The natural action of K on V induces a change-of-basis action in \mathcal{N}_σ . We wish to classify the set of K -orbits on \mathcal{N}_σ . The case $n = 1, \sigma = (1)$ is just the classical parametrization of nilpotents in $\mathfrak{gl}(V) = \text{End}(V)$ by partitions of size $\dim V$. The case $n = 2, \sigma = (12)$ is the parametrization of nilpotents for $U(p, q)$ by signed partitions of signature (p, q) , with $p = \dim V_1, q = \dim V_2$.

Proposition 2.3.8. *If we construct \mathcal{N}_{σ_i} and K_{σ_i} in the obvious way by restriction then the map $x \mapsto (x|_{V_{\sigma_1}}, \dots, x|_{V_{\sigma_n}})$ defines a K -equivariant isomorphism of varieties $\mathcal{N}_\sigma \leftrightarrow \mathcal{N}_{\sigma_1} \times \cdots \times \mathcal{N}_{\sigma_m}$, hence a bijection*

$$K \backslash \mathcal{N}_\sigma \leftrightarrow K_{\sigma_1} \backslash \mathcal{N}_{\sigma_1} \times K_{\sigma_2} \backslash \mathcal{N}_{\sigma_2} \times \cdots \times K_{\sigma_m} \backslash \mathcal{N}_{\sigma_m}.$$

Therefore, to parametrize $K \backslash \mathcal{N}_\sigma$ for an arbitrary permutation σ it is sufficient to parametrize orbits in \mathcal{N}_σ , with σ a cycle. By reordering the V_i (conjugating σ) we may assume that $\sigma(n) = 1$ and $\sigma(i) = i + 1$ for $i \neq n$. For ease of notation, we think of the index set $\{1, \dots, n\}$ (“colors”) as the group $\mathbb{Z}/n\mathbb{Z}$, so $\sigma(i) = i + [1]$. This gives the set the structure of a cyclic graph.

With this assumption, we suppress the dependence on σ and write $\mathcal{N} = \mathcal{N}_\sigma$. When we say that an endomorphism of V is colored, we will assume that it is σ -colored. We call \mathcal{N} the *colored nilpotent cone* of V . As mentioned above, the natural action of K on V induces a change-of-basis action on \mathcal{N} . We wish to classify the set $K \backslash \mathcal{N}$ of K -orbits on \mathcal{N} . That is, if $\mathcal{O}_x = K \cdot x$ is the orbit that contains x , and if $y \in \mathcal{N}$ is arbitrary, we seek simple criteria for determining if $y \in \mathcal{O}_x$.

CHAPTER 3

THE COLORED NILPOTENT CONE

In this section we introduce the concept of a colored Jordan basis for a colored nilpotent endomorphism of V . This immediately leads to the notion of a colored partition. We show that the colored Jordan basis gives a bijection between $K \setminus \mathcal{N}$ and an appropriate set of colored partitions.

3.1 Colored Jordan bases

Definition 3.1.1. If $x \in \text{End}(V)$ and $W \subset V$ is any nonempty subset then we say that W is *x-stable* if $x(W) \subset (W \cup \{0\})$.

Note that if W is a subspace (or any other set containing 0) then W is *x-stable* if and only if $x(W) \subset W$.

Definition 3.1.2. If $x \in \text{End}(V)$ is nilpotent then a *Jordan basis for x* is an *x-stable* basis of V that contains a basis of $\ker x$.

Definition 3.1.3. A *partition* is a function $\lambda : \mathbb{N} \rightarrow \mathbb{Z}^{\geq 0}$ such that $\lambda_i \geq \lambda_{i+1}$ for each i and $\lambda_i = 0$ for some i . We define the *size* of λ by $|\lambda| = \sum_{i=1}^{\infty} \lambda_i$, a sum that is clearly finite, and the *length* of λ by $l(\lambda) = \#\{i \in \mathbb{N} \mid \lambda_i > 0\}$.

Lemma 3.1.4. *A basis \mathcal{B} of V is a Jordan basis for a nilpotent $x \in \text{End}(V)$ if and only if there is a (necessarily unique) partition λ with $|\lambda| = \dim V$ such that the elements of \mathcal{B} can be labeled $v_{i,j}$ with the following properties:*

1. $1 \leq i \leq l(\lambda)$,
2. $1 \leq j \leq \lambda_i$,
3. If $j > 1$ then $xv_{i,j} = v_{i,j-1}$,
4. $xv_{i,1} = 0$,

5. $l(\lambda) = \dim \ker x$.

Proof. Assume that \mathcal{B} is a Jordan basis for x . Since x is nilpotent, there is some $v \in \mathcal{B}$ with $xv = 0$. By cardinality it cannot be the case that $x : \mathcal{B} \rightarrow \mathcal{B} \cup \{0\}$ is surjective, hence $\mathcal{B} \setminus x\mathcal{B}$ is nonempty. Let v_1, \dots, v_r be the elements of $\mathcal{B} \setminus x\mathcal{B}$. Set $\lambda_i = \min\{k \mid x^k v_i = 0\}$. By reordering, we may assume that $\lambda_i \geq \lambda_{i+1}$. Set $v_{i,\lambda_i} = v_i$ and $v_{i,j} = x^{\lambda_i - j} v_{i,\lambda_i}$. Uniqueness of λ and the reverse implication should be clear, for if λ^t is the transpose partition then $\sum_{i=1}^k \lambda_i^t = \dim \ker x^k$. \square

These properties of Jordan bases, as well as several that follow, are classical; the important fact is that we can treat Jordan bases in the usual way, even when we make the additional assumption that the basis is colored. Colored Jordan bases will be central to many of the constructions we present throughout this paper.

Lemma 3.1.5. *Let $x \in \mathcal{N}$ and assume that A, B are x -stable colored subspaces of V with $A \cap B = 0$. If \mathcal{A}, \mathcal{B} are colored Jordan bases for $x|_A$ and $x|_B$, respectively, then $\mathcal{A} \cup \mathcal{B}$ is a colored Jordan basis for $x|_{A \oplus B}$.*

Lemma 3.1.6. *Let \mathcal{B} be a colored Jordan basis for $x \in \mathcal{N}$ and let $\mathcal{A} \subset \mathcal{B}$ be x -stable. If $A = \text{Span } \mathcal{A}$ then*

1. A is x -stable and colored;
2. \mathcal{A} is a colored Jordan basis for $x|_A$.
3. $\mathcal{B} \setminus \mathcal{A}$ is a colored Jordan basis for $x|_{V/A}$. That is, $\{a + A \mid a \in \mathcal{B} \setminus \mathcal{A}\}$ is a colored Jordan basis for $x|_{V/A}$.

3.2 Colored partitions

In the same way that a Jordan basis naturally leads to a partition, a colored Jordan basis naturally leads to a colored partition. Suppose that $x \in \mathcal{N}$ has a Jordan basis $\mathcal{B} = \{v_{i,j}\}$, labeled as in lemma 3.1.4, that is colored. From definition 2.1.8 we have the color function χ , whose codomain we now think of as $\mathbb{Z}/n\mathbb{Z}$. If $0 < j < \lambda_i$ then $\chi(v_{i,j}) = \chi(xv_{i,j+1}) = \chi(v_{i,j+1}) + [1]$. Inductively, then, $\chi(v_{i,j}) = \chi(v_{i,\lambda_i}) + [\lambda_i - j]$. This equation shows that $\chi(v_{i,j})$ is completely determined by the pair (λ, ϵ) , where $\epsilon_i = \chi(v_{i,\lambda_i})$ whenever $1 \leq i \leq l(\lambda)$. Note that if $\lambda_i = \lambda_j$ and $\epsilon_i \neq \epsilon_j$ then we can interchange the roles of i and j , obtaining a new labeling of the same basis. This leads to the following definition.

Definition 3.2.1. A *k-colored partition* is a pair (λ, ϵ) , where λ is a partition and $\epsilon : \mathbb{N} \rightarrow \mathbb{Z}/k\mathbb{Z}$ is a function such that for each $m \in \mathbb{Z}/k\mathbb{Z}$ there are infinitely many i with $\epsilon_i = m$. If $i \in \mathbb{N}$ then the pair (λ_i, ϵ_i) is the *i*th row of (λ, ϵ) and this row has *length* λ_i and *color* ϵ_i . Two *k-colored partitions* are *equivalent* if one can be obtained from the other by permuting rows of the same length. The *size* and *length* of (λ, ϵ) are inherited from λ .

The requirement that there are infinitely many i with $\epsilon_i = m$ is a technical convention whose main consequence is to make certain constructions notationally easier. It also ensures that there are only finitely many equivalence classes of colored partitions of a given size. It also means that in most settings we can disregard the value of ϵ_i if $\lambda_i = 0$, thinking of (λ, ϵ) as a pair of finite tuples. In the construction of the closure order, however, it will be important that for each m there are plenty of integers i with $\lambda_i = 0$ and $\epsilon_i = m$. As n is fixed throughout this paper, we may refer to an *n-colored partition* as simply a “colored partition.”

We visualize a colored partition by drawing the (left-justified) Young diagram for λ and labeling the rightmost box in row i with ϵ_i . Labels then increase by 1 (mod n) from right to left across rows, so the color of the box in row i (counting from the top) and column j (counting from the left) is given by $\epsilon_i + [\lambda_i - j]$. It is clear that the construction works in reverse: each diagram constructed in this way comes from a unique colored partition. Two of these *colored Young diagrams* are equivalent if one can be obtained from the other by reordering rows of the same length.

Definition 3.2.2. If (λ, ϵ) is a colored partition then the *signature* of (λ, ϵ) is the function $\xi(\lambda, \epsilon) : \mathbb{Z}/n\mathbb{Z} \rightarrow \mathbb{Z}^{\geq 0}$ defined by

$$\xi_m(\lambda, \epsilon) = \#\{(i, j) \mid 1 \leq j \leq \lambda_i, \epsilon_i + [\lambda_i - j] = m\}.$$

For a fixed signature f let \mathcal{P}_f denote the (finite) set of equivalence classes of colored partitions of signature f . When writing it down, we may think of $\xi(\lambda, \epsilon)$ as the tuple $(\xi_0(\lambda, \epsilon), \dots, \xi_{n-1}(\lambda, \epsilon))$.

Definition 3.2.3. Let (λ, ϵ) be a colored partition with $\xi(\lambda, \epsilon) = \xi(V)$. We say that a basis $\mathcal{B} = \{v_{i,j}\}$ of V is of type (λ, ϵ) if for each $v_{i,j} \in \mathcal{B}$ we have

1. $1 \leq i \leq l(\lambda)$,
2. $1 \leq j \leq \lambda_i$,
3. $\chi(v_{i,j}) = \epsilon_i + [\lambda_i - j]$.

1	0	2	1	0
0	2	1	0	
2	1	0	2	
2	1			
1	0			
1				

Figure 3.1. A 3-colored partition of signature $(6, 7, 5)$. In this example we have $\lambda = (5, 4, 4, 2, 2, 1)$ and $\epsilon = (0, 0, 2, 1, 0, 1)$.

Strictly speaking, it is the *labeled set* \mathcal{B} that is of type (λ, ϵ) . However, the terminology given has the advantage of brevity. The colored Young diagram is a convenient way to visualize \mathcal{B} . The coordinate (i, j) gives a color-preserving bijection between the boxes of the diagram and the elements of \mathcal{B} , so we may think of the boxes as elements of \mathcal{B} . If \mathcal{B} happens to be a Jordan basis of $x \in \mathcal{N}$ then we can visualize the action of x as sending each box to the one immediately to its left. Boxes in the leftmost column are sent to zero.

Lemma 3.2.4. *If (λ, ϵ) is a colored partition of signature $\xi(V)$ then*

1. *If \mathcal{B} is any colored basis of V then the elements of \mathcal{B} can be labeled $v_{i,j}$ to make $\mathcal{B} = \{v_{i,j}\}$ a basis of type (λ, ϵ) ;*
2. *If $\mathcal{B} = \{v_{i,j}\}$ is a basis of type (λ, ϵ) then \mathcal{B} is a colored Jordan basis for x , where x is the colored endomorphism of V defined by*

$$xv_{i,j} = \begin{cases} 0 & j = 1, \\ v_{i,j-1} & j > 1; \end{cases}$$

3. If x is defined as in (2) and we define $\mathcal{O}_{\lambda,\epsilon} = \mathcal{O}_x$ then $(\lambda, \epsilon) \mapsto \mathcal{O}_{\lambda,\epsilon}$ is a well-defined map from $\mathcal{P}_{\xi(V)}$ into $K \setminus \mathcal{N}$.

We will soon see that the map $(\lambda, \epsilon) \mapsto \mathcal{O}_{\lambda,\epsilon} : \mathcal{P}_{\xi(V)} \rightarrow K \setminus \mathcal{N}$ is a bijection. For now, we observe that the boxes in the leftmost column of the colored Young diagram form a basis of $\ker x$. Similarly, the boxes in the first k columns form a basis of $\ker x^k$. We define $s_k(x) = \xi(\ker x^k)$, the signature of the first k columns of the colored Young diagram corresponding to x . The signatures s_k are important combinatorial data that will be seen to completely characterize orbits and their closures.

More generally, let $\lambda : \mathbb{N} \rightarrow \mathbb{Z}^{\geq 0}$ be any function with finite support and let ϵ be as in the definition above. We can similarly visualize (λ, ϵ) , though the rows may not be in descending order and there may be gaps to indicate i with $\lambda_i = 0$. The group of permutations of \mathbb{N} acts on the set of such pairs (λ, ϵ) by $\sigma \cdot (\lambda, \epsilon) = (\lambda \circ \sigma^{-1}, \epsilon \circ \sigma^{-1})$. Each orbit of this action contains a colored partition and if λ and $\lambda \circ \sigma$ are both partitions then $\lambda \circ \sigma = \lambda$. In other words, if two colored partitions are in the same orbit then one can be transformed into the other by reordering rows of the same length. Therefore, each orbit contains a unique equivalence class of colored partitions.

While there is no need to introduce this level of generality here, certain constructions later are simpler in this context. They will begin with a colored partition and produce an object that may not be a colored partition but is equivalent to a colored partition. The description above gives us a well-defined (up to equivalence) way of building a colored partition from such an object.

Lemma 3.2.5. *If (λ, ϵ) is a colored partition and $m \in \mathbb{Z}/n\mathbb{Z}$ then*

$$\xi_m(\lambda, \epsilon) = \sum_{i=1}^{\infty} \left\lfloor \frac{\lambda_i - \langle m - \epsilon_i \rangle}{n} \right\rfloor,$$

a formula that is invariant under the action of each permutation σ of \mathbb{N} .

3.3 The colored Jordan normal form

Definition 3.3.1. Fix $(v, x) \in V \times \text{End}(V)$. We write $\mathbb{F}[x](v)$ to denote the smallest x -stable subspace of V containing v . If $x^k v = 0$ for some $k \in \mathbb{Z}^{\geq 0}$, let $d_x(v)$ be the smallest such k .

Lemma 3.3.2. *Let $(v, x) \in V$ satisfy $x^k v = 0$ for some $k \in \mathbb{N}$. If we set*

$$\mathcal{B}_{v,x} = \{x^k v \mid 0 \leq k < d_x(v)\}$$

then

1. $\mathcal{B}_{v,x}$ is a Jordan basis for $x|_{\mathbb{F}[x](v)}$, so $d_x(v) = \dim \mathbb{F}[x](v) \leq \dim V$.
2. $\mathbb{F}[x](w) \subset \mathbb{F}[x](v)$ if and only if $w \in \mathbb{F}[x](v)$.
3. The x -stable subspaces of $\mathbb{F}[x](v)$ are precisely

$$x^i \mathbb{F}[x](v) = \mathbb{F}[x](x^i v) = \ker(x^{d_x(v)-i}) \cap \mathbb{F}[x](v), 0 \leq i \leq d_x(v),$$

with $\dim \mathbb{F}[x](x^i v) = d_x(v) - i$.

4. If v is colored then $\mathcal{B}_{v,x}$ is colored, so $\mathbb{F}[x](v)$ is colored.
5. If $\mathbb{F}[x](v)$ is colored then there is a colored vector w such that $\mathbb{F}[x](w) = \mathbb{F}[x](v)$. If w' is another such vector then $\chi(w) = \chi(w')$.
6. If $w \in \mathbb{F}[x](v)$ then there exists $v' \in V$ such that $\mathbb{F}[x](v') = \mathbb{F}[x](v)$ and $w \in \mathcal{B}_{v',x}$. If $\mathbb{F}[x](v)$ is colored and w is colored then we may choose v' to be colored.

Proof. Since v and x are fixed, we will set $d = d_x(v)$ throughout the proof to simplify notation.

1. It is clear that $\mathcal{B}_{v,x}$ must be contained in any x -stable subspace of V containing v . The set $\mathcal{B}_{v,x}$ is x -stable because $x^d v = 0$, so its span must be $\mathbb{F}[x](v)$. We prove linear independence by induction on d . If $\sum_{j=0}^{d-1} a_j x^j v = 0$ then

$$0 = x \sum_{j=0}^{d-1} a_j x^j v = \sum_{j=0}^{d-2} a_j x^j (xv).$$

By induction, we must have $a_j = 0$ for each $j < d - 1$. Therefore, $a_{d-1} x^{d-1} v = 0$, hence $a_{d-1} = 0$. The rest follows immediately.

2. This is obvious.

3. From (1) the given spaces are x -stable and $\dim \mathbb{F}[x](x^i v) = d - i$. Let $w \in \mathbb{F}[x](v)$ with $d' = d_x(w)$. Write $w = \sum_{j=1}^d a_j x^{d-j} v$. Then

$$0 = x^{d'} w = \sum_{j=1}^d a_j x^{d+d'-j} v = \sum_{j=d'+1}^d a_j x^{d+d'-j} v.$$

Linear independence implies that $a_{d'+1} = \cdots = a_d = 0$, so

$$w = \sum_{j=1}^{d'} a_j x^{d-j} v = \sum_{j=1}^{d'} a_j x^{d'-j} (x^{d-d'} v).$$

Therefore, $w \in \mathbb{F}[x](x^{d-d'} v)$. Since $\dim \mathbb{F}[x](x^{d-d'} v) = d_x(w)$ we must conclude that $\mathbb{F}[x](x^{d-d'} v) = \mathbb{F}[x](w)$.

4. $x^i v \in V_{\chi(v)+[i]}$.
5. Decompose $v = v_1 + \cdots + v_n$ with $v_m \in V_m$. There must be some r such that $d_x(v_r) \geq d_x(v)$. Since $\mathbb{F}[x](v)$ is colored, we may set $w = v_r \in \mathbb{F}[x](v)$. Then $d_x(v_r) = \dim \mathbb{F}[x](v_r) \leq \dim \mathbb{F}[x](v) = d_x(v)$, hence $d_x(v_r) = d_x(v)$ and we apply (3). Uniqueness of r follows immediately from the fact that $\ker x|_{\mathbb{F}[x](v)}$ is a one-dimensional colored subspace.
6. If $w = \sum_{j=1}^{d'} a_j x^{d'-j} (x^{d-d'} v)$ as in (3), set $v' = \sum_{j=1}^{d'} a_j x^{d'-j} v$. To prove the last claim we first observe that, since $\mathbb{F}[x](v)$ is colored, we may assume that v is colored. In the above expression for w , the indices j such that $a_j \neq 0$ must all be congruent modulo n . This congruence must also hold in the expression for v' , so v' is colored. \square

Proposition 3.3.3. *Each element of \mathcal{N} admits a colored Jordan basis.*

Proof. Fix $x \in \mathcal{N}$ and choose $v \in V$ such that $d_x(v)$ is maximal. If we decompose $v = v_0 + \cdots + v_{n-1}$ then there exists $m \in \mathbb{Z}/n\mathbb{Z}$ such that $d_x(v_m) = d_x(v)$. By relabeling, we may assume that v is colored, so $W = \mathbb{F}[x](v)$ is colored and x -stable with a colored Jordan basis $\mathcal{B}_{v,x}$.

Inductively assume that $W \subset V$ is an x -stable colored subspace that admits a colored Jordan basis. That is, there exist colored vectors v_1, \dots, v_r such that $\bigsqcup \mathcal{B}_{v_i,x}$ is a basis of W . Assume further that if $x : V/W \rightarrow V/W$ is the map induced by x then $d_x(v_i) \geq d_{\bar{x}}(\bar{w})$ for each $\bar{w} \in V/W$. Note that clearly $d_x(w) \geq d_{\bar{x}}(\bar{w})$.

Let w be a colored vector with $d_{\bar{x}}(\bar{w})$ maximal. Then $W \cap \mathbb{F}[x](w)$ is an x -stable colored subspace of $\mathbb{F}[x](w)$, hence $W \cap \mathbb{F}[x](w) = \mathbb{F}[x](x^k w)$ for some $k \geq 0$. Write $x^k w = \sum u_i$, with $u_i \in \mathbb{F}[x](v_i)$. By applying (6) from lemma 3.3.2 to $u_i \in \mathbb{F}[x](v_i)$ we may write $x^k w = \sum_i x^{k_i} v_i$. Now, $d_x(v_i) - k_i = d_x(x^{k_i} v_i) \leq d_x(x^k w) = d_x(w) - k$ and we have $k_i - k \geq d_x(v_i) - d_x(w) \geq 0$. Therefore, we can set $v_{r+1} = w - \sum_i x^{k_i - k} v_i$. Then $W + \mathbb{F}[x](v_{r+1}) = W + \mathbb{F}[x](w)$ and $d_x(v_{r+1}) = d_{\bar{x}}(\bar{w})$. Furthermore, the construction ensures that v_{r+1} is colored, so $(\bigsqcup \mathcal{B}_{v_i, x}) \sqcup \mathcal{B}_{v_{r+1}, x}$ is a colored Jordan basis for $W \oplus \mathbb{F}[x](w)$ and $d_x(v_i) \geq d_{\bar{x}}(\bar{w})$ for each $\bar{w} \in V/(W \oplus \mathbb{F}[x](w))$, which completes the induction. \square

If x has a colored Jordan basis of type (λ, ϵ) then we may refer to (the equivalence class of) (λ, ϵ) as the *colored Jordan type* of x . We will shortly see that this is well-defined. With this terminology in mind, the proposition and its proof give us the following:

Corollary 3.3.4. *If $v_0 \in V$ is colored and satisfies $d_x(v_0) \geq d_x(v)$ for each $v \in V$ then $W_0 = \mathbb{F}[x](v_0)$ has an x -stable colored complement W and $x|_W$ has the same colored Jordan type as $x|_{V/W_0}$.*

Theorem 3.3.5. *The map $(\lambda, \epsilon) \mapsto \mathcal{O}_{\lambda, \epsilon} : \mathcal{P}_{\xi(V)} \rightarrow K \backslash \mathcal{N}$ defined in lemma 3.2.4 is a bijection. That is, if $x \in \mathcal{N}$ has a colored Jordan basis of type (λ, ϵ) and $y \in \mathcal{O}_x$ has a colored Jordan basis of type (α, β) then any (λ, ϵ) and (α, β) are equivalent. Each colored partition of signature $\xi(V)$ is the type of a colored Jordan basis for some $x \in \mathcal{N}$. Moreover, if $x, y \in \mathcal{N}$ then $\mathcal{O}_y = \mathcal{O}_x$ if and only if $s_k(x) = s_k(y)$ for each $k \in \mathbb{N}$.*

Proof. Surjectivity is the content of proposition 3.3.3, so we only need to show injectivity. If $h \in K$ and $k \in \mathbb{N}$ then

$$\begin{aligned} s_k(h \cdot x) &= \xi(\ker(h \cdot x)^k) \\ &= \xi(\ker(h \cdot x^k)) \\ &= \xi(h \cdot \ker x^k) \\ &= \xi(\ker x^k) \\ &= s_k(x). \end{aligned}$$

Therefore, if $y \in \mathcal{O}_x$ then $s_k(x) = s_k(y)$ for each $k \in \mathbb{N}$.

Now, if $s_k(x) = s_k(y)$ and we draw the colored Young diagram with the columns aligned on the left then the number of boxes in column k is equal to $\dim(\ker x^k) - \dim \ker x^{k-1}$. For a fixed color m , the number of boxes of color m in column k is precisely

$s_k(x)(m) - s_{k-1}(x)(m)$. If there is a box of color m in column $k > 1$ then the box immediately to the left must be of color $m + [1]$, so inductively the rows are uniquely determined, up to reordering entire rows. Therefore, the colored Jordan types of x and y are equivalent, so the map is injective.

Finally, if the colored Jordan types of x and y are equivalent then $\mathcal{O}_x = \mathcal{O}_y$ by (3) in lemma 3.2.4. \square

Definition 3.3.6. If $x \in \mathcal{N}$ has colored Jordan type (λ, ϵ) then $s_k(\lambda, \epsilon) = s_k(x)$.

Corollary 3.3.7. *The following are equivalent:*

1. (λ, ϵ) and (α, β) are equivalent;
2. $\mathcal{O}_{\lambda, \epsilon} = \mathcal{O}_{\alpha, \beta}$;
3. $s_k(\lambda, \epsilon) = s_k(\alpha, \beta)$.

We could, just as easily, have considered $\bar{s}_k(x) = \xi(V/\text{im } x^k)$. This is the signature of the rightmost k columns of the diagram for x , if it has been right-justified. The following lemma suggests (and later work will confirm) that many results based on s_k can be reformulated in terms of \bar{s}_k as convenience dictates. Note that the right-hand side of the equation below is independent of x .

Lemma 3.3.8. *If $x \in \mathcal{N}$, $k \in \mathbb{Z}^{\geq 0}$, and $m \in \mathbb{Z}/n\mathbb{Z}$ then*

$$\bar{s}_k(x)(m) - s_k(x)(m - [k]) = \dim V_m - \dim V_{m-[k]}.$$

Proof. By definition,

$$\begin{aligned} \bar{s}_k(x)(m) &= \xi(V/\text{im } x^k)(m) \\ &= \xi(V)(m) - \xi(\text{im } x^k)(m) \\ &= \dim V_m - \dim(V_m \cap \text{im } x^k). \end{aligned}$$

Since $\text{im } x^k \cap V_m = \text{im}(x^k|_{V_{m-[k]}})$, the result follows by applying the rank-nullity theorem to $x^k|_{V_{m-[k]}} : V_{m-[k]} \rightarrow V_m$. \square

Lemma 3.3.9. *(Classification of colored Jordan bases)*

1. *If \mathcal{B} is a colored Jordan basis for x and $k \in K$ then $k\mathcal{B}$ is a colored Jordan basis for $k \cdot x$.*

2. If $\mathcal{B} = \{v_{i,j}\}$ and $\mathcal{B}' = \{w_{i,j}\}$ are colored Jordan bases for x , each of type (λ, ϵ) , then there is a unique $k \in K$ such that $kv_{i,j} = w_{i,j}$ and $xk = kx$. In other words, the set of labeled colored Jordan bases for x is parametrized by $\{k \in K \mid k \cdot x = x\}$.

If $n = 1$ then ϵ is trivial, so we naturally obtain the classical parametrization of nilpotents by partitions. In this case, the signature of a partition is the same as its size. If $n = 2$ then it is customary to use $+$ and $-$ as colors, rather than 0 and 1, respectively, hence the terminology “signed partition.” The signature of a signed partition is the pair (p, q) , where p is the number of boxes containing a $+$ sign and q is the number of boxes containing a $-$ sign.

-	+	-	+	-
+	-	+	-	+
-	+	-		
+	-			
+	-			
-				

Figure 3.2. A signed partition of signature $(8, 10)$. This example is $\lambda = (5, 5, 3, 2, 2, 1)$ and $\epsilon = (-, +, -, -, -, -)$.

CHAPTER 4

THE ENHANCED COLORED NILPOTENT CONE

Since the action of K on V preserves $\tilde{V} = \bigcup_{i \in \mathbb{Z}/n\mathbb{Z}} V_i$, we have a diagonal action of K on the *enhanced* colored nilpotent cone $\tilde{V} \times \mathcal{N}$. We have seen that $K \backslash \mathcal{N}$ is finite and is parametrized by $\mathcal{P}_{\xi(V)}$. We will show that this enhanced diagonal action also yields finitely many orbits and we will describe a simple generalization of $\mathcal{P}_{\xi(V)}$ that parametrizes these orbits. As was discussed earlier, the case $n = 1$ was proved in [7] and [1], with orbits parametrized by bipartitions. The procedures and notation used in [1] prove to generalize particularly well in this context, so whenever possible we use them as a model in this exposition.

4.1 Marked colored partitions

Definition 4.1.1. If (λ, ϵ) is a colored partition and k is a positive integer then

1. A *marking* of λ is a function $\mu : \mathbb{N} \rightarrow \mathbb{Z}$ such that $\mu_i \leq \lambda_i$ for each i . The pair (λ, μ) is a *marked partition*. For convenience we will frequently make use of $\nu = \nu(\lambda, \mu) = \lambda - \mu \geq 0$.
2. The triple (λ, ϵ, μ) is a *marked colored partition*.
3. If (λ, μ) is a marked partition such that $0 \leq \mu_{i+1} \leq \mu_i$ and $\nu_{i+1} \leq \nu_i$ for each i then (λ, μ) is a *bipartition* and (λ, ϵ, μ) is a *colored bipartition*.
4. If $-k < \mu_i$ for all i and $\mu_j < \mu_i + k$ and $\nu_j < \nu_i + k$ for each $i < j$ then (λ, μ) is a *k-bipartition*.
5. (λ, ϵ, μ) is a *striped k-bipartition* if (λ, μ) is a *k-bipartition* and $\epsilon_i + \nu_i \equiv \epsilon_j + \nu_j \pmod{k}$ for each i, j .
6. If (λ, ϵ, μ) satisfies $-k < \mu_i$ for all i then (λ, ϵ, μ) is a *generalized striped k-bipartition* if $\mu_j < \mu_i + k$ and $\nu_j < \nu_i + k$ for each pair $i < j$ such that $\epsilon_i + \nu_i \equiv \epsilon_j + \nu_j \pmod{k}$.

If $n = 1$ then ϵ is trivial, so when it is convenient we may simply express (λ, ϵ, μ) as the marked partition (λ, μ) . We visualize (λ, ϵ, μ) by drawing the colored Young diagram for (λ, ϵ) and marking the wall between boxes $\mu_i, \mu_i + 1$ in row i . If $\mu_i \leq 0$ then we mark the leftmost wall in the row. As in the previous section, we think of the boxes in the diagram as elements of a colored Jordan basis $\mathcal{B} = \{v_{i,j} \mid 1 \leq j \leq \lambda_i\}$ for some $x \in \mathcal{O}_{\lambda, \epsilon}$. We may refer to (λ, ϵ) as the *shape* of (λ, ϵ, μ) .

It is usually convenient to draw the marked colored Young diagram with the marks aligned. That is, the rows are shifted left or right as necessary so that the marks form a single vertical line. If $\mu_i < 0$ then we draw the left end of the row $|\mu_i|$ positions to the *right* of the mark. The marking divides the colored Young diagram into two sub-diagrams. If $\mu \geq 0$ then the sub-diagram on the left of the marks is the colored diagram corresponding to $(\mu, \epsilon + [\nu])$, while the diagram on the right corresponds to (ν, ϵ) . Finally, (λ, ϵ, μ) is a colored bipartition if and only if $(\mu, \epsilon + [\nu])$ and (ν, ϵ) are each colored partitions.

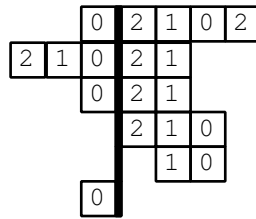

Figure 4.1. A striped 3-bipartition. This example is defined by $\lambda = (5, 5, 3, 3, 2, 1)$, $\epsilon = (2, 1, 1, 0, 0, 0)$, $\mu = (1, 3, 1, 0, -1, 1)$. Notice that, on each side of the diagram, each increase in length (from top to bottom) is less than 3.

Note that each striped k -bipartition is a generalized striped k -bipartition and each bipartition is a k -bipartition. More generally, if $l > k$ then each k -bipartition is automatically an l -bipartition. Furthermore, if $k = 1$ then $\mu_i \geq 0$ and $\mu_{i+1} < \mu_i + 1$, so $\mu_{i+1} \leq \mu_i$. Similarly, $\nu_{i+1} < \nu_i + k$ implies that $\nu_{i+1} \leq \nu_i$. That is, a 1-bipartition is just a bipartition. In this sense, a k -bipartition is a deformation of a bipartition. The following lemma makes this deformation idea precise.

Lemma 4.1.2. *If (λ, μ) is a marked partition, define the marking $\tilde{\mu}$ of λ by*

$$\tilde{\mu}_i = \max(\{\mu_j \mid j \geq i\} \cup \{\lambda_i - \lambda_j + \mu_j \mid j < i\} \cup \{0\}).$$

1. $(\lambda, \tilde{\mu})$ is a bipartition satisfying $\tilde{\mu} \geq \mu$.
2. If (λ, δ) is another bipartition satisfying $\delta \geq \mu$ then $\tilde{\mu} \leq \delta$.
3. (λ, μ) is a striped k -bipartition if and only if $0 \leq \tilde{\mu} - \mu < k$.

Proof.

1. It is obvious that $\tilde{\mu} \geq \mu$. Now, for fixed i we have

$$\begin{aligned}\tilde{\mu}_i &= \max(\{\mu_j \mid j \geq i+1\} \cup \{\lambda_i - \lambda_k + \mu_k \mid k < i\} \\ &\quad \cup \{\mu_i\} \cup \{0\}) \\ \tilde{\mu}_{i+1} &= \max(\{\mu_j \mid j \geq i+1\} \cup \{\lambda_{i+1} - \lambda_k + \mu_k \mid k < i\} \\ &\quad \cup \{\mu_i - \lambda_i + \lambda_{i+1}\} \cup \{0\}).\end{aligned}$$

These decompositions make it clear that for each element in the set corresponding to $\tilde{\mu}_{i+1}$ there is an element of the set corresponding to $\tilde{\mu}_i$ that is at least as large. Therefore, $\tilde{\mu}_i \geq \tilde{\mu}_{i+1}$. A similar decomposition shows that $\lambda_i - \tilde{\mu}_i \geq \lambda_{i+1} - \tilde{\mu}_{i+1}$:

$$\begin{aligned}\lambda_i - \tilde{\mu}_i &= \min(\{\lambda_i - \mu_j \mid j \geq i+1\} \cup \{\lambda_k - \mu_k \mid k < i\} \\ &\quad \cup \{\lambda_i - \mu_i\} \cup \{\lambda_i\}) \\ \lambda_{i+1} - \tilde{\mu}_{i+1} &= \min(\{\lambda_{i+1} - \mu_j \mid j \geq i+1\} \cup \{\lambda_k - \mu_k \mid k < i\} \\ &\quad \cup \{\lambda_i - \mu_i\} \cup \{\lambda_{i+1}\}).\end{aligned}$$

2. Let (λ, δ) be a bipartition such that $\delta \geq \mu$. If $j \geq i$ then $\delta_i \geq \delta_j \geq \mu_j$. Similarly, if $j < i$ then $\delta_i = \lambda_i - (\lambda_i - \delta_i) \geq \lambda_i - (\lambda_j - \delta_j) \geq \lambda_i - \lambda_j + \mu_j = \lambda_i - \lambda_j + \mu_j$. Therefore, $\delta \geq \max(\{\mu_j \mid j \geq i\} \cup \{\lambda_i - \lambda_j + \mu_j \mid j < i\}) = \tilde{\mu}_i$
3. Assume first that $0 \leq \tilde{\mu} - \mu < k$. Let $i < j$. Then $\mu_j < \tilde{\mu}_j \leq \tilde{\mu}_i < \mu_i + k$ and $\lambda_j - \mu_j = \lambda_j - \mu_j < \lambda_j + k - \tilde{\mu}_j \leq k + \lambda_i - \tilde{\mu}_i \leq k + \lambda_i - \mu_i = \lambda_i - \mu_i + k$, so (λ, μ) is an n -bipartition. Conversely, assume that (λ, μ) is an n -bipartition. If $j < i$ then $\lambda_i - \lambda_j + \mu_j = \lambda_i + k - \lambda_i + \mu_i < k + \mu_i$. If $j > i$ then $\mu_j < \mu_i + k$. Therefore, $\tilde{\mu}_i < \mu_i + k$ and we conclude that $0 \leq \tilde{\mu} - \mu < k$. \square

Definition 4.1.3. If (λ, μ) is a marked partition and

$$\tilde{\mu}_i = \max(\{\mu_j \mid j \geq i\} \cup \{\lambda_i - \lambda_j + \mu_j \mid j < i\} \cup \{0\})$$

then $(\lambda, \tilde{\mu})$ is the *minimal bipartition* associated to (λ, μ) .

Proposition 4.1.4. *Let (λ, ϵ, μ) be a marked colored partition. Then (λ, ϵ, μ) is a minimal bipartition if and only if for each i there is a j such that $\epsilon_j + \lambda_j - \mu_j = 0$ and either*

1. $\lambda_j \leq \lambda_i$ and $\mu_j = \mu_i$ or
2. $\lambda_j \geq \lambda_i$ and $\lambda_i - \mu_i = \lambda_j - \mu_j$.

Note that if $\lambda_j = \lambda_i$ then the two conditions are equivalent.

As usual, we view two marked colored partitions as equivalent if one can be transformed into the other by reordering rows, along with corresponding marks. It is a simple exercise to show that if (λ, ϵ, μ) and (α, β, γ) are row equivalent and one of them is a striped n -bipartition then so is the other. Let \mathcal{P}_f^m denote the set of equivalence classes of marked colored partitions of signature f . Let $\mathcal{Q}_f \subset \mathcal{P}_f^m$ denote the (clearly finite) subset consisting of striped n -bipartitions. It will soon be important to consider a slightly stronger equivalence relation on marked colored partitions, so when clarity is required we may say “row-equivalence” to refer to the above relation.

It is worth digressing here for a brief discussion of notation. It is common to define a bipartition as a pair $(\mu; \nu)$ of partitions and then define $\lambda = \mu + \nu$. This is done, for example, in [1]. To be consistent with this choice of notation, we could define a colored bipartition to be a pair $((\mu, \beta); (\nu, \epsilon))$ of colored partitions such that $\beta = \epsilon + [\nu]$. Alternatively, we could choose to denote this (μ, ν, ϵ) . However, we find the notation in the definition, which emphasizes the underlying partition λ , to be more convenient for our purposes here.

Our parametrization of $K \backslash (\tilde{V} \times \mathcal{N})$ will essentially be in terms of a set of marked colored partitions. To each element of $\mathcal{P}_{\xi(V)}$ there corresponds an orbit in $K \backslash (V \times \mathcal{N})$. The set of marked colored partitions of signature $\xi(V)$ is infinite, but we will see that the set of orbits corresponding to marked colored partitions is finite, so it is clear from the outset that there are many markings of a fixed colored partition that must be considered equivalent for the purposes of this parametrization. The construction we give will make it clear that if $\mu_i \leq 0$ then the precise value of μ_i is irrelevant. Thus, we can consider (λ, ϵ, μ) and (α, β, γ) equivalent if there is a permutation σ of \mathbb{N} such that $\alpha = \lambda \circ \sigma$, $\beta = \epsilon \circ \sigma$, and $\gamma_i = (\mu \circ \sigma)_i$ whenever $\gamma_i > 0$ or $(\mu \circ \sigma)_i > 0$. In other words, we are completely disregarding the value of μ_i if $\mu_i \leq 0$. Let $\tilde{\mathcal{P}}_f$ denote the set of classes under this equivalence and let $\tilde{\mathcal{Q}}_f$ be the subset whose classes each contain at least one striped n -bipartition.

If a signature f is fixed then $\tilde{\mathcal{P}}_f$ and $\tilde{\mathcal{Q}}_f$ are finite. This is because from each class in $\tilde{\mathcal{P}}_f$ we can always select an element (λ, ϵ, μ) with $\mu \geq 0$. In fact, this element is unique up to row equivalence. However, certain calculations are easier if we select a different representative. We will never actually use representatives with $\mu_i \leq -n$ in this exposition, but the fact that each class is rich with representatives keeps notation simple and ensures a framework for easily stating and proving the theorems in this section. We observe here that each class in $\tilde{\mathcal{P}}_f$ is a union of classes in \mathcal{P}_f^m .

We now explore the extent to which two striped n -bipartitions (λ, ϵ, μ) and (α, β, γ) can lie in different classes in $\tilde{\mathcal{Q}}_f$. By reordering we may assume $\alpha = \lambda$, $\beta = \epsilon$, and that if $\mu_i \neq \gamma_i$ then $\mu_i \leq 0$ and $\gamma_i \leq 0$. If $\mu_{i_0} > 0$ for some i_0 and $\mu_i \leq 0$ then $\epsilon_i + [\lambda_i - \mu_i] = \epsilon_{i_0} + [\lambda_{i_0} - \mu_{i_0}]$, so $[\mu_i] = \epsilon_i - \epsilon_{i_0} + [\lambda_i - \lambda_{i_0} + \mu_{i_0}]$ and $-n < \mu_i \leq 0$. But this uniquely determines μ_i . Therefore, if $\mu_i > 0$ for some i then there is only one equivalence class of striped n -bipartitions in each element of $\tilde{\mathcal{Q}}_f$. If, however, $\mu_i \leq 0$ for each i then the same calculation shows that μ is fixed once we have chosen a value of μ_1 . Thus, there are exactly n (row equivalence classes of) striped n -bipartitions (λ, ϵ, μ) satisfying $\mu \leq 0$, determined by $m = \epsilon_1 + [\lambda_1 - \mu_1]$.

Definition 4.1.5. Let (λ, ϵ, μ) be a marked colored partition and let $(\lambda, \tilde{\mu})$ be the minimal bipartition corresponding to (λ, μ) . Fix $m \in \mathbb{Z}/n\mathbb{Z}$. For each i let

$$\delta_i = \max\{k \in \mathbb{Z} \mid k \leq \mu_i, \epsilon_i + [\lambda_i - k] = m\}.$$

We define $\rho_m : \mathcal{P}_f^m \rightarrow \mathcal{P}_f^m$ by $\rho_m(\lambda, \epsilon, \mu) = (\lambda, \epsilon, \delta)$ and $\bar{\rho} : \mathcal{P}_f^m \rightarrow \mathcal{P}_f^m$ by $\bar{\rho}(\lambda, \epsilon, \mu) = (\lambda, \epsilon, \tilde{\mu})$.

It is clear that ρ_m and $\bar{\rho}$ are simply processes that produce a new marking of a given colored partition. In terms of our diagrams (with marks aligned), ρ_m modifies the picture by shifting each row to the right just until each column consists of a single color and the column immediately to the left of the marks has color m . On the other hand, $\bar{\rho}$ shifts rows to the left just far enough to produce a bipartition. Note that $\rho_m \circ \rho_m = \rho_m$ and that $(\rho_m \circ \bar{\rho})(\lambda, \epsilon, \mu) = (\lambda, \epsilon, \mu)$ if and only if (λ, ϵ, μ) is a striped n -bipartition and $\epsilon + [\lambda - \mu] = m$. With this notation, lemma 4.1.2 can be restated as follows:

Lemma 4.1.6. *A marked colored partition (λ, ϵ, μ) is a striped n -bipartition if and only if there is a color m satisfying $\epsilon + [\lambda - \mu] = m$ and $(\lambda, \epsilon, \mu) = \rho_m(\lambda, \epsilon, \delta)$ for some colored bipartition $(\lambda, \epsilon, \delta)$. Moreover, among such markings δ of λ there is a unique minimal*

marking $\tilde{\mu}$ of λ such that $\bar{\rho}(\lambda, \epsilon, \mu) = (\lambda, \epsilon, \tilde{\mu})$ is a colored bipartition satisfying $\tilde{\mu} \leq \delta$ for each i .

In other words, ρ_m and $\bar{\rho}$ are inverse bijections between the set of striped n -bipartitions (and their corresponding equivalence classes) and the corresponding set of minimal colored bipartitions. We will employ either of these sets as convenience dictates.

4.2 Normal bases

We now show how to construct an enhanced K -orbit from a marked colored partition.

Definition 4.2.1. Let (λ, ϵ, μ) be a marked colored partition and let $x \in \mathcal{O}_{\lambda, \epsilon}$. Let $\mathcal{B} = \{v_{i,j}\}$ be a colored Jordan basis for x of type (λ, ϵ) . Extend this notation, setting $v_{i,j} = 0$ if $j \leq 0$. Define $\Psi(\lambda, \epsilon, \mu) = \mathcal{O}_{v,x}$, where $v = \sum_{i=1}^{l(\lambda)} v_{i,\mu_i}$.

It should be clear that $\Psi : \tilde{\mathcal{P}}_{\xi(V)}^m \rightarrow V \times \mathcal{N}$ is well-defined. As was mentioned above, $\tilde{\mathcal{P}}_{\xi(V)}^m$ is finite. Corollary 5.2.9 implies that if $n = 2$ and $\dim V_0 = \dim V_1 = p$ then $\dim \mathcal{N} = 2p^2 - p$, so $\dim(V \times \mathcal{N}) = 2p^2 + p$. Since $\dim K = 2p^2 < \dim(V \times \mathcal{N})$, there is no hope that $K \setminus (V \times \mathcal{N})$ is finite, so Ψ is clearly not surjective. This is the case in general if $n > 1$. We will, however, see that $K \setminus (\tilde{V} \times \mathcal{N})$ is always contained in the image of Ψ , hence is finite.

Our goal now is to determine when two marked colored partitions are in the same fiber of Ψ . As might be guessed from the terminology introduced earlier in this section, the answer is related to striped n -bipartitions. We will see that if $\mathcal{O} \in K \setminus (\tilde{V} \times \mathcal{N})$ then the fiber of Ψ over \mathcal{O} consists of a single class in $\tilde{Q}_{\xi(V)}$.

Definition 4.2.2. If $(v, x) \in V \times \mathcal{N}$ then a *normal basis* for (v, x) is a colored Jordan basis $\mathcal{B} = \{v_{i,j}\}$ for x such that there is a generalized striped n -bipartition (λ, ϵ, μ) satisfying

1. (λ, ϵ) is the type of \mathcal{B} ,

2.
$$v = \sum_{i=1}^{l(\lambda)} v_{i,\mu_i}.$$

In general, not every element of $V \times \mathcal{N}$ admits a normal basis. In fact, it is clear that if (v, x) admits a normal basis with corresponding generalized striped n -bipartition (λ, ϵ, μ) then $\Psi(\lambda, \epsilon, \mu) = \mathcal{O}_{v,x}$. So, if (v, x) admits a normal basis then $\mathcal{O}_{v,x}$ is in the image of Ψ . We will see that the converse is true, as well: if $\mathcal{O}_{v,x}$ is in the image of Ψ

then (v, x) admits a normal basis. As a first step, we observe the following lemma, which suggests that the existence of a normal basis is an important orbit invariant.

Lemma 4.2.3. *If (v, x) admits a normal basis then so does each element of $\mathcal{O}_{v,x}$. Moreover, (v, x) and (w, y) each admit a normal basis corresponding to the same generalized striped n -bipartition if and only if $\mathcal{O}_{v,x} = \mathcal{O}_{w,y}$.*

Proof. Let \mathcal{B} be a normal basis for (v, x) with corresponding generalized striped n -bipartition (λ, ϵ, μ) . If $k \cdot (v, x) = (w, y)$ then $k \cdot \mathcal{B}$ is a normal basis for (w, y) with corresponding generalized striped n -bipartition (λ, ϵ, μ) . Conversely, if we fix normal bases for (v, x) and (w, y) corresponding to the same generalized striped n -bipartition then the obvious change of basis transformation lies in K . \square

Definition 4.2.4. Let (λ, ϵ, μ) be a marked colored partition and let $\mathcal{B} = \{v_{i,j}\}$ be a colored basis of type (λ, ϵ) . Then we write

$$\mathcal{B}^\mu = \{v_{i,j} \in \mathcal{B} \mid 1 \leq j \leq \mu_i\}.$$

Lemma 4.2.5. *Let $x \in \mathcal{N}$ have a colored Jordan basis $\mathcal{B} = \{v_{i,j}\}$ of type (λ, ϵ) and let μ be a marking of λ . Then*

1. $\langle \mathcal{B}^\mu \rangle$ is colored and x -stable;
2. \mathcal{B}^μ is a colored Jordan basis for $x|_{\langle \mathcal{B}^\mu \rangle}$ of type $(\mu, \epsilon + [\lambda - \mu])$;
3. $\mathcal{B} \setminus \mathcal{B}^\mu$ is a colored Jordan basis for $x|_{V/\langle \mathcal{B}^\mu \rangle}$ of type $(\lambda - \mu, \epsilon)$;
4. If $\mu_i \in \{0, \lambda_i\}$ for each i then $\langle \mathcal{B}^{\lambda - \mu} \rangle$ is x -stable and $x|_{\langle \mathcal{B}^{\lambda - \mu} \rangle}$ and $x|_{V/\langle \mathcal{B}^\mu \rangle}$ have the same colored Jordan type.

Notation 4.2.6. We may speak of *deleting* a row or collection of rows from a partition, colored partition, or marked colored partition. Let $\iota_k : \mathbb{N} \rightarrow \mathbb{N}$ be defined by

$$\iota_k(i) = \begin{cases} i & i < k \\ i + 1 & i \geq k. \end{cases}$$

To delete row k from (λ, ϵ, μ) is to construct $\Delta_k(\lambda, \epsilon, \mu) = (\lambda \circ \iota_k, \epsilon \circ \iota_k, \mu \circ \iota_k)$. The deletion of row k from a partition or colored partition is performed analogously. If $S \subset \mathbb{N}$ is finite, we may delete from (λ, ϵ, μ) all the rows indexed by elements of S in the obvious way: Let $a_1 < a_2 < \dots < a_r$ be the elements of S . We simply construct $\Delta_S(\lambda, \epsilon, \mu) = (\lambda \circ \iota, \epsilon \circ \iota, \mu \circ \iota)$,

where $\iota = \iota_{a_1} \circ \cdots \circ \iota_{a_r}$. The order of the composition is significant here, because ι_k and $\iota_{k'}$ do not commute if $k \neq k'$. If $k' < k$ then $\iota_k \circ \iota_{k'} = \iota_{k'+1} \circ \iota_k$.

Lemma 4.2.7. *Let $\mathcal{B} = \{v_{i,j}\}$ be a normal basis for $(v, x) \in V \times \mathcal{N}$ with corresponding generalized striped n -bipartition (λ, ϵ, μ) and let $S \subset \{1, \dots, l(\lambda)\}$. If we set*

$$\mu_i = \begin{cases} \lambda_i & i \in S \\ 0 & i \notin S. \end{cases}$$

and $A = \langle \mathcal{B}^\mu \rangle$ then $\mathcal{B}^{\lambda-\mu}$ is a normal basis for $(v + A, \bar{x}) \in (V/A) \times \mathcal{N}(V/A)$ with corresponding generalized striped n -bipartition $\Delta_S(\lambda, \epsilon, \mu)$.

Theorem 4.2.8.

1. *The image of Ψ (definition 4.2.1) is precisely the set of enhanced K -orbits whose elements admit a normal basis (definition 4.2.2). That is, each fiber of Ψ contains a generalized striped n -bipartition (definition 4.1.1).*
2. $\Psi : \tilde{\mathcal{Q}}_{\xi(V)} \rightarrow K \backslash (\tilde{V} \times \mathcal{N})$ *is a bijection. That is,*
 - (a) *If $\mathcal{O} \in K \backslash (V \times \mathcal{N})$ then $\mathcal{O} \in K \backslash (\tilde{V} \times \mathcal{N})$ if and only if there is a striped n -bipartition (λ, ϵ, μ) such that $\Psi(\lambda, \epsilon, \mu) = \mathcal{O}$;*
 - (b) *If $(v, x) \in \tilde{V} \times \mathcal{N}$ and $v \neq 0$ then any two striped n -bipartitions that correspond to $\mathcal{O}_{v,x}$ are identical, up to permuting rows.*
 - (c) *If $x \in \mathcal{N}$ and $v = 0$ then the striped n -bipartitions corresponding to $\mathcal{O}_{v,x}$ are precisely $\rho_m(\lambda, \epsilon, 0)$, where (λ, ϵ) is the colored Jordan type of x and $m \in \mathbb{Z}/n\mathbb{Z}$.*

Proof. We use the proof in [1] as a model. In fact, the only obstacle to following this proof exactly is that we must be careful to preserve the colored structure of V . The procedure described below gives a simple algorithm for producing the generalized striped n -bipartition associated to $(v, x) \in \tilde{V} \times \mathcal{N}$.

To prove (1) we observe, first of all, that if $\mathcal{O}_{v,x} = \Psi(\lambda, \epsilon, \mu)$ then we can trivially assume that $\mu_i > -n$ for each i . Let $\mathcal{B} = \{v_{i,j}\}$ be a colored Jordan basis for x of type (λ, ϵ) such that $v = \sum v_{i,\mu_i}$. We will iteratively modify \mathcal{B} until $\mu_j < \mu_i + n$ and $\nu_j < \nu_i + n$ for each $i < j$ such that $\epsilon_i + [\nu_i] = \epsilon_j + [\nu_j]$. Suppose there exists a pair $i < j$ that fails. Note that, since $\mu_i + \nu_i = \lambda_i$ and $\lambda_i \geq \lambda_j$, we cannot have both $\mu_i + n \leq \mu_j$ and $\nu_i + n \leq \nu_j$.

If $\mu_i + n \leq \mu_j$ then for each r define

$$w_{k,r} = \begin{cases} v_{i,\mu_i+n} + v_{i,\mu_i} & k = i \\ v_{j,r} - v_{i,r-\mu_j+\mu_i+n} & k = j \\ v_{k,r} & k \neq i, j. \end{cases}$$

Then $\{w_{i,j}\}$ is a colored Jordan basis for x of type (λ, ϵ) and

$$v = \sum_k v_{k,\mu_k} = \sum_{k \neq i} w_{k,\mu_k} + w_{i,\mu_i+n}.$$

Therefore, we have effectively redefined μ_i to be $\mu_i + n$, leaving μ otherwise unchanged. Pictorially, we have moved the mark in row i to the right by n positions.

If $\nu_i + n \leq \nu_j$, define

$$w_{k,r} = \begin{cases} v_{i,r} - v_{j,r-\mu_i+\mu_j+n} & k = i \\ v_{j,\mu_j+n} + v_{j,\mu_j} & k = j \\ v_{k,r} & k \neq i, j. \end{cases}$$

By similar reasoning, this effectively redefines μ_j to be $\mu_j + n$. Pictorially, we have moved the mark in row j to the right by n positions.

We repeat this step as long as it is possible. The condition $\epsilon_i + [\nu_i] = \epsilon_j + [\nu_j]$ ensures that this change of basis can be accomplished by an element of K . The condition $\lambda_i \geq \lambda_j$ plus $\mu_i + n \leq \mu_j$ (resp. $\nu_i + n \leq \nu_j$) ensures that each iteration results in a valid marking of λ , i.e., $\mu_i \leq \lambda_i$ for each i . Each iteration also increases the quantity $\sum_{i,\lambda_i > 0} \mu_i \leq |\lambda|$, so this process must eventually terminate, yielding the appropriate inequalities. Note that each iteration also preserves the quantity $\epsilon + [\lambda - \mu]$.

To prove (a) we fix $(v, x) \in \tilde{V} \times \mathcal{N}$ and let $\mathcal{B} = \{v_{i,j}\}$ be a colored Jordan basis for x of type (λ, ϵ) . If $v = 0$ then $\mathcal{O}_{v,x} = \Psi(\rho_m(\lambda, \epsilon, 0))$ for each m . Otherwise, set $m = \chi(v)$, $v = \sum_{i,j} a_{i,j} v_{i,j}$, and $v_i = \sum_j a_{i,j} v_{i,j}$. By applying (6) from lemma 3.3.2 to each Jordan block, noting that v_i is colored, we may assume that v_{i,λ_i} is colored and $v_i = x^{\nu_i} v_{i,\lambda_i}$ for some $0 \leq \nu_i \leq \lambda_i$. If $v_i \neq 0$ then $\chi(v_i) = m$. Otherwise, redefine $\nu_i = \min\{t \in \mathbb{Z} \mid t \geq \lambda_i, \epsilon_i + [t] = m\}$. Then $\Psi(\lambda, \epsilon, \mu) = \mathcal{O}_{v,x}$, where $\mu = \lambda - \nu$. Note that by construction we have $\epsilon + [\lambda - \mu] = m$, so the algorithm in (1) yields a striped n -bipartition.

We now wish to show that $\Psi|_{\tilde{\mathcal{Q}}_{\epsilon(V)}}$ is injective. Let $(v, x) \in \tilde{V} \times \mathcal{N}$ and let $\mathcal{B} = \{v_{i,j}\}$ be a normal basis for (v, x) with striped n -bipartition (λ, ϵ, μ) . Since $v = \sum_i v_{i,\mu_i}$ it is clear that if $v = 0$ then $\mu_i \leq 0$. But if a color m is fixed then for each $i \in \mathbb{N}$ there is a

unique μ_i satisfying $-n < \mu_i \leq 0$ and $\epsilon_i + [\lambda_i] - [\mu_i] = m$, so $(\lambda, \epsilon, \mu) = \rho_m(\lambda, \epsilon, 0)$. As m varies, these striped n -bipartitions all lie in the same equivalence class in $\tilde{\mathcal{Q}}_{\xi(V)}$ and (c) is proved.

We may, therefore, assume that $v \neq 0$. Since $v = \sum_i v_i \mu_i$, lemma 3.3.2 implies that $\dim \mathbb{F}[x](v) = \max\{\mu_i \mid 1 \leq i \leq l(\lambda)\}$. Therefore, there is an integer i with $\mu_i = \dim \mathbb{F}[x](v)$. Since (λ, ϵ, μ) is an n -bipartition we have

$$[\dim \mathbb{F}[x](v)] = [\mu_i] = \epsilon_i + [\lambda_i] - \chi(v).$$

We can, therefore, set $k = \min\{i \mid \epsilon_i + [\lambda_i] = [\dim \mathbb{F}[x](v)] + \chi(v)\}$, noting that this expression is independent of μ . By congruence there is an integer j such that $\mu_k = \mu_i + jn$. But $k \leq i$, so $\mu_k + n > \mu_i$, so $jn > -n$, i.e., $j > -1$, hence $j \geq 0$ and $\mu_k \geq \mu_i = \dim \mathbb{F}[x](v)$. But maximality of μ_i forces $\mu_k \leq \mu_i = \dim \mathbb{F}[x](v)$. Therefore, $\mu_k = \dim \mathbb{F}[x](v)$. In other words, the marking of the longest row of (λ, ϵ) satisfying $\epsilon_k + [\lambda_k] = [\dim \mathbb{F}[x](v)] + \chi(v)$ is forced upon us.

Set $S = \{k\}$ and build A as in lemma 4.2.7. Then $\Delta_k(\lambda, \epsilon, \mu)$ is a striped n -bipartition that corresponds to $x|_{V/A}$. Inductively, the striped n -bipartition corresponding to $x|_{V/A}$ is unique, so μ_i is also completely determined if $i \neq k$. There is one case that must be considered carefully. If $v \in A$ then $v + A \in V/A$ is the zero vector. We saw above that there are n markings δ of $\Delta_k(\lambda, \epsilon)$ that are valid in this case. However, there is only one satisfying $\epsilon + [\lambda - \delta] = m$, proving (b). \square

Corollary 4.2.9. *If $m \in \mathbb{Z}/n\mathbb{Z}$ is fixed then $K \setminus (V_m \times \mathcal{N})$ is in bijection with the set of striped n -bipartitions (λ, ϵ, μ) of signature $\xi(V)$ such that $\epsilon + [\lambda - \mu] = m$, via the map Ψ .*

Corollary 4.2.10. *Let (λ, ϵ) be a colored partition and let $m \in \mathbb{Z}/n\mathbb{Z}$. Then*

1. $V_m \times \mathcal{O}_{\lambda, \epsilon} = \bigsqcup_{\substack{\mu \\ \epsilon + [\lambda - \mu] = m \\ (\lambda, \epsilon, \mu) \in \mathcal{Q}_{\xi(V)}}} \mathcal{O}_{\lambda, \epsilon, \mu}$
2. $\mathcal{O}_{\rho_m(\lambda, \epsilon, 0)} = \{0\} \times \mathcal{O}_{\lambda, \epsilon} \cong \mathcal{O}_{\lambda, \epsilon}$.

4.3 Connections to classical orbits

Proposition 4.3.1. *Let $m \in \mathbb{Z}/n\mathbb{Z}$ and let (λ, ϵ, μ) be a marked colored partition satisfying $\epsilon + [\lambda - \mu] = m$. Let $(\lambda, \epsilon, \bar{\mu})$ be a striped n -bipartition such that $\Psi(\lambda, \epsilon, \mu) = \Psi(\lambda, \epsilon, \bar{\mu})$. Then $\bar{\rho}(\lambda, \epsilon, \mu) = \bar{\rho}(\lambda, \epsilon, \bar{\mu})$, so $(\lambda, \epsilon, \bar{\mu}) = \rho_m(\bar{\rho}(\lambda, \epsilon, \mu))$.*

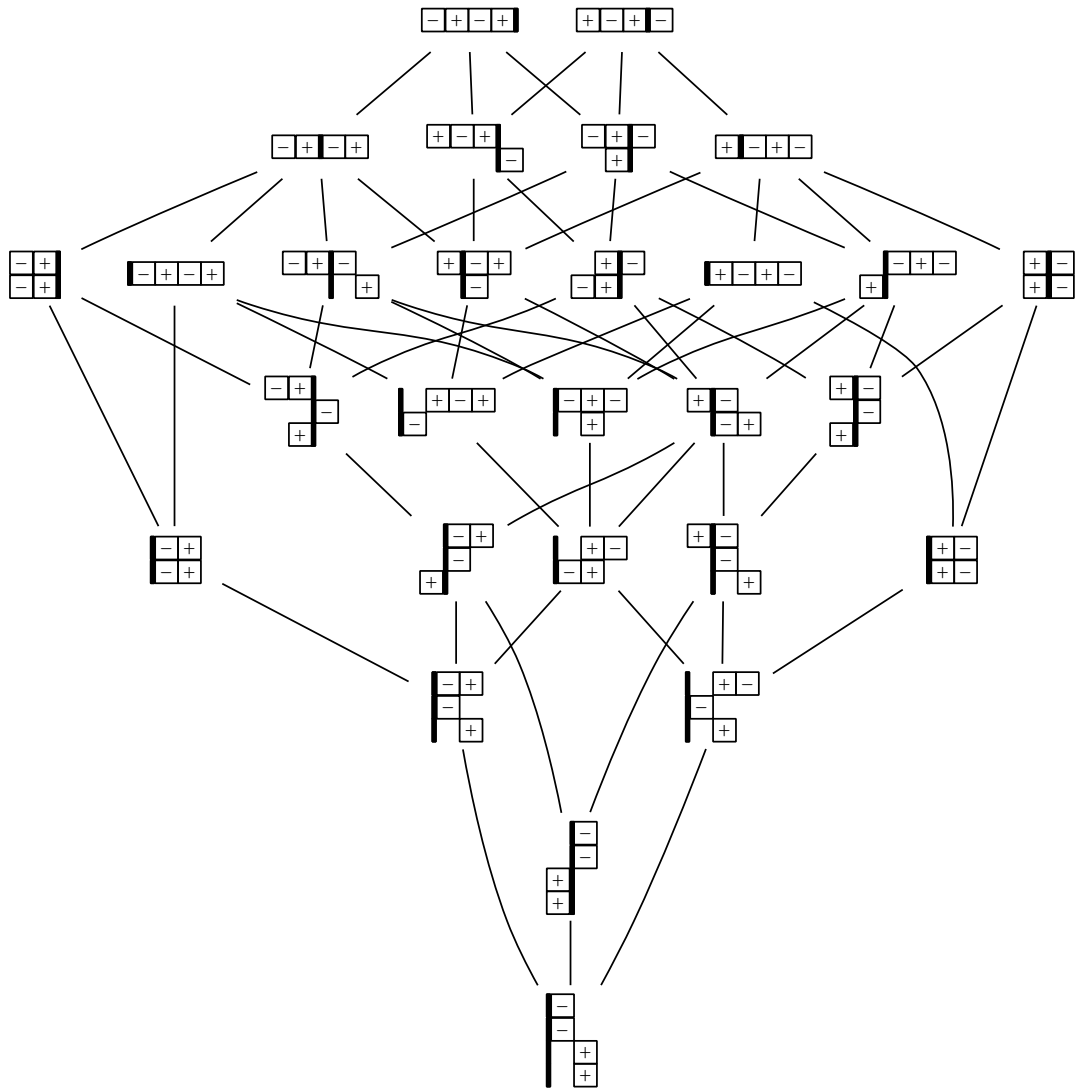

Figure 4.2. Orbits parametrized by signed 2-bipartitions. Here we see all the orbits in $K \setminus (V_0 \times \mathcal{N})$, for $n = 2$ and signature $(2, 2)$, parametrized by signed 2-bipartitions and ranked by dimension. The bottommost orbit is zero. The next orbit up has dimension 2. Dimension increases by one at each rank until the topmost orbits each have dimension 8. An edge indicates that the lower orbit lies in the Zariski closure of the upper orbit.

Proof. Let δ be a marking of λ obtained from μ by one step of the iterative portion of the proof of theorem 4.2.8. Let $(\lambda, \epsilon, \tilde{\mu}) = \bar{\rho}(\lambda, \epsilon, \mu)$ and $(\lambda, \epsilon, \tilde{\delta}) = \bar{\rho}(\lambda, \epsilon, \delta)$. We will show that $\tilde{\mu} = \tilde{\delta}$. Therefore, for a fixed orbit the marking $\tilde{\mu}$ is the same, regardless of the representative marking used to construct $\tilde{\mu}$.

If (λ, ϵ, μ) is not a striped n -bipartition then there exist $s < r$ with either $\mu_s + n \leq \mu_r$ or $\nu_s + n \leq \nu_r$. We need to show that if δ is constructed in either of these cases then $\tilde{\delta} = \tilde{\mu}$. The second case is entirely analogous to the first, so we will only prove the first case. Assume that $s < r$ and $\mu_s + n \leq r$. Then

$$\delta_k = \begin{cases} \mu_s + n & k = s \\ \mu_k & k \neq s. \end{cases}$$

The formulas for $\tilde{\mu}$ and $\tilde{\delta}$ make it clear that $\tilde{\mu} \leq \tilde{\delta}$. On the other hand, the same formulas show that if $\tilde{\delta}_k > \tilde{\mu}_k$ then either $k \leq s$ and $\tilde{\delta}_k = \delta_s$ or $k > s$ and $\tilde{\delta}_k = \delta_s + \lambda_k - \lambda_s$. Here we divide our effort into three cases:

1. If $k \leq s$ then $k < r$ and $\tilde{\delta}_k = \delta_s = \mu_s + n \leq \mu_r \leq \tilde{\mu}_k$.
2. If $s < k < r$ then $\tilde{\delta}_k = \delta_s + \lambda_k - \lambda_s \leq \delta_s = \mu_s + n \leq \mu_r \leq \tilde{\mu}_k$.
3. If $k > r$ then $\tilde{\delta}_k = \delta_s + \lambda_k - \lambda_s = \mu_s + n + \lambda_k - \lambda_s \leq \mu_r + \lambda_k - \lambda_s \leq \mu_r + \lambda_k - \lambda_r \leq \tilde{\mu}_k$.

In each case we have a contradiction, so $\tilde{\delta}_k \leq \tilde{\mu}_k$ for each k and we have $\tilde{\delta} = \tilde{\mu}$. Inductively, we just need to apply an adequate number of iterations until we arrive at the striped n -bipartition. The last claim follows because $\rho_m \circ \bar{\rho}$ fixes striped n -bipartitions. \square

Corollary 4.3.2. *If $\epsilon + [\lambda - \mu] = \epsilon + [\lambda - \delta] = m$ then $\mathcal{O}_{\lambda, \epsilon, \mu} = \mathcal{O}_{\lambda, \epsilon, \delta}$ if and only if $\bar{\rho}(\lambda, \epsilon, \mu) = \bar{\rho}(\lambda, \epsilon, \delta)$. So, if m is fixed then $K \setminus (V_m \times \mathcal{N})$ is parametrized by minimal bipartitions.*

Lemma 4.3.3. *Let k be a divisor of n and let $\zeta_k : \mathbb{Z}/n\mathbb{Z} \rightarrow \mathbb{Z}/k\mathbb{Z}$ be the natural projection.*

For $m \in \mathbb{Z}/k\mathbb{Z}$ define $W_m = \bigoplus_{\zeta_k(i)=m}^{n/k} V_i$. Then

1. $(V, W_{[0]}, \dots, W_{[k-1]})$ is a k -colored vector space.
2. If $x \in \mathcal{N}$ then $xW_m \subset W_{m+[1]}$ for each $m \in \mathbb{Z}/k\mathbb{Z}$.

That is, x is colored relative to the subspaces W_i . Moreover, K naturally embeds in $GL(W_0) \times \dots \times GL(W_{n-1})$. In other words, if we reduce the number of colors to k

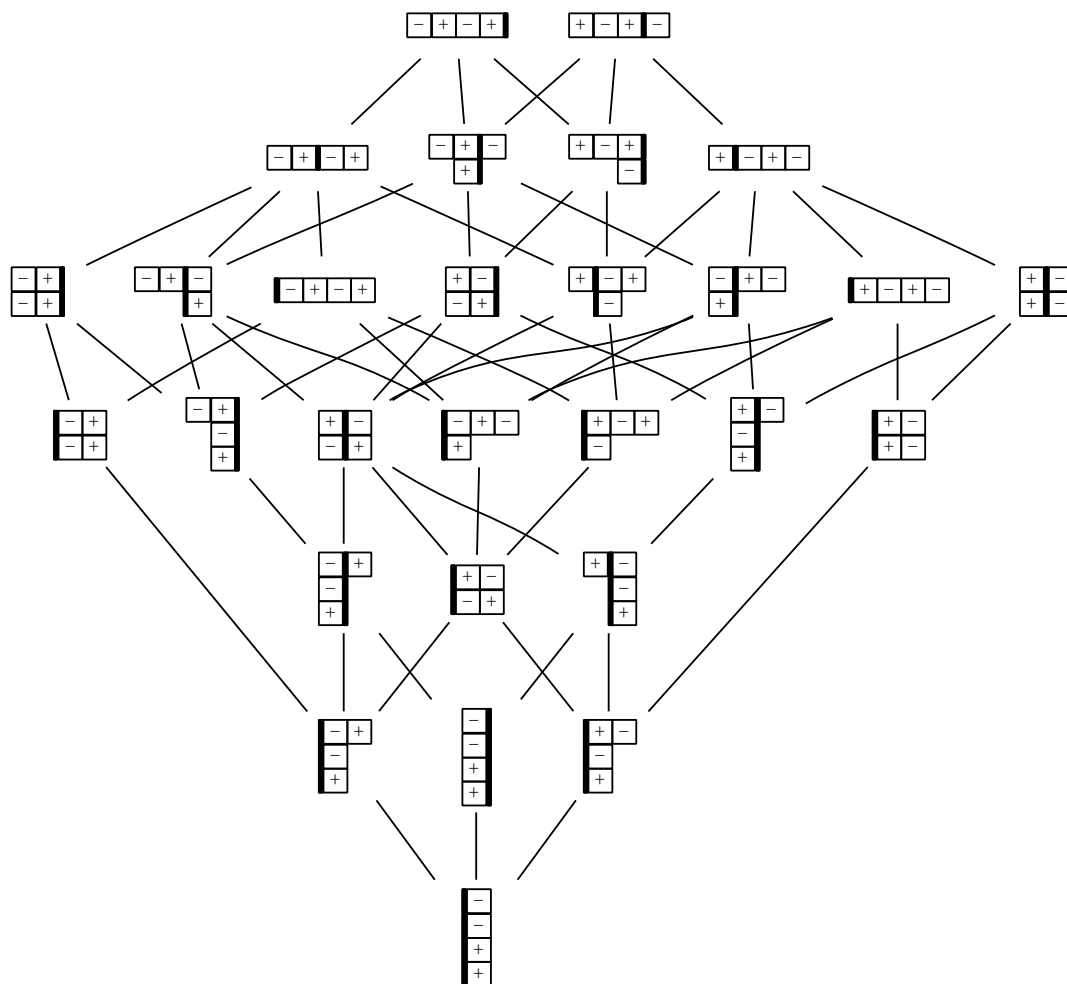

Figure 4.3. Orbits parametrized by minimal bipartitions. Compare with figure 4.2.

(combining all colors that are congruent modulo k) then we get a new colored nilpotent cone and we can view x inside this larger cone. Since the identity map $V \rightarrow V$ is K -equivariant, we have an induced map Φ_k of orbits. On the other hand, we have an obvious map of marked colored partitions that reduces the number of colors to k : $\phi_k(\lambda, \epsilon, \mu) = (\lambda, \zeta_k \circ \epsilon, \mu)$. Unsurprisingly, these two maps are compatible. The case $k = 1$ is especially illuminating.

Proposition 4.3.4. *If (λ, ϵ, μ) is any marked partition then $\Psi \circ \phi_k = \Phi_k \circ \Psi$. That is, $\Phi_k(\mathcal{O}_{\lambda, \epsilon, \mu}) = \mathcal{O}_{\phi_k(\lambda, \epsilon, \mu)}$.*

Corollary 4.3.5. *If (λ, ϵ, μ) is a striped n -bipartition and the minimal bipartition of (λ, μ) is $(\lambda, \tilde{\mu})$ then $\Psi(\phi_1(\lambda, \epsilon, \mu)) = \mathcal{O}_{\lambda, \tilde{\mu}} = \mathcal{O}_{\tilde{\mu}; \lambda - \tilde{\mu}}$, is the bipartition given in [1].*

On the other hand, we have a natural K -equivariant projection $\theta : \tilde{V} \times \mathcal{N} \rightarrow \mathcal{N}$. It should be clear that $\theta(\mathcal{O}_{\lambda, \epsilon, \mu}) = \mathcal{O}_{\lambda, \epsilon}$. In other words, our parametrization is well-behaved relative to each setting that we are trying to generalize. It projects in the most natural way possible to the colored nilpotent cone and to the setting explored in [1].

4.4 An alternative parametrization

Fix an orbit \mathcal{O} in the image of Ψ and let (λ, ϵ) be the corresponding colored partition. Then

$$S_{\mathcal{O}} = \{\mu \geq 0 \text{ a marking of } \lambda \mid \Psi(\lambda, \epsilon, \mu) = \mathcal{O}\}$$

is partially ordered by the rule $\delta \leq \mu$ if $\delta_i \leq \mu_i$ for each i . Since $S_{\mathcal{O}}$ is finite and nonempty, $S_{\mathcal{O}}$ has at least one minimal element. A primary objective of this subsection is to show that the minimal element is unique up to row equivalence. Throughout this subsection, if $\mu \in S_{\mathcal{O}}$ then let $\tilde{\mu} \in S_{\mathcal{O}}$ be defined by the usual formula

$$\tilde{\mu}_i = \max(\{\mu_j \mid j \geq i\} \cup \{\lambda_i - (\lambda_j - \mu_j) \mid j \leq i\}).$$

Lemma 4.4.1. *If $\mu \in S_{\mathcal{O}}$ is minimal and $i < j$ satisfy $\mu_i > 0$, $\mu_j > 0$, and $\epsilon_j + [\lambda_j - \mu_j] = \epsilon_i + [\lambda_i - \mu_i]$ then $\mu_i > \mu_j$ and $\lambda_i - \mu_i > \lambda_j - \mu_j$. In particular, $\lambda_i \geq \lambda_j + 2$.*

Proof. Define

$$\delta_k = \begin{cases} \max\{\mu_i - n, 0\} & k = i \\ \mu_k & k \neq i, \end{cases}$$

$$\gamma_k = \begin{cases} \max\{\mu_j - n, 0\} & k = j \\ \mu_k & k \neq j. \end{cases}$$

If $\mu_i \leq \mu_j$ then $\delta < \mu$ and the algorithm in theorem 4.2.8 shows that $\delta \in S$. On the other hand, if $\lambda_i - \mu_i \leq \lambda_j - \mu_j$ then $\gamma < \mu$ and $\gamma \in S$. In either case, minimality of μ is violated. Now, if $\mu_i > \mu_j$ and $\lambda_i - \mu_i > \lambda_j - \mu_j$ then $\mu_i \geq \mu_j + 1$ and $\lambda_i - \mu_i \geq \lambda_j - \mu_j + 1$. We just add these two inequalities to prove the last claim. \square

Lemma 4.4.2. *If $\mu \in S_{\mathcal{O}}$ is minimal and $\mu_i > 0$ then $\tilde{\mu}_i = \mu_i$.*

Proof. By lemma 4.4.1, if $j > i$ then $\mu_j < \mu_i$, so

$$\begin{aligned}\tilde{\mu}_i &= \max\{\lambda_i - (\lambda_j - \mu_j) \mid j \leq i\} \\ &= \lambda_i - \min\{\lambda_j - \mu_j \mid j \leq i\}.\end{aligned}$$

Again, the lemma shows that if $j < i$ then either $\mu_j = 0$, so $\lambda_j - \mu_j = \lambda_j \geq \lambda_i \geq \lambda_i - \mu_i$, or $\lambda_j - \mu_j > \lambda_i - \mu_i$. Therefore, $\min\{\lambda_j - \mu_j \mid j \leq i\} = \lambda_i - \mu_i$ and the claim is proved. \square

Theorem 4.4.3. *Let \mathcal{O} be in the image of Ψ and let (λ, ϵ) be a corresponding colored partition. Then*

1. *There is a minimal marking μ of λ satisfying*

(a) $\Psi(\lambda, \epsilon, \mu) = \mathcal{O}$;

(b) $\mu \geq 0$;

(c) *If $\delta \leq \mu$ is any marking of λ satisfying (a) and (b) then $\delta = \mu$.*

2. *If μ satisfies (a) and (b) then there exists $\delta \leq \mu$ that is minimal in the sense of (c).*

3. *If μ and δ are each minimal then (λ, ϵ, μ) and $(\lambda, \epsilon, \delta)$ are row-equivalent.*

4. *If μ satisfies (a) and (b) then μ is minimal if and only if $\mu_i > \mu_j$ and $\lambda_i - \mu_i > \lambda_j - \mu_j$ for every pair $i < j$ satisfying $\mu_i > 0$, $\mu_j > 0$, and $\epsilon_j + [\lambda_j - \mu_j] = \epsilon_i + [\lambda_i - \mu_i]$.*

Proof. Claim (1) is just a restatement of the fact that $S_{\mathcal{O}}$ contains at least one minimal element. Claim (2) follows from the proof of lemma 4.4.1 once we have proved (4). We will show that any μ and δ satisfying the inequalities given in (4) must be equivalent. The rest follows immediately from lemma 4.4.1 because any minimal marking must satisfy these inequalities.

We begin with the case $\mathcal{O} \in K \setminus (\tilde{V} \times \mathcal{N})$. First, observe that $\Psi(\lambda, \epsilon, \mu) = \Psi(\lambda, \epsilon, \delta)$ forces $\tilde{\mu} = \tilde{\delta}$. So, if $\mu_i \neq \delta_i$ then by lemma 4.4.2 exactly one of these must be zero. Let i

be the smallest index with $\mu_i \neq \delta_i$. We may assume with no loss of generality that $\mu_i > 0$ and $\delta_i = 0$.

Since $\tilde{\delta}_i = \tilde{\mu}_i = \mu_i > 0 = \delta_i$, there is either $k < i$ with $\lambda_i - (\lambda_k - \delta_k) = \mu_i$ or $j > i$ with $\delta_j = \mu_i$. In the first case, $\lambda_i - \mu_i = \lambda_k - \delta_k$. By minimality of i we have $\mu_k = \delta_k$, so $\lambda_i - \mu_i = \lambda_k - \mu_k$. By lemma 4.4.1 we must have $\mu_k = 0$, so $\lambda_k = \lambda_i - \mu_i < \lambda_i$, a contradiction.

We conclude that there exists $j > i$ with $\delta_j = \mu_i > \mu_j$, so $\mu_j = 0$. Now, if $k > j$ is arbitrary then $\mu_k < \mu_i = \tilde{\mu}_j$, so $\tilde{\mu}_j = \max\{\lambda_j - (\lambda_k - \mu_k) \mid k < j\}$. Therefore, there exists $k < j$ with $\mu_i = \lambda_j - (\lambda_k - \mu_k) \leq \mu_k$, hence $\mu_k > 0$ and $k \leq i$. Now, $\mu_i = \lambda_j - (\lambda_k - \mu_k) \leq \lambda_i - (\lambda_k - \mu_k)$, hence $\lambda_i - \mu_i \geq \lambda_k - \mu_k$. Since $\mu_i > 0$ and $\mu_k > 0$, we must have $k \geq i$.

Since $k = i$ we have $\mu_i = \lambda_j - (\lambda_i - \mu_i)$, hence $\lambda_j = \lambda_i$. Now, $\epsilon_j + [\lambda_j - \mu_j] = \epsilon_i + [\lambda_i - \mu_i]$, so $\epsilon_j = \epsilon_i + [\mu_j - \mu_i] = \epsilon_i + [\delta_j - \mu_i] = \epsilon_i$. Therefore, rows j and i of (λ, ϵ) are identical. By swapping rows i and j of δ we obtain a new marking of (λ, ϵ) that is minimal and agrees with μ for all rows $k \leq i$. The result follows by induction.

For the general case, let $x \in \mathcal{O}_{\lambda, \epsilon}$ and let $\mathcal{B} = \{v_{i,j}\}$ be a colored Jordan basis for x of type (λ, ϵ) . If we write $v = \sum v_{i, \mu_i}$ and $w = \sum v_{i, \delta_i}$ then there is an element $k \in K$ such that $k \cdot x = x$ and $kv = w$. For each $m \in \mathbb{Z}/n\mathbb{Z}$, write

$$\mu_i^m = \begin{cases} \mu_i & \epsilon_i + [\lambda_i - \mu_i] = m \\ 0 & \text{otherwise;} \end{cases}$$

$$\delta_i^m = \begin{cases} \delta_i & \epsilon_i + [\lambda_i - \delta_i] = m \\ 0 & \text{otherwise.} \end{cases}$$

Set $v_m = \sum v_{i, \mu_i^m}$ and $w_m = \sum v_{i, \delta_i^m}$. Then $v = \sum v_m$ and $w = \sum w_m$. It is evident that $kv = w$, so (v, x) and (w, x) lie in the same orbit in $K \backslash (\tilde{V} \times \mathcal{N})$. But μ^m and δ^m are minimal by (4), hence $(\lambda, \epsilon, \mu^m)$ and $(\lambda, \epsilon, \delta^m)$ must be equivalent by (3). This shows that we need only reorder the rows color by color to get the result we desire. \square

Let \mathcal{P}_n^m denote the set of equivalence classes of marked n -colored partitions. We define a binary operation $\cup : \mathcal{P}_n^m \times \mathcal{P}_n^m \rightarrow \mathcal{P}_n^m$ as follows. Let (λ, ϵ, μ) and (α, β, γ) be representatives of elements of \mathcal{P}_n^m . We can define $(\lambda, \epsilon, \mu) \cup (\alpha, \beta, \gamma)$ to be the equivalence class of $(\Lambda(\lambda, \alpha), \Lambda(\epsilon, \beta), \Lambda(\mu, \gamma))$, where

$$\Lambda(f, g)(i) = \begin{cases} f(i/2) & i \text{ even,} \\ g((i+1)/2) & i \text{ odd.} \end{cases}$$

In other words, we interlace the rows of the two objects and then permute them to form a colored partition.

The operation \cup is well-defined on equivalence classes and defines an Abelian semigroup structure on \mathcal{P}_n^m . What is more, it is evident that $\xi : \mathcal{P}_n^m \rightarrow \{f : \mathbb{Z}/n\mathbb{Z} \rightarrow \mathbb{Z}^{\geq 0}\}$ is a homomorphism of semigroups:

$$\xi((\lambda, \epsilon, \mu) \cup (\alpha, \beta, \gamma)) = \xi(\lambda, \epsilon, \mu) + \xi(\alpha, \beta, \gamma).$$

The set \mathcal{P}_n of n -colored partitions is naturally a subsemigroup of \mathcal{P}_n^m via the embedding $(\lambda, \epsilon) \mapsto (\lambda, \epsilon, 0)$. Also, if k is a divisor of n then $\phi_k : \mathcal{P}_n^m \rightarrow \mathcal{P}_k^m$ is a surjective semigroup homomorphism.

If μ is a minimal marking of λ as given in the theorem then there is a well-defined way of decomposing (λ, ϵ, μ) by selecting exactly those rows with nonzero marking. Let $A = \{i \in \mathbb{N} \mid \mu_i > 0\}$ and $B = \{i \in \mathbb{N} \mid \lambda_i > 0, \mu_i = 0\}$. Then

$$(\lambda, \epsilon, \mu) = \Delta_B(\lambda, \epsilon, \mu) \cup \Delta_A(\lambda, \epsilon, \mu).$$

We call $\Delta_B(\lambda, \epsilon, \mu)$ the *characteristic* generalized striped n -bipartition of (λ, ϵ, μ) . If we set $(\alpha, \beta, \gamma) = \Delta_B(\lambda, \epsilon, \mu)$ then

1. $\gamma_i > 0$ for each $1 \leq i \leq l(\alpha)$;
2. $\gamma_i > \gamma_j$ and $\alpha_i - \gamma_i > \alpha_j - \gamma_j$ for each (i, j) satisfying $1 \leq i < j \leq l(\alpha)$ and $\beta_i + [\alpha_i - \gamma_i] = \beta_j + [\alpha_j - \gamma_j]$.

If $\beta_i + [\alpha_i - \gamma_i] = \beta_j + [\alpha_j - \gamma_j]$ for each $1 \leq i < j \leq l(\alpha)$ then we simply call $\Delta_B(\lambda, \epsilon, \mu)$ a *characteristic bipartition*.

On the other hand, if we set $(\alpha, \beta, \gamma) = \Delta_A(\lambda, \epsilon, \mu)$ then $\gamma_i = 0$ for each i . So, we have the following result:

Corollary 4.4.4. *The product \cup defines a bijection onto the image of Ψ from the set of pairs $((\lambda, \epsilon, \mu), (\alpha, \beta)) \in \mathcal{P}_n^m \times \mathcal{P}_n$ that satisfy*

1. $\xi(\lambda, \epsilon) + \xi(\alpha, \beta) = \xi(V)$;
2. (λ, ϵ, μ) is a characteristic generalized striped n -bipartition.

Corollary 4.4.5. *$K \setminus (\tilde{V} \times \mathcal{N})$ is in bijection with the set of pairs*

$$((\lambda, \epsilon, \mu), (\alpha, \beta)) \in \mathcal{P}_n^m \times \mathcal{P}_n$$

with $\xi(\lambda, \epsilon) + \xi(\alpha, \beta) = \xi(V)$ and (λ, ϵ, μ) a characteristic colored bipartition.

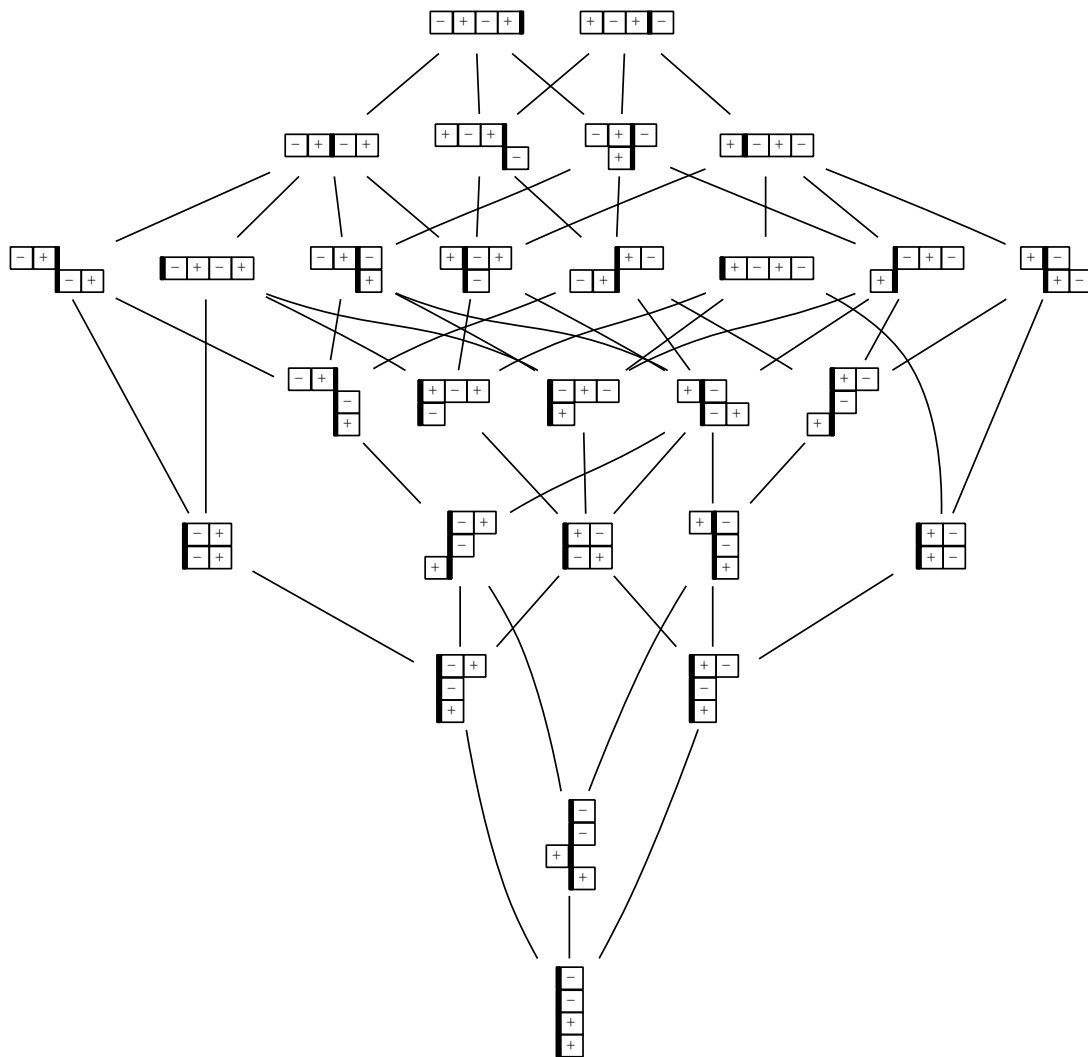

Figure 4.4. Orbits parametrized by characteristic bipartitions. Compare with figure 4.2.

CHAPTER 5

THE DIMENSION OF AN ORBIT

In this section we construct elementary formulas for the dimension of an orbit in $K \setminus \mathcal{N}$ or $K \setminus (\tilde{V} \times \mathcal{N})$. This enables us to easily compute the dimension of an orbit directly from a corresponding combinatorial parameter (colored partition or striped n -bipartition). We begin by presenting a few examples that are well known. We then construct a single formula that has each of these examples as a special case. As a consequence, we will obtain a simple formula for the enhanced signed case $n = 2$.

5.1 Known examples

By way of comparison, we present a few relevant examples from classical theory. We begin with a convenient formula. If λ is a partition and λ^t its transpose then we define

$$\eta(\lambda) = \sum_{i=1}^{l(\lambda)} (i-1)\lambda_i = \sum_{i=1}^{l(\lambda)} \binom{\lambda_i^t}{2}.$$

It is well known that $G = GL(V)$ acts on the set of nilpotent endomorphisms of V by conjugation. In our formulation, this is the case $n = 1$. The orbits are parametrized by partitions λ of size $k = \dim V$ and the dimension of the orbit corresponding to λ is given by

$$\dim \mathcal{O}_\lambda = 2 \binom{k}{2} - 2\eta(\lambda) = k^2 - \sum_{i=1}^{l(\lambda)} (\lambda_i^t)^2.$$

We discussed earlier that if $n = 2$ then $K \setminus \mathcal{N}$ is parametrized by signed partitions of signature $(\dim V_0, \dim V_1)$, hence of size $k = \dim V_0 + \dim V_1 = \dim V$. From classical theory we know that the dimension of the orbit corresponding to (λ, ϵ) is given by

$$\dim \mathcal{O}_{\lambda, \epsilon} = \binom{k}{2} - \eta(\lambda) = \frac{1}{2} \dim \mathcal{O}_\lambda = \frac{1}{2} \dim \phi_1(\mathcal{O}_{\lambda, \epsilon}).$$

Lastly, we mention the formula given in [1] ($n = 1$, once again). If $G = GL(V)$ acts on $V \times \mathcal{N}$ by conjugation (where here \mathcal{N} includes all nilpotent elements of $\text{End}(V)$) then

orbits are parametrized by bipartitions $(\mu; \nu)$, where $\lambda = \mu + \nu$ is any partition of size $k = \dim V$. The dimension of an orbit $\mathcal{O}_{\mu; \nu} \in G \backslash (V \times \mathcal{N})$ is

$$\dim \mathcal{O}_{\mu; \nu} = \dim \mathcal{O}_\lambda + |\mu| = \dim \mathcal{O}_\lambda = 2 \binom{k}{2} - 2\eta(\lambda) + |\mu|.$$

In the signed case one might guess, by analogy with the examples given above, that if (λ, ϵ, μ) is a striped 2-bipartition (or perhaps a related signed bipartition) then $\dim \mathcal{O}_{\lambda, \epsilon, \mu} = \frac{1}{2} \dim \mathcal{O}_\lambda + \frac{1}{2} |\mu| = \frac{1}{2} \dim \mathcal{O}_{\mu, \lambda - \mu}$. It is obvious from the outset, however, that this would be overly optimistic as there is no guarantee that this is even an integer. We will see, however, that the correct formula is as close to our guess as could reasonably be hoped.

5.2 The dimension formula

We once again find the Achar-Henderson strategy to be an excellent model for proving the general case. The following definitions and lemmas are entirely analogous to theirs. We just need to make a few minor changes to adapt them to our needs.

Definition 5.2.1. For fixed $(v, x) \in V \times \mathcal{N}$ we define the following auxiliary sets:

$$E^x = \{y \in \text{End}(V) \mid yx = xy\},$$

$$E^{v, x} = \{y \in E^x \mid y \cdot v = 0\},$$

$$F^x = \{y \in E^x \mid y(V_i) \subset V_i\},$$

$$F^{v, x} = \{y \in F^x \mid y \cdot v = 0\} = E^{v, x} \cap F^x,$$

$$K^x = F^x \cap K = E^x \cap K,$$

$$K^{v, x} = \{y \in K^x \mid y \cdot v = v\}.$$

Note that E^x , $E^{v, x}$, F^x , and $F^{v, x}$ are all linear spaces and that K^x and $K^{v, x}$ are subgroups of K .

Proposition 5.2.2. *If $(v, x) \in V \times \mathcal{N}$ then K^x and $K^{v, x}$ are connected algebraic groups and*

$$\dim \mathcal{O}_x = \dim K - \dim F^x,$$

$$\dim \mathcal{O}_{v, x} = \dim K - \dim F^x + \dim F^{v, x}.$$

Proof. K acts transitively on \mathcal{O}_x , so $\mathcal{O}_x \cong K/K^x$, hence $\dim \mathcal{O}_x = \dim K - \dim K^x$. Now, K^x is the principal open subvariety of (clearly connected) F^x determined by \det , so K^x is connected and $\dim K^x = \dim F^x$. Therefore, $\dim \mathcal{O}_x = \dim K - \dim F^x$.

Similarly, $\mathcal{O}_{v,x} \cong K/K^{v,x}$, hence $\dim \mathcal{O}_{v,x} = \dim K - \dim K^{v,x}$. $K^{v,x}$ is the principal open subvariety of $\{y \in F^x \mid y \cdot v = v\}$ (which is isomorphic to $F^{v,x}$ via the map $y \mapsto y - 1$) determined by \det . Therefore, $K^{v,x}$ is connected and $\dim K^{v,x} = \dim F^{v,x}$, so $\dim \mathcal{O}_{v,x} = \dim K - \dim F^{v,x}$. Lastly, the multiplication map $F^x \rightarrow F^{xv}$ defined by $y \mapsto y \cdot v$ is linear and surjective, with kernel equal to $F^{v,x}$. By the rank-nullity theorem, $\dim F^{xv} + \dim F^{v,x} = \dim F^x$, so $\dim \mathcal{O}_{v,x} = \dim K - \dim F^x + \dim F^{xv}$. \square

Proposition 5.2.3. *Fix $x \in \mathcal{N}$ and let $\mathcal{B} = \{v_{i,j}\}$ be a colored Jordan basis for x of type (λ, ϵ) . For $k, a, b \in \mathbb{N}$ satisfying $1 \leq a \leq l(\lambda)$ and $1 \leq b \leq \lambda_a$ let $y_{k,a,b}$ denote the linear endomorphism of V defined by $y_{k,a,b}(v_{k,j}) = v_{a,b+j-\lambda_k}$ and $y_{k,a,b}(v_{i,j}) = 0$ if $i \neq k$. Then*

1. E^x has basis $\mathcal{B}_E = \{y_{k,a,b} \mid 1 \leq k, a \leq l(\lambda), 1 \leq b \leq \min\{\lambda_a, \lambda_k\}\}$, so

$$\begin{aligned} \dim E^x &= \sum_{k=1}^{l(\lambda)} |s_{\lambda_k}(x)| \\ &= \dim V + 2\eta(\lambda). \end{aligned}$$

2. F^x has basis $\mathcal{B}_F = \{y_{k,a,b} \in \mathcal{B}_E \mid \epsilon_a + [\lambda_a - b] = \epsilon_k\}$, so

$$\dim F^x = \sum_{k=1}^{l(\lambda)} s_{\lambda_k}(x)(\epsilon_k).$$

Proof.

1. If $y \in E^x$ then $yv_{i,j} = yv_{i,\lambda_i - (\lambda_i - j)} = yx^{\lambda_i - j}v_{i,\lambda_i} = x^{\lambda_i - j}yv_{i,\lambda_i}$, so y is determined by the values of yv_{k,λ_k} . Write

$$yv_{k,\lambda_k} = \sum_{i,j} a_{i,j}v_{i,j} = \sum_{i,j} a_{i,j}y_{k,i,j}(v_{k,\lambda_k}),$$

so the span of the set of $y_{k,a,b}$ certainly contains E^x . That this set is linear independent follows from basic linear algebra. Therefore,

$$0 = y \cdot 0 = yx^{\lambda_k}v_{k,\lambda_k} = x^{\lambda_k}yv_{k,\lambda_k} = \sum_{i,j} a_{i,j}v_{i,j-\lambda_k}.$$

By linear independence, if $a_{i,j} \neq 0$ then $j - \lambda_k \leq 0$, hence $j \leq \lambda_k$. We conclude that E^x is contained in the span of \mathcal{B}_E . It is easy to verify, however, that each element of \mathcal{B}_E lies in E^x .

It is clear, then, that

$$\begin{aligned}
\dim E^x &= \sum_{k=1}^{l(\lambda)} \sum_{a=1}^{l(\lambda)} \#\{b \mid 1 \leq b \leq \min\{\lambda_a, \lambda_k\}\} \\
&= \sum_{k=1}^{l(\lambda)} \sum_{a=1}^k \#\{b \mid 1 \leq b \leq \lambda_k\} + \sum_{k=1}^{l(\lambda)} \sum_{a=k+1}^{l(\lambda)} \#\{b \mid 1 \leq b \leq \lambda_a\} \\
&= \sum_{k=1}^{l(\lambda)} \sum_{a=1}^k \lambda_k + \sum_{k=1}^{l(\lambda)} \sum_{a=k+1}^{l(\lambda)} \lambda_a \\
&= \sum_{k=1}^{l(\lambda)} k\lambda_k + \sum_{a=1}^{l(\lambda)} \sum_{k=1}^{a-1} \lambda_a \\
&= \sum_{k=1}^{l(\lambda)} \lambda_k + \sum_{k=1}^{l(\lambda)} (k-1)\lambda_k + \sum_{a=1}^{l(\lambda)} (a-1)\lambda_a \\
&= \dim V + 2\eta(\lambda).
\end{aligned}$$

The other formula for $\dim E^x$ follows from the fact that $E^x v_{k,\lambda_k} = \ker x^{\lambda_k}$.

2. If $y_{k,a,b} \in F^x$ then $\epsilon_k = \chi(v_{k,\lambda_k}) = \chi(y_{k,a,b} v_{k,\lambda_k}) = \chi(v_{a,b}) = \epsilon_a + [\lambda_a - b]$. We already know that such elements of \mathcal{B}_E are linearly independent and it is a quick exercise to verify that they are in F^x . The dimension formula should be clear once we observe that for fixed k the set $\{y_{k,a,b} v_{k,\lambda_k}\}$ is a basis for $\ker x^{\lambda_k} \cap V_{\epsilon_k}$. \square

Proposition 5.2.4. *Let $(v, x) \in V \times \mathcal{N}$. Let $\mathcal{B} = \{v_{i,j}\}$ be a colored Jordan basis for x of type (λ, ϵ) and write $v = \sum a_{i,j} v_{i,j}$. For convenience, set $a_{i,j} = 1$ if $j < 1$. For each $m \in \mathbb{Z}/n\mathbb{Z}$ we define a marking of λ : $\mu_i^m = \max\{j \in \mathbb{Z} \mid a_{i,j} \neq 0, \xi(v_{i,j}) = m\}$. We also define $\mu_i = \max\{j \in \mathbb{Z} \mid a_{i,j} \neq 0\} = \max\{\mu_i^m \mid m \in \mathbb{Z}/n\mathbb{Z}\}$. Let the corresponding minimal bipartitions be $(\lambda, \tilde{\mu}^m)$ and $(\lambda, \tilde{\mu})$. Then*

1. $\mathcal{B}^{\tilde{\mu}}$ is a colored Jordan basis for $E^x v$. In particular, $E^x v$ is colored and x -stable, with $\xi(E^x v) = \xi(\mu, \epsilon + [\lambda - \nu])$, so $\dim E^x v = |\tilde{\mu}|$.
2. $\bigsqcup_m (\mathcal{B}^{\tilde{\mu}^m} \cap V_m)$ is a colored basis for $F^x v$. In particular, $F^x v$ is colored and x^n -stable, with $\xi_m(F^x v) = \sum_{i=1}^{l(\lambda)} \left\lceil \frac{\mu_i^m}{n} \right\rceil$, so $\dim(F^x v) = \sum_{m=0}^{n-1} \sum_{i=1}^{l(\lambda)} \left\lceil \frac{\mu_i^m}{n} \right\rceil$.

Proof. The proof of (2) should be clear once we have proved (1). Since $x \in E^x$ it is clear that $E^x v$ is x -stable. Now, $y_{k,k,\lambda_k} v = \sum a_{i,j} y_{k,k,\lambda_k} v_{i,j} = \sum a_{k,j} v_{k,j}$. Set $v_k = \sum a_{k,j} v_{k,j}$.

It is clear, then, that $E^x v = E^x v_1 + \cdots + E^x v_{l(\lambda)}$. So, we may assume that $v = v_k$ lives in a single Jordan block.

Since $E^x v$ is a vector space, we may assume that $a_{k,\mu_k} = 1$. Now, $y = y_{k,k,\lambda_k} - a_{k,\mu_{k-1}} y_{k,k,\lambda_k-1}$ is in E^x . But yv has no $v_{k,\mu_{k-1}}$ -component. By a similar construction, we may successively eliminate each component of v_k , leaving v_{k,μ_k} . In other words, we have shown that $v_{k,\mu_k} \in E^x v$. But then by x -stability we have $v_{k,j} \in E^x v$ for each $1 \leq j \leq \mu_k$. This also shows that some subset of \mathcal{B} is a basis of $E^x v$.

Now, suppose that $v_{i,j} \in E^x v$, with $j > \mu_i$. This occurs precisely if there is a $k \neq i$ with a choice of a, b such that $v_{i,j} = y_{k,a,b} v_{k,\mu_k} = v_{a,b+\mu_k-\lambda_k}$ and $1 \leq b \leq \min\{\lambda_a, \lambda_k\}$. Obviously, we must have $a = i$ and $j = b + \mu_k - \lambda_k$, with $1 \leq b \leq \min\{\lambda_i, \lambda_k\}$. Substituting, we have $1 \leq j + \lambda_k - \mu_k \leq \min\{\lambda_i, \lambda_k\}$. If $k < i$ then we have $j + \lambda_k - \mu_k \leq \lambda_i$, or $j \leq \lambda_i - (\lambda_k - \mu_k)$. If $k > i$ then we have $j + \lambda_k - \mu_k \leq \lambda_k$, or $j \leq \mu_k$. Therefore, $v_{i,j} \in E^x v$ if and only if $j \leq \max(\{\mu_k \mid k \geq i\} \cup \{\lambda_i - (\lambda_k - \mu_k) \mid k \leq i\})$. In other words, $j \leq \tilde{\mu}_i$.

The remainder of the claims follow immediately. \square

We pause here to observe that propositions 5.2.4 and 4.3.1 give an alternate proof that the striped n -bipartition associated to \mathcal{O} is unique. Proposition 5.2.4 gives a canonical interpretation of $(\lambda, \epsilon, \tilde{\mu})$ that shows it is an orbit invariant. Proposition 4.3.1 shows that any striped n -bipartition corresponding to the orbit must be equal to $\bar{\rho}(\lambda, \epsilon, \tilde{\mu})$, hence is completely determined. Similarly, if (λ, ϵ, μ) is a striped n -bipartition corresponding to (v, x) and $W = \mathbb{F}[x](F^x(v))$ then $x|_W$ has colored Jordan type $(\mu, \epsilon + [\lambda - \mu])$.

Corollary 5.2.5. *If $(v, x) \in \tilde{V} \times \mathcal{N}$ corresponds to the striped n -bipartition (λ, ϵ, μ) then*

$$\dim F^x v = \sum_{i=1}^{l(\lambda)} \left\lceil \frac{\mu_i}{n} \right\rceil.$$

Corollary 5.2.6. *Let (λ, ϵ, μ) be a striped n -bipartition with $(\lambda, \epsilon, \tilde{\mu}) = \bar{\rho}(\lambda, \epsilon, \mu)$ and set $\tilde{\nu} = \lambda - \tilde{\mu}$ and $\tilde{\epsilon} = \epsilon + [\nu]$. If $(v, x) \in \tilde{V} \times \mathcal{N}$ then $(v, x) \in \mathcal{O}_{\lambda, \epsilon, \mu}$ if and only if $x|_{E^x v}$ has colored Jordan type $(\tilde{\mu}, \tilde{\epsilon})$ and $x|_{V/E^x v}$ has colored Jordan type $(\tilde{\nu}, \epsilon)$.*

Proof. The proposition, plus lemma 4.2.5, tells us the colored Jordan type of $x|_{E^x v}$ and of $x|_{V/E^x v}$. Conversely, if $x|_{E^x v}$ and of $x|_{V/E^x v}$ are determined, there is only one way to pair them to get a colored bipartition, so the striped n -bipartition is determined, as well. \square

Corollary 5.2.7. *If (λ, ϵ, μ) is a striped n -bipartition and s_k is as given in definition 3.3.6 then*

$$\dim \mathcal{O}_x = \sum_i (\dim V_i)^2 - \sum_{k=1}^{l(\lambda)} s_{\lambda_k}(x)(\epsilon_k),$$

$$\dim \mathcal{O}_{v,x} = \sum_i (\dim V_i)^2 - \sum_{k=1}^{l(\lambda)} s_{\lambda_k}(x)(\epsilon_k) + \sum_{i=1}^{l(\lambda)} \left\lceil \frac{\mu_i}{n} \right\rceil.$$

Corollary 5.2.8. *If $n = 1$ and (λ, ϵ, μ) is a striped 1-bipartition (bipartition) then*

$$\dim \mathcal{O}_{\lambda,\epsilon} = 2 \binom{\dim V}{2} - 2\eta(\lambda),$$

$$\dim \mathcal{O}_{\lambda,\epsilon,\mu} = 2 \binom{\dim V}{2} - 2\eta(\lambda) + |\mu|.$$

Proof. If $n = 1$ then $F^x = E^x$. □

Once again, we recall that if $n = 2$ then we customarily use $+$ and $-$ in place of 0 and 1, respectively, as the colors that decorate our partitions. So, by a signed 2-bipartition of signature (p, q) we simply mean a striped 2-bipartition that has p boxes labeled with $+$ and q boxes labeled with $-$.

Corollary 5.2.9. *If $n = 2$ then orbits in $K \setminus (\tilde{V} \times \mathcal{N})$ are parametrized by striped 2-bipartitions. If (λ, ϵ, μ) is a striped 2-bipartition then*

$$\dim \mathcal{O}_{\lambda,\epsilon} = \binom{\dim V}{2} - \eta(\lambda),$$

$$\dim \mathcal{O}_{\lambda,\epsilon,\mu} = \binom{\dim V}{2} - \eta(\lambda) + \sum_{i=1}^{l(\lambda)} \left\lceil \frac{\mu_i}{2} \right\rceil.$$

CHAPTER 6

NILPOTENT ORBIT CLOSURES

We construct an explicit resolution of singularities for the closure of each nilpotent orbit in \mathcal{N} . From this construction we develop multiple combinatorial descriptions of the closure order in $K \backslash \mathcal{N}$, with the goal of understanding the closure order in $K \backslash (\tilde{V} \times \mathcal{N})$.

6.1 Resolution of singularities

Since K acts on \mathcal{N} with finitely many orbits, the orbits are partially ordered by the rule $\mathcal{O}_y \leq \mathcal{O}_x$ if and only if $\mathcal{O}_y \subset \overline{\mathcal{O}_x}$. Our goal in this section is to begin to understand the closure order in $K \backslash \mathcal{N}$. We begin by constructing a convenient partial flag variety and a natural generalization.

If $(v, x) \in \tilde{V} \times \mathcal{N}$ then we define

$$W_k^{v,x} = \begin{cases} x^{\mu_1-k} (E^x v) & \text{if } k < \mu_1, \\ E^x v & \text{if } k = \mu_1, \\ (x^{k-\mu_1})^{-1} (E^x v) & \text{if } k > \mu_1. \end{cases}$$

If (λ, ϵ, μ) is the minimal colored bipartition corresponding to (v, x) and we draw a mark-aligned diagram for (λ, ϵ, μ) then we can think of $W_k^{v,x}$ as the span of the first k columns of the diagram.

Lemma 6.1.1. *$W_k^{v,x}$ is colored and $\xi(W_k^{v,x})(m)$ is the number of boxes of color m in the first k columns of the mark-aligned diagram of the minimal colored bipartition (λ, ϵ, μ) corresponding to (v, x) . In particular, if $(w, y) \in \mathcal{O}_{v,x}$ then $\xi(W_k^{v,x}) = \xi(W_k^{w,y})$.*

Definition 6.1.2. If (λ, ϵ, μ) is a marked colored partition and $(v, x) \in \mathcal{O}_{\lambda, \epsilon, \mu}$ then, in the notation of lemma 2.2.7, we define

$$\begin{aligned} \mathcal{F}_{\lambda, \epsilon, \mu} &= X_{\xi(W_1^{v,x}), \dots, \xi(W_{\lambda_1}^{v,x})}, \\ \widehat{\mathcal{F}}_{\lambda, \epsilon, \mu} &= \{(y, (W_k)) \in \mathcal{N} \times \mathcal{F}_{\lambda, \epsilon, \mu} \mid yW_k \subset W_{k-1}\}. \end{aligned}$$

Theorem 6.1.3. *If (λ, ϵ, μ) is a marked colored partition then the natural projection $\psi : \widehat{\mathcal{F}}_{\lambda, \epsilon, \mu} \rightarrow \mathcal{N}$ is a resolution of singularities for $\overline{\mathcal{O}_{\lambda, \epsilon}}$.*

Proof. We observe, first of all, that if $(v, x) \in \mathcal{O}_{\lambda, \epsilon, \mu}$ then $(x, (W_k^{v, x})) \in \widehat{\mathcal{F}}_{\lambda, \epsilon, \mu}$. Therefore, $\widehat{\mathcal{F}}_{\lambda, \epsilon, \mu}$ is nonempty and $x = \psi(x, (W_k^{v, x}))$, so we see that the image of ψ contains $\mathcal{O}_{\lambda, \epsilon}$. Note also that ψ is clearly K -equivariant, so it induces a map of K -orbits.

There is also a natural projection $\widehat{\mathcal{F}}_{\lambda, \epsilon, \mu} \rightarrow \mathcal{F}_{\lambda, \epsilon, \mu}$. This map is a K -equivariant vector bundle. The fact that $\mathcal{F}_{\lambda, \epsilon, \mu}$ is a nonsingular irreducible variety ensures that $\widehat{\mathcal{F}}_{\lambda, \epsilon, \mu}$ is nonsingular and irreducible.

Now, ψ extends to a projection $\mathcal{N} \times \mathcal{F}_{\lambda, \epsilon, \mu} \rightarrow \mathcal{F}_{\lambda, \epsilon, \mu}$. Since $\mathcal{F}_{\lambda, \epsilon, \mu}$ is a projective variety, this extended map is proper. But $\widehat{\mathcal{F}}_{\lambda, \epsilon, \mu}$ is a closed subvariety of $\mathcal{N} \times \mathcal{F}_{\lambda, \epsilon, \mu}$, so $\psi(\widehat{\mathcal{F}}_{\lambda, \epsilon, \mu})$ is a K -stable irreducible closed subvariety of \mathcal{N} . We conclude that there is a single K -orbit $\mathcal{O} = \mathcal{O}_{\alpha, \beta}$ such that $\psi(\widehat{\mathcal{F}}_{\lambda, \epsilon, \mu}) = \overline{\mathcal{O}}$.

We know that $\mathcal{O}_{\lambda, \epsilon} \subset \overline{\mathcal{O}}$ and $K \subset G = GL(V)$, so $\mathcal{O}_{\lambda} = G \cdot \mathcal{O}_{\lambda, \epsilon} \subset G \cdot \overline{\mathcal{O}} \subset \overline{G \cdot \mathcal{O}} = \overline{\mathcal{O}_{\alpha}}$. On the other hand, if we set $\nu = \lambda - \mu$ then the definitions of $\psi_{\mu; \nu}$ and $\widehat{\mathcal{F}}_{\mu; \nu}$ in [1] show that $\overline{\mathcal{O}} = \psi(\widehat{\mathcal{F}}_{\lambda, \epsilon, \mu}) \subset \psi_{\mu; \nu}(\widehat{\mathcal{F}}_{\mu; \nu}) = \overline{\mathcal{O}_{\lambda}}$. Therefore, $\mathcal{O}_{\alpha} = G \cdot \mathcal{O} \subset G \cdot \overline{\mathcal{O}} \subset G \cdot \overline{\mathcal{O}_{\lambda}} = \overline{\mathcal{O}_{\lambda}}$, hence $\mathcal{O}_{\alpha} \subset \overline{\mathcal{O}_{\lambda}}$. Since $\mathcal{O}_{\alpha} \subset \overline{\mathcal{O}_{\lambda}}$ and $\mathcal{O}_{\lambda} \subset \overline{\mathcal{O}_{\alpha}}$, we conclude that $\mathcal{O}_{\alpha} = \mathcal{O}_{\lambda}$, so $\alpha = \lambda$.

Consider the particular case $\mu \leq 0$. If $(v, x) \in \mathcal{O}_{\lambda, \epsilon, \mu}$ then $v = 0$, so $W_k^{v, x} = \ker x^k$ and $\xi(W_k^{v, x}) = s_k(\lambda, \epsilon)$. Since $\psi(\widehat{\mathcal{F}}_{\lambda, \epsilon, \mu})$ is closed and contains $\mathcal{O}_{\lambda, \epsilon}$, we know that $\overline{\mathcal{O}_{\lambda, \epsilon}} \subset \psi(\widehat{\mathcal{F}}_{\lambda, \epsilon, \mu})$. Therefore, if $y \in \overline{\mathcal{O}_{\lambda, \epsilon}}$ then there is a partial flag (W_k) such that $(y, (W_k)) \in \widehat{\mathcal{F}}_{\lambda, \epsilon, \mu}$. By conjugation, possibly choosing a different representative of \mathcal{O}_y , we may assume that $W_k = W_k^{v, x} = \ker x^k$. Since $y \ker x^k \subset \ker x^{k-1}$, we conclude inductively that $y^k \ker x^k \subset \{0\}$. That is, $\ker x^k \subset \ker y^k$, so $\xi(\ker x^k) \leq \xi(\ker y^k)$.

By the above paragraph, since $\mathcal{O}_{\lambda, \epsilon} \subset \overline{\mathcal{O}_{\alpha, \beta}}$ we must have $s_k(\lambda, \epsilon) \geq s_k(\alpha, \beta)$. But $|s_k(\lambda, \epsilon)| = \sum_{i=1}^k \lambda^i = \sum_{i=1}^k \alpha^i = |s_k(\alpha, \beta)|$, so $s_k(\lambda, \epsilon) = s_k(\alpha, \beta)$ and we conclude that $\psi(\widehat{\mathcal{F}}_{\lambda, \epsilon, \mu}) = \overline{\mathcal{O}} = \overline{\mathcal{O}_{\lambda, \epsilon}}$.

The last thing to check is that $\psi : (\psi^{-1}(\mathcal{O}_{\lambda, \epsilon}))$ is an isomorphism, but this is an immediate consequence of the construction in [1]. \square

Corollary 6.1.4. *If $y \in \overline{\mathcal{O}_x}$ then $s_k(x) \leq s_k(y)$ for each positive integer k .*

Proof. This was proved in the course of proving the theorem. \square

Definition 6.1.5. If (λ, ϵ) and (α, β) are colored partitions of the same signature then we say that $(\alpha, \beta) \leq (\lambda, \epsilon)$ if $s_k(\alpha, \beta) \geq s_k(\lambda, \epsilon)$ for each k .

We remark here that definition 6.1.2 does not strictly require v to be colored. The resulting constructions are still smooth and appropriately colored. Furthermore, theorem 6.1.3 still holds. We may refer to these constructions as $\mathcal{F}_{v,x}$ and $\widehat{\mathcal{F}}_{v,x}$.

6.2 The closure order

Proposition 6.2.1. *Fix $(v, x) \in \widetilde{V} \times \mathcal{N}$ with minimal colored bipartition (λ, ϵ, μ) and let $y \in \mathcal{N}$ satisfy $s_k(y) \geq s_k(x)$ for each positive integer k . If $\mathcal{B} = \{v_{i,j}\}$ is a colored Jordan basis of type (λ', ϵ') for y then there is a chain $0 = W_0 \subset W_1 \subset \cdots \subset W_{\lambda_1}$ of subspaces such that*

1. $\xi(W_k) = \xi(W_k^{v,x})$,
2. $yW_k \subset W_{k-1}$,
3. $\mathcal{B} \cap W_k$ is a basis for W_k .

Proof. We begin by defining $f_k = \xi(W_k^{v,x})$. It is clear that $f_k \leq s_k(x) \leq s_k(y)$, so we may select a set $Z \subset \mathbb{N}$ such that $W_1 = \langle \{v_{i,1} \mid i \in Z\} \rangle$ satisfies $\xi(W_1) = f_1$. We may further assume that $\sum_{i \in Z} \lambda_i$ is maximal. We also choose a colored Jordan basis $\mathcal{B}_x = \{w_{i,j}\}$ for x .

In order to apply induction, we need to show that if $\bar{x} : V/W_1^{v,x} \rightarrow V/W_1^{v,x}$ and $\bar{y} : V/W_1 \rightarrow V/W_1$ are the induced maps then $s_k(\bar{y}) \geq s_k(\bar{x})$. Let

$$Z_x = \{i \mid w_{i,1} \in W_1^{v,x} \subset \ker x\}.$$

It should be clear that $\mathcal{B}' = \{\bar{v}_{i,j} \mid j > 1 \text{ if } i \in Z\}$ and $\mathcal{B}'_x = \{\bar{w}_{i,j} \mid j > 1 \text{ if } i \in Z_x\}$ are colored Jordan bases for \bar{x} and \bar{y} , respectively. It should also be clear that

$$\{\bar{v}_{i,j} \mid 2 \leq j \leq k\} \cup \{\bar{v}_{i,1} \mid i \notin Z\} \cup \{\bar{v}_{i,k+1} \mid i \in Z\}$$

is a basis for $\ker \bar{y}^k$. A simple calculation shows that for fixed m we have

$$s_k(\bar{x})(m) = s_k(x)(m) - f_1(m) + \#\{i \in Z_x \mid \lambda_i \geq k+1, \epsilon_i + [\lambda_i - (k+1)] = m\},$$

$$s_k(\bar{y})(m) = s_k(y)(m) - f_1(m) + \#\{i \in Z \mid \lambda'_i \geq k+1, \epsilon'_i + [\lambda'_i - (k+1)] = m\}.$$

The last term in each sum is simply a count of the boxes of color m in row $k+1$ that get shifted to the left when x and y descend to \bar{x} and \bar{y} .

Suppose that $s_k(\bar{x})(m) > s_k(\bar{y})(m)$ for some k, m . Because $s_k(x)(m) \leq s_k(y)(m)$, the above equations force $\#\{i \in Z_x \mid \lambda_i \geq k+1, \epsilon_i + [\lambda_i - (k+1)] = m\} > \#\{i \in Z \mid \lambda'_i \geq$

$k+1, \epsilon'_i + [\lambda'_i - (k+1)] = m\}$. It is obvious that $\#\{i \in Z \mid \lambda'_i \geq k+1, \epsilon'_i + [\lambda'_i - (k+1)] = m\} \leq \#\{i \in \mathbb{N} \mid \lambda'_i \geq k+1, \epsilon'_i + [\lambda'_i - (k+1)] = m\} = s_{k+1}(y)(m) - s_k(y)(m)$.

Suppose further that $\#\{i \in Z \mid \lambda'_i \geq k+1, \epsilon'_i + [\lambda'_i - (k+1)] = m\} < s_{k+1}(y)(m) - s_k(y)(m)$. That is, there is a box of color m in column $k+1$ of y (say, $v_{i_0, k+1}$, $i_0 \notin Z$) that doesn't share a Jordan block with an element of W_1 . Then by construction we have

$$\begin{aligned} \#\{i \in Z \mid \epsilon' + [\lambda' - 1] = m + [k]\} &= f_1(m + [k]) \\ &= \#\{i \in Z_x \mid \epsilon' + [\lambda' - 1] = m + [k]\} \\ &\geq \#\{i \in Z_x \mid \lambda_i \geq k+1, \epsilon_i + [\lambda_i - 1] = m + [k]\} \\ &> \#\{i \in Z \mid \lambda'_i \geq k+1, \epsilon'_i + [\lambda'_i - (k+1)] = m\}. \end{aligned}$$

That is, there is an element $v_{i_1, 1} \in W_1$ such that $\chi(v_{i_1, 1}) = m + [k]$, but $\lambda_{i_1} < k+1 \leq \lambda_{i_0}$. By removing i_1 from Z and replacing it with i_0 , we have increased $\sum_{i \in Z} \lambda_i$, violating maximality. We conclude that $\#\{i \in Z \mid \lambda'_i \geq k+1, \epsilon'_i + [\lambda'_i - (k+1)] = m\} = s_{k+1}(y)(m) - s_k(y)(m)$. Therefore, $s_k(\bar{y})(m) = s_k(y)(m) - f_1(m) + s_{k+1}(y)(m) - s_k(y)(m) = s_{k+1}(y)(m) - f_1(m)$.

Clearly, $s_k(\bar{x})(m) \leq s_{k+1}(x)(m) - f_1(m)$, so we have the following:

$$\begin{aligned} s_{k+1}(x)(m) &\geq s_k(\bar{x})(m) + f_1(m) \\ &> s_k(\bar{y})(m) + f_1(m) \\ &= s_{k+1}(y)(m), \end{aligned}$$

a contradiction. We conclude that $s_k(\bar{y}) \geq s_k(\bar{x})$ for each k .

By induction, then, we can construct a chain

$$0 = W_1/W_1 \subset W_2/W_1 \subset \cdots \subset W_{\lambda_1}/W_1 = V/W_1$$

such that $\xi(W_k/W_1) = f_{k+1} - f_1$ and $\bar{y}(W_k/W_1) \subset W_{k-1}/W_1$, and $(\mathcal{B}/W_1) \cap (W_k/W_1)$ is a basis for \overline{W}_k . We simply lift this chain from V/W_1 to V . That is, if $k > 1$ then $W_k = \langle \{v_{i,j} \in \mathcal{B} \mid \bar{v}_{i,j} + W_1 \in W_k/W_1\} \rangle$. \square

Corollary 6.2.2. *If $x, y \in \mathcal{N}$ have colored Jordan types (λ, ϵ) and (α, β) , respectively, then the following are equivalent:*

1. $\mathcal{O}_y \subset \overline{\mathcal{O}_x}$,
2. $y \in \overline{\mathcal{O}_x}$,

3. For each $v \in \tilde{V}$ there exists a chain (W_k) of colored subspaces such that for each $k \in \mathbb{N}$ the following are satisfied:

(a) $\xi(W_k) = \xi(W_k^{v,x})$,

(b) $yW_k \subset W_{k-1}$.

4. $s_k(\alpha, \beta) \geq s_k(\lambda, \epsilon)$ for each k ,

5. $\bar{s}_k(\alpha, \beta) \geq \bar{s}_k(\lambda, \epsilon)$ for each k ,

6. For each $v \in \tilde{V}$ and each colored Jordan basis $\mathcal{B} = \{v_{i,j}\}$ for y there is a function $\zeta : \mathcal{B} \rightarrow \mathbb{N}$ such that

(a) $\zeta(v_{i,j}) < \zeta(v_{i,j+1})$ whenever $1 \leq j < \lambda_i$,

(b) $\xi(\zeta^{-1}(\{1, \dots, k\})) = \xi(W_k^{v,x})$.

7. For each $v \in \tilde{V}$ there is a sequence of markings $\mu^{(k)}$ of (α, β) such that $\mu^{(k)} < \mu^{(k+1)}$ and $\xi(\{v_{i,j} \mid 1 \leq j \leq \mu_i^{(k)}\}) = \xi(W_k^{v,x})$.

Proof.

(1) \iff (2).

This is a standard result.

(1) \iff (3).

This follows immediately from the fact that $\widehat{\mathcal{F}}_{\lambda, \epsilon, \mu}$ is a resolution of singularities for \mathcal{O}_x .

(1) \implies (4).

This is lemma 6.1.4

(4) \implies (3).

This is proposition 6.2.1.

(4) \iff (5).

Lemma 3.3.8 implies that $\bar{s}_k(y) - \bar{s}_k(x) = s_k(y) - s_k(x)$.

(4) \implies (6).

Let (W_k) be the partial flag constructed in proposition 6.2.1 and set

$$\zeta(v) = \min\{k \mid v \in W_k\}.$$

(6) \implies (3).

Set $W_k = \zeta^{-1}(\{1, \dots, k\})$.

(6) \implies (7).

Set $\mu_i^{(k)} = \max\{j \in \mathbb{Z}^{\geq 0} \mid \zeta(v_{i,j}) \leq k\}$.

(7) \implies (6).

Set $\zeta(v_{i,j}) = \min\{k \in \mathbb{N} \mid j \leq \mu_i^{(k)}\}$. □

Lemma 6.2.3. *If $(x, (W_k)) \in \widehat{\mathcal{F}}_{\lambda, \epsilon, \mu}$ then $W_k = W_k^{v, x}$.*

Proof. This follows immediately from Proposition 3.3 in [1]. □

Now that we have shown that $\widehat{\mathcal{F}}_{\lambda, \epsilon, \mu}$ is a resolution of singularities for $\overline{\mathcal{O}}_{\lambda, \epsilon}$, we can provide an alternative formula for $\dim \mathcal{O}_{\lambda, \epsilon}$.

Corollary 6.2.4. *If $x \in \mathcal{O}_{\lambda, \epsilon}$ then*

$$\begin{aligned} \dim \mathcal{O}_{\lambda, \epsilon} &= \sum_{m=1}^n (\dim V_m)^2 - \sum_{m=1}^n \sum_{k=1}^{\lambda_1} (s_k(m) - s_{k-1}(m))^2 \\ &\quad + \sum_{m=1}^n \sum_{k=1}^{\lambda_1} (s_k(m) - s_{k-1}(m))(s_{k-1}(m+1) - s_{k-1}(m)) \end{aligned}$$

Proof. The first two terms are the dimension of $\mathcal{F}_{\lambda, \epsilon, \mu}$. The third sum is the rank of $\widehat{\mathcal{F}}_{\lambda, \epsilon, \mu}$ as a vector bundle over $\mathcal{F}_{\lambda, \epsilon, \mu}$. □

Note that in the case $n = 1$ the sums over m consist of a single term and $m + 1 \equiv m \pmod{n}$, so the third sum vanishes, leaving the classical formula for $\dim \mathcal{O}_{\lambda}$.

Fix the flag $(W_k) = (W_k^{v, x}) \in \mathcal{F}_{\lambda, \epsilon, \mu}$ and define

$$Z = \pi^{-1}(W_k^{v, x}) = \{y \in \mathcal{N} \mid (y, (W_k)) \in \widehat{\mathcal{F}}_{\lambda, \epsilon, \mu}\}.$$

Draw the left-justified colored diagram for x with corresponding colored Jordan basis $\mathcal{B} = \{v_{i,j}\}$. The condition that y preserves the flag simply means that a vector represented by a box in the diagram must be sent to a box in the same column or to the left. That $y \in \mathcal{N}$ means that a box of color $[i]$ must be sent to a box of color $[i + 1]$. Therefore,

$$\begin{aligned} \dim Z &= \sum_{i=1}^{l(\lambda)} \sum_{j=1}^{\lambda_i} \#\{(a, b) \mid v_{a,b} \in \mathcal{B}, b \leq j, \chi(v_{a,b}) = \chi(v_{i,j}) + [1]\} \\ &= \sum_{i=1}^{l(\lambda)} \sum_{j=1}^{\lambda_i} \dim \ker x^j \cap V_{\chi(v_{i,j}) + [1]} = \dim \mathcal{O}_x. \end{aligned}$$

6.3 Colored covering relations

If (λ, ϵ) and (α, β) are colored partitions of the same signature then we say that (λ, ϵ) *covers* (α, β) if $(\lambda, \epsilon) > (\alpha, \beta)$ and there is no colored partition (γ, δ) such that $(\lambda, \epsilon) > (\gamma, \delta) > (\alpha, \beta)$. Our goal for the present is to determine combinatorial criteria for building covers.

Definition 6.3.1. If (λ, ϵ) is a colored partition then a *right move* on (λ, ϵ) is a triple (i, j, t) of positive integers such that

1. $i < j$
2. $\lambda_j + t < \lambda_i$
3. $[t] = \epsilon_j - \epsilon_i$.

If we apply (i, j, t) to (λ, ϵ) we obtain a new colored partition (λ', ϵ') defined by

$$\lambda'_k = \begin{cases} \lambda_i - t & k = i \\ \lambda_j + t & k = j \\ \lambda_k & \text{otherwise.} \end{cases} \quad \epsilon'_k = \begin{cases} \epsilon_j & k = i \\ \epsilon_i & k = j \\ \epsilon_k & \text{otherwise.} \end{cases}$$

Similarly, a *left move* on (λ, ϵ) is a triple (i, j, t) of positive integers such that

1. $i < j$
2. $\lambda_j + t < \lambda_i$
3. $[t] = [\lambda_i - \lambda_j] + \epsilon_i - \epsilon_j$.

If we apply (i, j, t) to (λ, ϵ) we obtain a new colored partition (λ', ϵ') defined by

$$\lambda'_k = \begin{cases} \lambda_i - t & k = i \\ \lambda_j + t & k = j \\ \lambda_k & \text{otherwise.} \end{cases} \quad \epsilon'_k = \begin{cases} \epsilon_i & k = i \\ \epsilon_j & k = j \\ \epsilon_k & \text{otherwise.} \end{cases}$$

Visually, to apply a right move is to move the rightmost t blocks from row i to the right end of row j . A left move is to move the leftmost t blocks from row i to the left end of row j . Note that (λ', ϵ') is not strictly a colored partition, but we need only reorder the rows. Note also that if $\lambda_j + t < \lambda_i$ then $\lambda_i \geq \lambda_j + 2$. Lastly, we point out that the case $\lambda_0 = 0$ is prohibited but $\lambda_j = 0$ is not. In fact, this is precisely the context in which it is important that there be many i with $\lambda_i = 0$.

Lemma 6.3.2. *To each left move there is an equivalent right move and vice versa. That is, if (λ', ϵ') is constructed from (λ, ϵ) by application of a move (left or right) (i, j, t) then there is a move of the opposite type that also produces a colored partition equivalent to (λ', ϵ') .*

Proof. $(i, j, \lambda_i - \lambda_j - t)$ is the corresponding move. To see the equivalence, we just need to apply both moves but swap rows i and j on one of the resulting diagrams. This is because $\lambda_j + (\lambda_i - \lambda_j - t) = \lambda - t$ and $\lambda_i - (\lambda_i - \lambda_j - t) = \lambda_j + t$.

If, however, $[\lambda_i] = [\lambda_j]$ and $\epsilon_i = \epsilon_j$ then (i, j, t) is another such corresponding move. That is, in this case the left and right moves are indistinguishable. \square

Lemma 6.3.3. *If (λ, ϵ) is a colored partition and (i, j, t) is a move (right or left) then (λ', ϵ') obtained as above is row-equivalent to a colored partition of the same signature as (λ, ϵ) and $(\lambda', \epsilon') < (\lambda, \epsilon)$.*

Proof. This can be carefully proved using a function ζ or by simply observing that a right move always moves blocks down and left, so can only increase s_k . \square

Our goal is to show that right and left moves generate the closure order. The lemma shows that, for the purposes of proof, we can restrict our attention to right moves. Alternatively, note that if $t \leq \frac{1}{2}(\lambda_i - \lambda_j)$ then $\lambda'_j \leq \lambda'_i$, so we don't need to swap rows i and j . On the other hand, if $t > \frac{1}{2}(\lambda_i - \lambda_j)$ then $(\lambda_i - \lambda_j) - t < \frac{1}{2}(\lambda_i - \lambda_j)$, so the opposite move does not require swapping rows i and j . Therefore, the lemma can also be interpreted to show that if we allow both left and right moves then we can arrange to minimize row swapping.

Lemma 6.3.4. *If (λ, ϵ) and (α, β) are colored partitions and k is an integer then*

$$s_k((\lambda, \epsilon) \cup (\alpha, \beta)) = s_k(\lambda, \epsilon) + s_k(\alpha, \beta).$$

Lemma 6.3.5. *If (λ, ϵ) and (α, β) are colored partitions of the same signature and there are integers i and j such that $\lambda_i = \alpha_j$ and $\epsilon_i = \beta_j$ then $(\alpha, \beta) < (\lambda, \epsilon)$ if and only if $\Delta_j(\alpha, \beta) < \Delta_i(\lambda, \epsilon)$.*

Proof. This is a simple application of 6.3.5. \square

Proposition 6.3.6. *If (λ, ϵ) is a colored partition and (i, j, t) is a (right) move on (λ, ϵ) with result (λ', ϵ') then $(\lambda', \epsilon') < (\lambda, \epsilon)$.*

Proof. By lemma 6.3.4, it is sufficient to assume that $l(\lambda) \leq 2$. From here it is a simple exercise. \square

Lemma 6.3.7. *Let (i, j, t) be a move on (λ, ϵ) with result (λ', ϵ') . If (λ, ϵ) covers (λ', ϵ') then either $t \leq n$ or $\lambda_i - \lambda_j - t \leq n$.*

Proof. It is enough to assume that (i, j, t) is a right move and that $t \leq \frac{1}{2}(\lambda_i - \lambda_j)$. Suppose that $t > n$. If $\epsilon_i = \epsilon_j$ then we can apply the following right moves in succession: (i, j, n) , $(i, j, t - n)$. If $\epsilon_i \neq \epsilon_j$ then apply the following moves in succession: $(i, j, \langle t \rangle)$, $(i, j, n - \langle t \rangle)$, $(i, j, t - n)$. It is a simple exercise to verify that these sequences constitute valid moves and that the end result is equivalent to (i, j, t) . \square

Lemma 6.3.8. *If $(\lambda, \beta) \leq (\lambda, \epsilon)$ then (λ, β) and (λ, ϵ) are equivalent.*

Proof. Since $(\lambda, \beta) \leq (\lambda, \epsilon)$ we have $s_k(\lambda, \epsilon) \leq s_k(\lambda, \beta)$. But

$$|s_k(\lambda, \epsilon)| = \sum_{i=1}^k \lambda_i^t = |s_k(\lambda, \beta)|,$$

so $s_k(\lambda, \epsilon) = s_k(\lambda, \beta)$. \square

Lemma 6.3.9. *Let $(\alpha, \beta) < (\lambda, \epsilon)$ and let $\mathcal{B} = \{v_{i,j}\}$ be a colored Jordan basis for $y \in \mathcal{O}_{\alpha,\beta}$. Let $x \in \mathcal{O}_{\lambda,\epsilon}$, $v = 0$ and let $\zeta : \mathcal{B} \rightarrow \mathbb{N}$ be as in (6) of corollary 6.2.2. Then*

1. *For each (i, j) satisfying $1 \leq j \leq \lambda_i$ we have $\zeta(v_{i,j}) \geq j$.*

2.
$$\sum_{i=1}^{l(\alpha)} \sum_{j=1}^{\lambda_i} (\zeta(v_{i,j}) - j) = \eta(\lambda^t) - \eta(\alpha^t) > 0.$$

Proof.

1. $\zeta(v_{i,1}) > 0$, so $\zeta(v_{i,1}) \geq 1$. Inductively, $\zeta(v_{i,j}) > \zeta(v_{i,j-1})$, so

$$\zeta(v_{i,j}) \geq \zeta(v_{i,j-1}) + 1 \geq (j-1) + 1 = j.$$

2. We just evaluate and simplify the formula:

$$\begin{aligned}
\sum_i^{l(\alpha)} \sum_j^{\alpha_i} (\zeta(v_{i,j}) - j) &= \sum_i^{l(\alpha)} \sum_j^{\alpha_i} \zeta(v_{i,j}) - \sum_i^{l(\alpha)} \sum_j^{\alpha_i} j \\
&= \sum_{k=1}^{\infty} k \cdot \#\{(i,j) \mid \zeta(v_{i,j}) = k\} - \sum_i^{l(\alpha)} \sum_j^{\alpha_i-1} j \\
&= \sum_{k=1}^{\infty} k \lambda_i^t - \sum_i^{l(\alpha)} \alpha_i - \sum_i^{l(\alpha)} \sum_j^{\alpha_i-1} j \\
&= \sum_{k=1}^{\infty} \lambda_i^t + \sum_{k=1}^{\infty} (k-1) \lambda_i^t - |\alpha| - \sum_i^{l(\alpha)} \binom{\alpha_i}{2} \\
&= |\lambda| + \eta(\lambda^t) - |\alpha| - \eta(\alpha^t) \\
&= \eta(\lambda^t) - \eta(\alpha^t).
\end{aligned}$$

Lastly, because $(\alpha, \beta) < (\lambda, \epsilon)$ we know there is an integer k_0 such that $|s_k(\lambda, \epsilon)| < |s_k(\lambda, \beta)|$. Therefore, there must be some (i, j) such that $\zeta(v_{i,j}) > k \geq j$. \square

Proposition 6.3.10. *If (λ, ϵ) and (α, β) colored partitions and $(\alpha, \beta) < (\lambda, \epsilon)$ then there is a sequence of right moves beginning with (λ, ϵ) and ending with (α, β) .*

Proof. Fix a colored Jordan basis $\{v_{i,j}\}$ for $y \in \mathcal{O}_{\alpha, \beta}$ and let ζ be as in lemma 6.3.9. As a notational convention, we declare that $\zeta(v_{i,0}) = 0$.

By hypothesis, $(\alpha, \beta) \neq (\lambda, \epsilon)$, so $\sum_{i,j} \zeta(v_{i,j}) - j > 0$. Therefore, there exists a pair (i_0, j_0) such that $\zeta(v_{i_0, j_0}) > j$. More specifically, there must be a pair (i_0, j_0) with $j_0 \geq 1$ and $\zeta(v_{i_0, j_0}) \geq \zeta(v_{i_0, j_0-1}) + 2$. Among all such pairs, there is one with $\zeta(v_{i_0, j_0})$ maximal. The number of elements $w \in \mathcal{B}$ satisfying $\chi(w) = \chi(v_{i_0, j_0}) + [1]$ and $\zeta(w) = \zeta(v_{i_0, j_0}) - 1$ must be at least as large as the number of elements $u \in \mathcal{B}$ satisfying $\chi(u) = \chi(v_{i_0, j_0})$ and $\zeta(u) = \zeta(v_{i_0, j_0})$. Therefore, there must be a pair (i_1, j_1) such that $\chi(v_{i_1, j_1}) = \chi(v_{i_0, j_0}) + [1]$, $\zeta(v_{i_1, j_1}) = \zeta(v_{i_0, j_0}) - 1$, and either $j_1 = \alpha_{i_1}$ or $\zeta(v_{i_1, j_1+1}) \neq \zeta(v_{i_0, j_0})$. If $\zeta(v_{i_1, j_1+1}) \neq \zeta(v_{i_0, j_0})$ then $\zeta(v_{i_1, j_1+1}) > \zeta(v_{i_0, j_0})$, so $\zeta(v_{i_1, j_1+1}) \geq \zeta(v_{i_1, j_1}) + 2$, violating maximality of $\zeta(v_{i_0, j_0})$. We conclude that $j_1 = \alpha_{i_1}$.

If $\alpha_{i_1} \geq j_0$ then we can define a new $z \in \mathcal{N}$ by

$$z v_{i,j} = \begin{cases} v_{i_1, \alpha_{i_1}} & i = i_0, j = j_0 \\ v_{i, j-1} & \text{otherwise.} \end{cases}$$

We have effectively moved the rightmost $\alpha_{i_0} - j_0 + 1$ blocks from row i_0 to row i_1 . Therefore, (without reordering rows) the right move $(i_1, i_0, \alpha_{i_0} - j_0 + 1)$ transforms z into

(α, ϵ) and we know that (α, β) is less than the colored Jordan type of z . On the other hand, ζ shows that z lies in the closure of $\mathcal{O}_{\lambda, \epsilon}$. So, the result follows by induction.

On the other hand, if $\alpha_{i_1} < j_0$ then there is a largest integer k satisfying $0 \leq k < \alpha_{i_1}$ such that $\zeta(v_{i_1, \lambda_{i_1} - t}) > \zeta(v_{i_0, j_0 - 1 - t})$ for each $0 \leq t \leq k$. Note that $t = 0$ always satisfies this inequality. We redefine ζ by setting

$$\begin{aligned}\zeta'(v_{i_1, \alpha_{i_1} - t}) &= \zeta(v_{i_0, j_0 - 1 - t}), \\ \zeta'(v_{i_0, j_0 - 1 - t}) &= \zeta(v_{i_1, \alpha_{i_1} - t}), \\ \zeta'(v_{i, j}) &= \zeta(v_{i, j}) \text{ otherwise.}\end{aligned}$$

In other words, we have simply swapped the values of ζ to correct the gap. We just need to verify that ζ' satisfies the appropriate properties, which is a simple exercise. The key point is that we have reduced the number of pairs (i, j) satisfying $\zeta(v_{i, j}) \geq \zeta(v_{i, j-1}) + 2$, so we must eventually find ourselves in the first case. \square

So far, we have suggested some properties of covers, but not carefully classified them. We won't prove this here, but the following is a description of the right moves that are covering relations:

For fixed (λ, ϵ) we say that $i \prec j$ if and only if $i < j$ and $\lambda_i > \lambda_j + \langle \epsilon_j - \epsilon_i \rangle$. Pictorially, this means that we can align the two rows in such a way that each column consists of a single color and row i overlaps row j at *each end*. This defines a partial order on \mathbb{N} . If (i, j, t) is a right move then it is a cover if and only if $t \leq n$ or $\lambda_i - \lambda_j - t \leq n$ and j is minimal with respect to the property $i \prec j$.

6.4 An alternative criterion

In order to fully describe the closure order, it will be helpful to begin with a simple parametrization of the x -stable colored subspaces of V .

Lemma 6.4.1. *Let $x \in \mathcal{N}$ with colored Jordan basis \mathcal{B} . Let $W \subset V$ be a colored x -stable subspace. Then there is a subset $\mathcal{A} \subset \mathcal{B}$ and an element $k \in K$ such that $k\mathcal{A}$ is a (colored) Jordan basis for $x|_W$ and $kx|_{\mathcal{A}} = xk|_{\mathcal{A}}$ (so $kxk^{-1}|_W = x|_W$). In other words, $k\mathcal{B}$ is a colored Jordan basis for kxk^{-1} that restricts to a colored Jordan basis for $kxk^{-1}|_W = x|_W$.*

Proof. Enumerate $\mathcal{B} = \{v_{i, j}\}$. Since W is x -stable there is a colored Jordan basis $\mathcal{B}_W = \{w_{i, j}\}$ for $x|_W$. Extend \mathcal{B}_W to a colored basis \mathcal{B}' of V .

It is clear that for fixed j we have $\xi(\{v_{i,j} \mid \lambda_i \geq j\}) = \xi(\ker x^j / \ker x^{j-1})$ and $\xi(\{w_{i,j} \mid \lambda_i \geq j\}) = \xi(\ker x^j|_W / \ker x^{j-1}|_W)$. It is also clear that the latter quantity cannot be larger than the former. Therefore, if we choose $w_{i,j}$ such that j is maximal then we can define $k^{-1}w_{i,j-1} = v_{i',j-1}$, where i' is any index such that $\chi(v_{i',j}) = \chi(w_{i,j})$. Proceed inductively. Once $k^{-1}|_W$ is defined, we may simply match up the remaining basis elements by any color-preserving bijection and extend linearly. \square

Assume that (λ, ϵ) is the colored partition corresponding to x . Since $\mathcal{A} \subset \mathcal{B}$, we can define a (nonnegative) marking of (λ, ϵ) by $i \mapsto \max\{j \geq 0 \mid v_{i,j} \in \mathcal{A} \cup \{0\}\}$. Since $k\mathcal{A}$ is a colored Jordan basis for $x|_W$, we conclude that if $v_{i,j} \in \mathcal{A}$ with $j > 1$ then $v_{i,j-1} \in \mathcal{A}$, as well. Therefore, we may view W as the span of the basis vectors to the left of the marks on (λ, ϵ) .

Note, however, that while the Jordan type of $x|_W$ is determined by the left side of the diagram there is no claim here regarding the Jordan type of $x|_{V/W}$. Furthermore, this is no bijection. While it should be clear that the left side of the marked diagram always determines an x -stable subspace, any two diagrams with the same left diagram determine the same K -conjugacy class of x -stable subspaces. This result does, however, enable us to view the set of x -stable colored subspaces of V as finite in some sense.

Now, for fixed $x \in \mathcal{N}$ and colored subspace $U \subset V$ we can construct the $\mathbb{F}[x]$ -submodule $\mathbb{F}[x](U) \subset V$.

Definition 6.4.2. If $x \in \mathcal{N}$ and f is a signature then we define $R_f(x) = \xi(\mathbb{F}[x](U))$, where $\dim(\mathbb{F}[x](U))$ is maximal among all $U \subset V$ satisfying $\xi(U) \leq f$. If $m \in \mathbb{Z}/n\mathbb{Z}$ and k is an integer then $R_{m,k}(x) = R_f(x)$, where f is the signature defined by $f(m) = k$ and $f(m') = 0$ for $m' \neq m$.

We still must show that $R_f(x)$ is well-defined, but it should otherwise be clear that it is constant on orbits. This is because if $y = k \cdot x$ (of type (λ, ϵ)) and $\dim(\mathbb{F}[x](U))$ is maximal for x then $\dim(k \cdot \mathbb{F}[x](U)) = \dim(\mathbb{F}[k \cdot x](k \cdot U)) = \dim(\mathbb{F}[y](k \cdot U))$ is maximal for y and $\xi(U) = \xi(k \cdot U)$. Therefore, we have the following, which justifies the notation $R_f(\lambda, \epsilon) = R_f(x)$:

Lemma 6.4.3. *If $y \in \mathcal{O}_x$ then $R_f(y) = R_f(x)$ for each signature f .*

Now, there are infinitely many signatures f , so if we are to learn anything from R_f then we must figure out a way to reduce the computation of R_f to a finite problem.

Fortunately, this is completely straightforward. The following lemma shows that we need only compute R_f for $f \leq \xi(V)$:

Lemma 6.4.4. *If f is a signature then $R_f(x) = R_g(x)$, where $g(m) = \min(f(m), \xi_m(x))$. In particular, $g \leq \xi(V)$.*

Proof. Each colored subspace U of V satisfies $\xi(U) \leq \xi(V)$. □

Lemma 6.4.5. *Let W be colored and x -stable, with marked colored partition (λ, ϵ, μ) and corresponding colored Jordan basis $\{v_{i,j}\}$. That is, W is the span of $\{v_{i,j} \mid j \leq \mu_i\}$. Let U be the span of $\{v_{i,\mu_i}\}$. Then $W = \mathbb{F}[x](U)$. Moreover, if U' is another subspace with $W = \mathbb{F}[x](U')$ then $\xi(U') \geq \xi(U)$. In particular, any x -stable subspace of V can be generated by a subspace whose signature f satisfies $|f| \leq l(\lambda)$.*

Proof. The fact that $W = \mathbb{F}[x](U)$ is clear. The rest follows from the classification of colored Jordan bases. □

Proposition 6.4.6. *$R_f(x)$ is well-defined. That is, if $\xi(U) \leq f$ and $\xi(W) \leq f$ and $\dim \mathbb{F}[x](U) = \dim \mathbb{F}[x](W)$ is maximal then $\xi(\mathbb{F}[x](U)) = \xi(\mathbb{F}[x](W))$. Moreover, if $\xi(W) \leq f$ then $\xi(\mathbb{F}[x](W)) \leq R_f(x)$.*

Proof. Let $U \subset V$ be any colored subspace satisfying $\xi(U) \leq f$ and let $\mathcal{B} = \{v_{i,j}\}$ be a colored Jordan basis for x of type (λ, ϵ) . By K -conjugacy, we may assume that $\mathbb{F}[x](U) = \langle \mathcal{B}^\mu \rangle$ for some marking μ of λ . Let $j_0 = \max\{j \mid f(\chi(v_{i,j})) > 0 \text{ for some } i\}$ and let i_0 satisfy $f(\chi(v_{i_0,j_0})) > 0$. Maximality of j_0 forces $f(\chi(v_{i_0,j})) = 0$ whenever $j_0 < j \leq \lambda_{i_0}$, so $\mu_{i_0} \leq j_0$. Set $m_0 = \chi(v_{i_0,j_0})$. If $\mu_{i_0} < j_0$ then the argument is divided into several cases.

1. If $f(m_0) > \xi_{m_0}(\{v_{i,\mu_i} \mid i \in \mathbb{N}\})$ then we may set

$$\mu'_i = \begin{cases} j_0 & i = i_0, \\ \mu_i & i \neq i_0. \end{cases}$$

It is clear that $\xi(\{v_{i,\mu'_i} \mid i \in \mathbb{Z}\}) \leq f$ and that $\xi(\mathcal{B}^\mu) < \xi(\mathcal{B}^{\mu'})$.

2. If $\chi(v_{i_0,\mu_{j_0}}) = m_0$ then we can define

$$\mu'_i = \begin{cases} j_0 & i = i_0, \\ \mu_i & i \neq i_0. \end{cases}$$

Again, it is clear that $\xi(\{v_{i,\mu'_i} \mid i \in \mathbb{Z}\}) \leq f$ and that $\xi(\mathcal{B}^\mu) < \xi(\mathcal{B}^{\mu'})$.

3. If $f(m_0) = \xi_{m_0}(\{v_{i,\mu_i} \mid i \in \mathbb{N}\})$ then there is an integer $i_1 \neq i_0$ such that $\chi(v_{i_1,\mu_{i_1}}) = m_0$. We define

$$\mu'_i = \begin{cases} j_0 & i = i_0, \\ \mu_{i_1} - \langle j_0 - \mu_{i_0} \rangle & i = i_1 \\ \mu_i & i \neq i_0. \end{cases}$$

Once again, it should be clear that $\xi(\{v_{i,\mu'_i} \mid i \in \mathbb{Z}\}) \leq f$. This time, though, the best we can do is $\xi(\mathcal{B}^\mu) \leq \xi(\mathcal{B}^{\mu'})$. The inequality is strict if and only if $j_0 - \mu_{i_0} < n$.

This argument shows that we can always modify μ , if necessary, to assume that $\mu_{i_0} = j_0$. This modification either preserves the signature of $\mathbb{F}[x](U)$ or increases it. The result follows by induction after taking the quotient $V/\langle v_{i_0,1}, \dots, v_{i_0,\lambda_{i_0}} \rangle$ and computing $R_g(\bar{x})$, where $g(m_0) = f(m_0) - 1$ and $g(m) = f(m)$ if $m \neq m_0$. The induction ends when it has been reduced to a signature f satisfying $f(m) \cdot \xi_m(V) = 0$ for each m . In this case, $U = 0$, so $R_f(x)(m) = 0$ for each m . \square

Note that the proof of proposition 6.4.6 gives an effective algorithm for computing $R_f(x)$. We will make it more explicit:

Algorithm 6.4.7.

1. Let (λ, ϵ) be a colored partition and f a signature.
2. Let (α, β) be the zero colored partition.
3. Draw the left-justified colored diagram for (λ, ϵ) .
4. If $f(m) = 0$ for each color m that appears in the diagram then goto step 8.
5. Locate any rightmost box (i, j) (that is, j is maximal) in the diagram for (λ, ϵ) whose color m satisfies $f(m) > 0$.
6. Augment (α, β) by copying the leftmost j boxes from row i to (α, β) and delete row i from (λ, ϵ) .
7. Return to step 4.
8. $R_f(\lambda, \epsilon) = \xi(\alpha, \beta)$.

In the particular case where there is a unique color m_0 such that $f(m_0) = k > 0$ the algorithm reduces. We define $\lambda'_i = \lambda_i - \langle m_0 - \epsilon_i \rangle$ and $\epsilon'_i = m_0$. This has trimmed the right end of each row so that the rightmost color of each row is m_0 . Then $R_f(\lambda, \epsilon) = R_{m_0, k}(\lambda, \epsilon)$ is the signature of the k longest rows of (λ', ϵ') .

Lemma 6.4.8. *Let f and g be signatures and let $x \in \mathcal{N}$. Then*

1. $R_{f+g}(x) \leq R_f(x) + R_g(x)$.
2. If $f \leq g$ then $R_f(x) \leq R_g(x)$.

Proof.

1. If $\xi(U_1) \leq f$ and $\xi(U_2) \leq g$ then $\xi(U_1 + U_2) \leq f + g$.
2. If $\xi(U) \leq f$ then $\xi(U) \leq g$. □

Lemma 6.4.9. *If $x \in \mathcal{N}$ and f is a signature then $R_f(x) \geq f$ if and only if $f \leq \xi(V)$.*

Proof. If $f \leq \xi(V)$ then there is a subspace $U \subset V$ of signature f and $U \subset \mathbb{F}[x](U)$, so $R_f(x) \geq \xi(\mathbb{F}[x](U)) \geq \xi(U) = f$. Clearly, if $f \leq R_f(x)$ then we just observe that $R_f(x)$ is the signature of some subspace of V , so $f \leq R_f(x) \leq \xi(V)$. □

We observe here that the collection of signatures $R_f(x)$ form a complete invariant of \mathcal{O}_x . In essence, this follows from the proof of proposition 6.4.6. By choosing a signature f_0 with $|f_0| = 1$ so that $|R_{f_0}(x)|$ is maximal, we observe that a longest row of the colored partition has length $|R_{f_0}(x)|$ and rightmost color m_0 , where $f_0(m_0) = 1$. The second row can be determined by choosing f_1 so that $f_0 < f_1$, $|f_1| = 2$ and $|R_{f_0}(x)|$ is maximal. The rest of the rows can be determined in a similar way.

At this point we choose a colored basis \mathcal{B} of V , ordered in some way. Throughout the rest of this section we view elements of \mathcal{N} and V as matrices and coordinate vectors, respectively, relative to this ordered basis. For a fixed signature $f \leq \xi(V)$, choose a colored subspace $U \subset V$ such that $\xi(U) = f$ and $\xi(\mathbb{F}[x](U)) = R_f(x)$. Set $k = |f|$. Choose a colored basis w_1, \dots, w_k of U .

Now, let $y \in \mathcal{O}_x$ and set $W = \mathbb{F}[y](U)$. Since y is nilpotent with nilpotency at most $N = \dim V$, it is clear that W is spanned by the kN vectors $y^i w_j, 0 \leq i < N, 1 \leq j \leq k$. If we write these vectors with coordinates relative to \mathcal{B} then we may form a matrix A of size $N \times kN$ with these coordinate vectors as columns. Since \mathcal{B} and $y^i w_j$ are colored,

all nonzero entries on the coordinate vector of $y^i w_j$ lie in the positions that correspond precisely to the elements of \mathcal{B} of a fixed color $m_0 = \chi(w_j) + [i]$. Therefore, for each $m \in \mathbb{Z}/n\mathbb{Z}$ we can form the submatrix A_m of A that includes all columns, but only those rows that correspond to elements of \mathcal{B} of color m .

From linear algebra we know that $\text{rank } A = \dim W$. Similarly,

$$\begin{aligned} \text{rank } A_m &= \dim W \cap V_m \\ &= \xi_m(W) \leq R_f(y)(m) \\ &= R_f(x)(m). \end{aligned}$$

Therefore, if $R_f(x)(m) < \dim V_m$ and $r = \text{rank } A_m$ then all $(r+1) \times (r+1)$ minors of A_m vanish. These are polynomials in the entries of A_m , which are themselves polynomials in the entries of w_i and y . We can view these minors as polynomials in the entries of y , whose coefficients are (polynomial) functions of the entries of w_i . That is, w_1, \dots, w_k determine a collection of polynomial equations (via the $(r+1) \times (r+1)$ minors) satisfied by y for each $y \in \mathcal{O}_x$. Therefore, the collection of all such polynomials determined by all $U \subset V$ of signature f determine a Zariski closed set containing \mathcal{O}_x , hence $\overline{\mathcal{O}_x}$.

Now, if $x' \in \overline{\mathcal{O}_x}$ then we can produce the corresponding matrix A'_m . We observe that all $(r+1) \times (r+1)$ minors of A' vanish by the closure condition, so $\text{rank } A'_m \leq R_f(x)(m)$. Since this inequality must hold regardless of the choice of U or of m we conclude that $R_f(x') \leq R_f(x)$. We summarize:

Proposition 6.4.10. *If $\mathcal{O}_y \subset \overline{\mathcal{O}_x}$ then $R_f(y) \leq R_f(x)$ for each signature f .*

We wish to show that the converse of this proposition is also true, but this requires some work. Our goal will be to show that if $R_f(y) \leq R_f(x)$ for each signature f then $s_k(y) \geq s_k(x)$ for each k . In fact, we will prove a result that appears, at first glance, to be stronger. The following lemma takes care of most of the work for us.

Lemma 6.4.11. *Let (λ, ϵ) and (α, β) be n -colored partitions, though possibly of different signatures. For each $k \in \mathbb{N}$ let (λ^k, ϵ^k) and (α^k, β^k) denote the colored partitions constructed from (λ, ϵ) and (α, β) by deleting the leftmost k columns from the left-justified diagrams. If m be a color that satisfies $R_{m,i}(\lambda, \epsilon) \geq R_{m,i}(\alpha, \beta)$ for each $i \in \mathbb{N}$ then $R_{m,i}(\lambda^k, \epsilon^k) \geq R_{m,i}(\alpha^k, \beta^k)$ for each k .*

Proof. As all cases are proved in identical fashion, we will prove the case $m = 0$, freeing up the variable m to represent an arbitrary color. Fix an integer $r > 0$. The signatures $R_{0,i}(\lambda, \epsilon)$, $1 \leq i \leq r$ determine the rows of a sub-diagram $(\tilde{\lambda}^r, 0)$ of (λ, ϵ) . That is, $|R_{0,i}(\lambda, \epsilon) - R_{0,i-1}(\lambda, \epsilon)|$ is the length of row i and the rightmost position has color 0. Clearly, $\xi(\tilde{\lambda}^r, 0) = R_{0,r}(\lambda, \epsilon)$.

Since the rightmost box in each row of $(\tilde{\lambda}^r, 0)$ has color 0, each box of color $m \neq 0$ must lie immediately to the left of a box of color $m - [1]$. This gives an injective map $\{\text{boxes of color } m\} \rightarrow \{\text{boxes of color } m - [1]\}$. On the other hand, each box of color $m - [1]$ must have a box of color m immediately to the left, unless it is the leftmost box in its row. In other words, the boxes of color $m - [1]$ that are *not* in the first column are in bijection with the boxes of color m . Obviously, the same holds for (α, β) , so we conclude that

$$\begin{aligned} R_{0,r}(\lambda^1, \epsilon^1)(m - [1]) &= R_{0,r}(\lambda, \epsilon)(m) \\ &\geq R_{0,r}(\alpha, \beta)(m) \\ &= R_{0,r}(\alpha^1, \beta^1)(m - [1]). \end{aligned}$$

It only remains to show that $R_{0,r}(\lambda^1, \epsilon^1)([-1]) \geq R_{0,r}(\alpha^1, \beta^1)([-1])$. Observe that the total number of boxes in the first column is $l(\tilde{\lambda})$ and we have accounted for each box whose color is not equal to $[-1]$. So, the number of boxes in the first column of color $[-1]$ is equal to

$$l(\tilde{\lambda}) - \sum_{m=1}^{n-1} (R_{0,r}(\lambda, \epsilon)(m - [1]) - R_{0,r}(\lambda, \epsilon)(m)) = l(\tilde{\lambda}) - R_{0,r}(\lambda, \epsilon)(0) + R_{0,r}(\lambda, \epsilon)([-1])$$

and we have

$$\begin{aligned} R_{0,r}(\lambda^1, \epsilon^1)([-1]) &= R_{0,r}(\lambda, \epsilon)([-1]) - (l(\tilde{\lambda}) - R_{0,r}(\lambda, \epsilon)(0) + R_{0,r}(\lambda, \epsilon)(n - 1)) \\ &= R_{0,r}(\lambda, \epsilon)(0) - l(\tilde{\lambda}). \end{aligned}$$

If $l(\tilde{\lambda}) \leq l(\tilde{\alpha})$, this equation makes it clear that $R_{0,r}(\lambda, \epsilon)([-1]) \geq R_{0,r}(\alpha, \beta)([-1])$. On the other hand, if $l(\tilde{\lambda}) > l(\tilde{\alpha})$ then we must be a little more careful in our strategy. There is a smallest integer t such that $R_{0,t}(\lambda, \epsilon) = R_{0,t+1}(\lambda, \epsilon)$. Similarly, there is a smallest integer t' such that $R_{0,t'}(\alpha, \beta) = R_{0,t'+1}(\alpha, \beta)$. If $r \leq t$ then $l(\tilde{\lambda}) = r$; otherwise, $l(\tilde{\lambda}) = t$. A similar result holds for (α, β) . Since $l(\tilde{\lambda}) > l(\tilde{\alpha})$, we conclude that $r > t'$. If $r > t$ then there is nothing to check as all the formulas will be the same as for $r = t$. So,

we find ourselves in the case $t \geq r > t'$. Since each row must have a box of color 0, it is clear that if $r \leq t$ then $R_{0,r}(\lambda, \epsilon)(0) - R_{0,r-1}(\lambda, \epsilon)(0) \geq 1$. Therefore,

$$\begin{aligned}
R_{0,r}(\lambda^1, \epsilon^1)([-1]) &= R_{0,r}(\lambda, \epsilon)(0) - r \\
&= R_{0,t'}(\lambda, \epsilon)(0) - t' + \sum_{j=t'+1}^r (R_{0,j}(\lambda, \epsilon)(0) - R_{0,j-1}(\lambda, \epsilon)(0) - 1) \\
&\geq R_{0,t'}(\lambda, \epsilon)(0) - t' \\
&\geq R_{0,t'}(\alpha, \beta)(0) - t' \\
&= R_{0,r}(\alpha^1, \beta^1)([-1]).
\end{aligned}$$

It should be clear that the general case follows inductively from the case $k = 1$. \square

Lemma 6.4.12. *Fix a color m and colored partitions (λ, ϵ) and (α, β) . If*

$$R_{m,i}(\alpha, \beta) \leq R_{m,i}(\lambda, \epsilon)$$

for each $i \in \mathbb{N}$ then $s_k(\alpha, \beta)(m) \geq s_k(\lambda, \epsilon)(m)$ for each k .

Proof. We first recall that $s_k(\lambda, \epsilon)(m)$ is the number of boxes of color m in the first k columns of the diagram. The number of boxes of color m that remain is, therefore, equal to $R_{0,l(\lambda)}(\lambda^k, \epsilon^k)(m)$. We conclude that $s_k(\lambda, \epsilon)(m) + R_{0,l(\lambda)}(\lambda^k, \epsilon^k)(m) = \dim V_m$, which gives us

$$\begin{aligned}
s_k(\lambda, \epsilon) &= \dim V_m - R_{0,l(\lambda)}(\lambda^k, \epsilon^k)(m) \\
&\leq \dim V_m - R_{0,l(\lambda)}(\alpha^k, \beta^k)(m) \\
&= s_k(\alpha, \beta),
\end{aligned}$$

yielding the desired result. \square

Theorem 6.4.13. *If (λ, ϵ) and (α, β) are colored partitions then the following conditions are equivalent:*

1. $(\alpha, \beta) \leq (\lambda, \epsilon)$,
2. $R_f(\alpha, \beta) \leq R_f(\lambda, \epsilon)$ for every signature f ,
3. $R_{m,k}(\alpha, \beta) \leq R_{m,k}(\lambda, \epsilon)$ for each $(m, k) \in \mathbb{Z}/n\mathbb{Z} \times \mathbb{Z}^{\geq 0}$.

Proof. This is just a summary of previous results. \square

For computational purposes, condition 1 is the easiest to check. If we wish to compare (λ, ϵ) and (α, β) with the s_k criterion, we need only compute s_k for $k = 1, \dots, \min(\lambda_1, \alpha_1)$. However, it is worth noting that condition 4 is a *vast* improvement over condition 3. There are infinitely many signatures f that we could check, but lemma 6.4.4 suggests that we need only check these inequalities for signatures $f \leq \xi(V)$. The number of these is equal to $\prod_{m \in \mathbb{Z}/n\mathbb{Z}} (\xi_m(V) + 1)$.

On the other hand, if we are to use condition 4 then we just need to enumerate the pairs (m, k) . It is obvious that $R_{m,0} = 0$ for each m and that $k \leq \dim V_m$. Therefore, the number of signatures we need to compare is $\sum_m \dim V_m = \dim V$. As an example, suppose that $\dim V = n$ and $\dim V_m = 1$ for each m . Then the product formula reduces to 2^n and the second formula yields n , which is much smaller.

CHAPTER 7

ENHANCED NILPOTENT ORBIT CLOSURES

In the enhanced colored nilpotent case, just as in the colored nilpotent case, K acts on $\tilde{V} \times \mathcal{N}$ with finitely many orbits. Therefore, the orbits are partially ordered by the rule $\mathcal{O}' \leq \mathcal{O}$ if and only if $\mathcal{O}' \subset \overline{\mathcal{O}}$. We construct a resolution of singularities for the closure of each enhanced nilpotent orbit. From this construction we derive an alternative geometric description of the closure order, as well as several combinatorial properties of the closure order.

7.1 Resolution of singularities

We first point out that if $m \in \mathbb{Z}/n\mathbb{Z}$ then $V_m \times \mathcal{N} \subset \tilde{V} \times \mathcal{N}$ is a Zariski-closed subset. Since each orbit $\mathcal{O} \in K \backslash (\tilde{V} \times \mathcal{N})$ is contained in $V_m \times \mathcal{N}$ for some m , we conclude that $\overline{\mathcal{O}}$ is also contained in $V_m \times \mathcal{N}$. Therefore, to understand the closure order we can fix a color m and just consider the closure order in the set $K \backslash (V_m \times \mathcal{N})$. Since the constructions and results are identical for each m , we will simply assume that $m = 0$ throughout the remainder of this exposition. In keeping with this assumption, from now on we will assume that each striped n -bipartition (λ, ϵ, μ) satisfies $\epsilon + [\lambda - \mu] = 0$. We define the following variety:

Definition 7.1.1. If (λ, ϵ, μ) is a marked colored partition then we define

$$\tilde{\mathcal{F}}_{\lambda, \epsilon, \mu} = \left\{ (w, y, (W_k)) \in V_0 \times \mathcal{N} \times \mathcal{F}_{\lambda, \epsilon, \mu} \mid (y, (W_k)) \in \hat{\mathcal{F}}_{\lambda, \epsilon, \mu}, w \in W_{\mu_1} \right\}.$$

Theorem 7.1.2. *If (λ, ϵ, μ) is a marked colored partition then the natural projection $\pi : \tilde{\mathcal{F}}_{\lambda, \epsilon, \mu} \rightarrow V_0 \times \mathcal{N}$ is a resolution of singularities for $\overline{\mathcal{O}}_{\lambda, \epsilon, \mu}$.*

Proof. It is clear that if $(v, x) \in V_0 \times \mathcal{N}$ then $(v, x, (W_k^{v,x})) \in \tilde{\mathcal{F}}_{\lambda, \epsilon, \mu}$. This shows that the image of π includes $\mathcal{O}_{\lambda, \epsilon, \mu}$. There is also a projection $\tilde{\mathcal{F}}_{\lambda, \epsilon, \mu} \rightarrow \hat{\mathcal{F}}_{\lambda, \epsilon, \mu}$ that is a vector bundle over a smooth irreducible variety, ensuring that $\tilde{\mathcal{F}}_{\lambda, \epsilon, \mu}$ is nonsingular and irreducible.

Since $\mathcal{F}_{\lambda,\epsilon,\mu}$ is a projective variety, we know that π is proper, hence the image of π is a K -stable irreducible closed subvariety of $V_0 \times \mathcal{N}$. We conclude that its image is the closure of a single K -orbit \mathcal{O} . The rank of $\tilde{\mathcal{F}}_{\lambda,\epsilon,\mu}$ as a vector bundle over $\widehat{\mathcal{F}}_{\lambda,\epsilon,\mu}$ is equal to $\dim(V_0 \cap W_{\mu_1}) = \dim(V_0 \cap E^x v)$, where $(v, x) \in \mathcal{O}_{\lambda,\epsilon,\mu}$. Therefore,

$$\begin{aligned} \dim \mathcal{O} &\leq \dim \tilde{\mathcal{F}}_{\lambda,\epsilon,\mu} \\ &= \dim V_0 \cap E^x v + \dim \widehat{\mathcal{F}}_{\lambda,\epsilon,\mu} \\ &= \dim V_0 \cap E^x v + \dim \mathcal{O}_{\lambda,\epsilon} \\ &= \dim \mathcal{O}_{\lambda,\epsilon,\mu}. \end{aligned}$$

But $\mathcal{O}_{\lambda,\epsilon,\mu} \subset \overline{\mathcal{O}}$ implies that $\dim \mathcal{O}_{\lambda,\epsilon,\mu} \leq \dim \mathcal{O}$, so $\dim \mathcal{O} = \dim \mathcal{O}_{\lambda,\epsilon,\mu}$. Since the orbit in $\overline{\mathcal{O}}$ of top dimension is unique, we conclude that $\mathcal{O} = \mathcal{O}_{\lambda,\epsilon,\mu}$. Finally, from [1] we know that if $(v, x, (W_k)) \in \tilde{\mathcal{F}}_{\lambda,\epsilon,\mu}$ then $W_k = W_k^{v,x}$, completing the proof. \square

Proposition 7.1.3. *Let (λ, ϵ, μ) be a striped n -bipartition with corresponding minimal bipartition $(\lambda, \epsilon, \tilde{\mu})$. Then $(v, x) \in V_0 \times \mathcal{N}$ is contained in $\overline{\mathcal{O}}_{\lambda,\epsilon,\mu}$ if and only if there is an x -stable subspace $W \subset V$ such that*

1. $\xi(W) = \xi(\tilde{\mu}, \epsilon + [\lambda - \tilde{\mu}])$,
2. $v \in W$,
3. The colored Jordan type (α, β) of $x|_W$ satisfies $\mathcal{O}_{\alpha,\beta} \leq \mathcal{O}_{\tilde{\mu}, \epsilon + [\lambda - \tilde{\mu}]}$.
4. The colored Jordan type (α', β') of $x|_{V/W}$ satisfies $\mathcal{O}_{\alpha',\beta'} \leq \mathcal{O}_{\lambda - \tilde{\mu}, \epsilon}$.

Proof. By theorem 7.1.2, $(v, x) \in \mathcal{O}_{\lambda,\epsilon,\mu}$ if and only if there is a partial flag (W_k) such that $v \in W_{\mu_1}$ and $(x, (W_k)) \in \widehat{\mathcal{F}}_{\lambda,\epsilon,\mu}$. If we set $W = W_{\mu_1}$ then this is equivalent to a pair of colored partial flags

$$0 = W_0 \subset W_1 \subset \cdots \subset W_{\mu_1},$$

$$0 = W_{\mu_1}/W_{\mu_1} \subset \cdots \subset W_{\lambda_1}/W_{\mu_1} = V/W_{\mu_1}$$

such that $v \in W_{\mu_1}$, $xW_i \subset W_{i-1}$ if $i \leq \mu_1$, and $x(W_j/W_{\mu_1}) \subset W_{j-1}/W_{\mu_1}$ if $j \geq \mu_1$.

Let $(w, y) \in \mathcal{O}_{\lambda,\epsilon,\mu}$ satisfy $W_k = W_k^{w,y}$ for each k and let $\mathcal{B} = \{v_{i,j}\}$ be a normal basis for (w, y) . Finally, if we set $u = \sum v_{i,\mu_i}$ then the existence of the above chains is equivalent to $(x|_W, (W_k)_{k=1}^{\mu_1}) \in \widehat{\mathcal{F}}_{u,y|E^x u}$ and $(x|_{V/W}, (W_k/W)_{k=\mu_1}^{\lambda_1}) \in \widehat{\mathcal{F}}_{0,y|V/E^x u}$, as defined in the remark following corollary 6.1.4. The result follows from theorem 6.1.3. \square

7.2 More geometry

Our goal here is to develop effective combinatorial criteria for determining if two striped n -bipartitions (α, β, γ) and (λ, ϵ, μ) satisfy $\mathcal{O}_{\alpha, \beta, \gamma} \leq \mathcal{O}_{\lambda, \epsilon, \mu}$. This will be accomplished by studying various important geometric constructions, some modeled after section 6.4.

Lemma 7.2.1. *If (α, β, γ) and (λ, ϵ, μ) are striped n -bipartition and $\mathcal{O}_{\alpha, \beta, \gamma} \leq \mathcal{O}_{\lambda, \epsilon, \mu}$ then $(\alpha, \beta) \leq (\lambda, \epsilon)$.*

Proof. $\overline{\mathcal{O}}_{\lambda, \epsilon}$ is the image of the algebraic morphism $\theta : \overline{\mathcal{O}}_{\lambda, \epsilon, \mu} \rightarrow \mathcal{N}$ defined in section 4.3. □

Definition 7.2.2. If $(v, x) \in V_0 \times \mathcal{N}$ and f is a signature then we define $R_f(v, x)$ to be the signature of any submodule $\mathbb{F}[x](v, U)$ of maximal dimension, where $\xi(U) \leq f$. If $m \in \mathbb{Z}/n\mathbb{Z}$ and $k \in \mathbb{Z}^{\geq 0}$ then we define $R_{m, k}(v, x) = R_f(v, x)$, where $f(m) = k$ and $f(m') = 0$ if $m' \neq m$. Since $R_{m, 0}(v, x) = \xi(\mathbb{F}[x](v))$ for each $m \in \mathbb{Z}/n\mathbb{Z}$, we simplify notation, declaring that $R_0(v, x) = \xi(\mathbb{F}[x](v))$.

Lemma 7.2.3. *If $x \in \mathcal{N}$ and f is a signature then $R_f(0, x) = R_f(x)$.*

Lemma 7.2.4. *Let $(v, x) \in V_0 \times \mathcal{N}$ and set $W = \mathbb{F}[x](v)$ and $\bar{x} = x|_{V/W}$. Then*

$$R_f(v, x) = \xi(W) + R_f(\bar{x})$$

for each signature f . In particular, $R_f(v, x)$ is well-defined.

Proof. This follows immediately from the fact that any $\mathbb{F}[x]$ -submodule of the form $\mathbb{F}[x](v, U)$ must contain W and these are in bijection with $\mathbb{F}[\bar{x}]$ -submodules of V/W . □

Note that the assignment $(v, x) \mapsto R_f(v, x)$ is clearly constant on orbits, since elements that share an orbit are related by a colored change of basis. Therefore, we may define $R_f(\mathcal{O}_{v, x}) = R_f(v, x)$. Naturally, if (λ, ϵ, μ) is the type of (v, x) then we write $R_f(\lambda, \epsilon, \mu) = R_f(v, x)$, as well.

As in section 6.4, let \mathcal{B} be any ordered colored basis of V . Fix any $U \subset V$ of signature $f \leq \xi(V)$ and choose a colored basis $w_1, \dots, w_{|f|}$ of U . Fix an orbit \mathcal{O} and a representative $(v, x) \in \mathcal{O}$. Set $W = \mathbb{F}[x](v, U)$ and $w_0 = v$. Since x is nilpotent with nilpotency at most $N = \dim V$, it is clear that $W = \mathbb{F}[x](v, U)$ is spanned by the $(k+1)N$ vectors $x^i w_j, 0 \leq i < N, 0 \leq j \leq |f|$. If we write these vectors with coordinates relative

to \mathcal{B} then we may form a matrix A of size $N \times (k+1)N$ with these coordinate vectors as columns. If $m \in \mathbb{Z}/n\mathbb{Z}$ we let A_m be the submatrix of A whose columns correspond to the elements of \mathcal{B} of color m .

From linear algebra we know that $\text{rank } A_m = \dim(W \cap V_m) \leq R_f(v, x)(m)$. Therefore, all $(R_f(v, x)(m) + 1) \times (R_f(v, x)(m) + 1)$ minors of A vanish. These are polynomials in the entries of A , which are themselves polynomials in the entries of v , w_i and x . We can view these minors as polynomials in the entries of x and v , whose coefficients are (polynomial) functions of the entries of w_i . That is, w_1, \dots, w_k determine a collection of polynomial equations (via the $(R_f(v, x)(m) + 1) \times (R_f(v, x)(m) + 1)$ minors) satisfied by (v, x) for each $(v, x) \in \mathcal{O}$. Therefore, the collection of all such polynomials determined by all $U \subset V$ of signature f determine a Zariski closed set containing \mathcal{O} , hence $\overline{\mathcal{O}}$.

Now, if $(w, y) \in \overline{\mathcal{O}}_{v,x}$ we can select U of signature f as above and produce the corresponding matrix A' . We observe that all $(R_f(v, x)(m) + 1) \times (R_f(v, x)(m) + 1)$ minors of A'_m vanish by the closure condition, so $\text{rank } A'_m \leq R_f(v, x)(m)$. Since this inequality must hold regardless of the choice of U we conclude that $R_f(w, y)(m) \leq R_f(v, x)(m)$. We summarize:

Proposition 7.2.5. *If $\mathcal{O}_{w,y} \leq \mathcal{O}_{v,x}$ then $R_f(w, y) \leq R_f(v, x)$ for each signature f .*

Now we need a practical algorithm for computing $R_f(v, x)$. By lemma 7.2.4 it is enough to be able to compute $\xi(\mathbb{F}[x](v))$ and $R_f(x|_{V/\mathbb{F}[x](v)})$. The first can easily be computed using lemma 3.3.2 because $\xi(\mathbb{F}[x](v)) = \xi(\mathcal{B}_{v,x})$. The second can be computed once we have determined the colored Jordan type of \bar{x} . Fortunately, there is a simple algorithm for this.

Fix a striped n -bipartition (λ, ϵ, μ) containing a representative $(v, x) \in \mathcal{O}_{\lambda, \epsilon, \mu}$. Let $\mathcal{B} = \{v_{i,j}\}$ be a normal basis for (v, x) of type (λ, ϵ, μ) . The crucial observation here is that $\{\sum_i v_{i, \mu_i - k} \mid 0 \leq k < \max\{\mu_j \mid j \in \mathbb{N}\}\}$ is a basis for $\mathbb{F}[x](v)$. Therefore, if \bar{v} denotes the image of a vector v in the quotient $V/\mathbb{F}[x](v)$ then $\bar{v}_{i,j} = 0$ if and only if $j \leq \mu_i$ and $v_{i', \mu'_i - (\mu_i - j)} = 0$ for each $i' \neq i$. The latter condition is equivalent to $\mu'_i + j \leq \mu_i$. In other words, $\mu_i > \mu_{i'}$ for each $i' \neq i$. From here, we apply the algorithm suggested by the proof of proposition 3.3.3:

Algorithm 7.2.6.

1. Draw the mark-aligned diagram for the striped n -bipartition (λ, ϵ, μ) .

2. Let (α, β) be the zero colored partition.
3. If there is no row i with $\mu_i > 0$, move any remaining nonzero rows from (λ, ϵ, μ) to (α, β) , removing the marks. The new (α, β) is the colored Jordan type of \bar{x} , so we can stop.
4. Since there is a row i with μ_i nonzero, there must be a row i with μ_i maximal. If i is unique with this property, delete the leftmost box in row i and return to step 3. Otherwise, go to step 5.
5. We seek a longest Jordan block. Since no square in the diagram represents zero in the quotient, we select any longest row, disregarding the marks. Move this row (removing the mark) from (λ, ϵ, μ) to (α, β) and return to step 3.

7.3 The enhanced closure order

We begin by restating earlier results that motivate the remainder of this section.

Proposition 7.3.1. *If (α, β, γ) and (λ, ϵ, μ) are striped n -bipartitions and $\mathcal{O}_{\alpha, \beta, \gamma} \leq \mathcal{O}_{\lambda, \epsilon, \mu}$ then for each signature f we have*

1. $R_f(\alpha, \beta) \leq R_f(\lambda, \epsilon)$,
2. $R_f(\alpha, \beta, \gamma) \leq R_f(\lambda, \epsilon, \mu)$.

Proof. This is just lemma 7.2.1 together with proposition 7.2.5. □

Definition 7.3.2. If (λ, ϵ, μ) and (α, β, γ) are striped n -bipartitions then we say that $(\alpha, \beta, \gamma) \leq (\lambda, \epsilon, \mu)$ if $R_{m,k}(\alpha, \beta) \leq R_{m,k}(\lambda, \epsilon)$ and $R_{m,k}(\alpha, \beta, \gamma) \leq R_{m,k}(\lambda, \epsilon, \mu)$ for each $(m, k) \in \mathbb{Z}/n\mathbb{Z} \times \mathbb{Z}^{\geq 0}$.

Proposition 7.3.3. *The relation \leq given in definition 7.3.2 is a partial order on the set of striped n -bipartitions.*

Proof. Transitivity and reflexivity follow immediately from the definition. Antisymmetry follows from proposition 7.4.1. All we have to check is that if $(\lambda, \epsilon, \mu) \leq (\lambda, \epsilon, \delta)$ and $(\lambda, \epsilon, \delta) \leq (\lambda, \epsilon, \mu)$ then $\delta = \mu$. The inequalities force $R_0(\lambda, \epsilon, \delta) = R_0(\lambda, \epsilon, \mu)$, so by proposition 7.4.1 we have $\mathcal{O}_{\lambda, \epsilon, \mu} \leq \mathcal{O}_{\lambda, \epsilon, \delta}$ and $\mathcal{O}_{\lambda, \epsilon, \delta} \leq \mathcal{O}_{\lambda, \epsilon, \mu}$. But the closure order is a partial order, so $\mathcal{O}_{\lambda, \epsilon, \delta} = \mathcal{O}_{\lambda, \epsilon, \mu}$. We conclude that $\delta = \mu$. □

If we look at the combinatorial criteria presented in [1], we find that in the case $n = 1$ the converse of proposition 7.3.1 is true. That is, these inequalities are precisely the conditions that guarantee that a closure relation exists between two orbits. It is tantalizing to hope that this holds in general. That is, we would like to see that this combinatorial order and the closure order are the same:

Conjecture 7.3.4. *If (α, β, γ) and (λ, ϵ, μ) are striped n -bipartitions then $\mathcal{O}_{\alpha, \beta, \gamma} \leq \mathcal{O}_{\lambda, \epsilon, \mu}$ if and only if $(\alpha, \beta, \gamma) \leq (\lambda, \epsilon, \mu)$.*

Over the remaining sections, we will prove the conjecture in a few general cases. Even in the cases that remain, we will present evidence that the conjecture holds, though the evidence falls short of a complete proof of the conjecture.

7.4 First case

The goal of this section is to prove conjecture 7.3.4 in the case where the left diagrams of (λ, ϵ, μ) and (α, β, γ) have the same longest row.

Proposition 7.4.1. *If $(\alpha, \beta, \gamma) \leq (\lambda, \epsilon, \mu)$ and $R_0(\alpha, \beta, \gamma) = R_0(\lambda, \epsilon, \mu)$ then*

$$\mathcal{O}_{\alpha, \beta, \gamma} \leq \mathcal{O}_{\lambda, \epsilon, \mu}.$$

In order to prove this result, we present a variant of algorithm 7.2.6:

Algorithm 7.4.2. Fix a striped n -bipartition (λ, ϵ, μ) and let $(\lambda, \epsilon, \tilde{\mu})$ be the corresponding minimal bipartition. Define (α, β, γ) to be the zero colored bipartition: $\alpha = 0, \beta = 0, \gamma = 0$. As long as $\lambda \neq 0$, there are three mutually exclusive cases:

1. If there is an integer $i_0 > 1$ such that $\mu_{i_0} \geq \mu_i$ for all i then define

$$\begin{aligned} (\lambda', \epsilon', \mu') &= \Delta_1(\lambda, \epsilon, \mu), \\ \alpha'_i &= \begin{cases} \alpha_i & i \neq l(\alpha) + 1 \\ \lambda_1 & i = l(\alpha) + 1 \end{cases} \\ \beta'_i &= \begin{cases} \beta_i & i \neq l(\alpha) + 1 \\ \epsilon_1 & i = l(\alpha) + 1 \end{cases} \\ \gamma'_i &= \begin{cases} \gamma_i & i \neq l(\alpha) + 1 \\ \delta_1 & i = l(\alpha) + 1 \end{cases} \end{aligned}$$

In other words, we have removed the first row of (λ, ϵ, μ) and placed it at the end of (α, β, γ) , but with the mark from δ .

2. If $\mu_1 > \mu_i$ for all $i > 1$ and $\lambda_1 = \lambda_2$, define $(\lambda', \epsilon', \mu')$ by swapping the first two rows of (λ, ϵ, μ) and set $(\alpha', \beta', \gamma') = (\alpha, \beta, \gamma)$.

3. If $\mu_1 > \mu_i$ for all $i > 1$ and $\lambda_1 > \lambda_2$ then define $(\alpha', \beta', \gamma') = (\alpha, \beta, \gamma)$ and

$$\begin{aligned}\lambda'_i &= \begin{cases} \lambda_1 - 1 & i = 1 \\ \lambda_i & i > 1 \end{cases} \\ \epsilon'_i &= \epsilon_i \\ \mu'_i &= \begin{cases} \mu_1 - 1 & i = 1 \\ \mu_i & i > 1 \end{cases}\end{aligned}$$

In other words, we have removed the leftmost block from the first row of (λ, ϵ, μ) . Reorder, as necessary.

Replace (λ, ϵ, μ) , δ , and (α, β, γ) with $(\lambda', \epsilon', \mu')$, δ' , and $(\alpha', \beta', \gamma')$, respectively, and repeat until $\lambda = 0$. At this point, the algorithm returns the marked colored partition (α, β, γ) .

Lemma 7.4.3. *Let (λ, ϵ, μ) be a minimal bipartition. Then for each i there is j (possibly $j = i$) such that $\epsilon_j + \lambda_j - \mu_i = 0$ and either $\mu_j = \mu_i$ or $\lambda_j - \mu_j = \lambda_i - \mu_i$.*

Proof. Let $(\lambda, \epsilon, \tilde{\mu})$ be the corresponding striped n -bipartition and define

$$\mu'_l = \begin{cases} \mu_l - 1 & \text{if } \mu_l = \mu_i \text{ or } \lambda_l - \mu_l = \lambda_i - \mu_i, \\ \mu_l & \text{otherwise.} \end{cases}$$

Clearly, $\mu' < \mu$ and a simple case-by-case analysis shows that $(\lambda, \epsilon, \mu')$ is a colored bipartition. Minimality of (λ, ϵ, μ) , however, forces $\mu' \not\geq \tilde{\mu}$. So, there is at least one j such that $\mu'_j < \tilde{\mu}_j$. But $\mu_j - 1 \leq \mu'_j < \tilde{\mu}_j \leq \mu_j$. Therefore, $\mu'_j = \mu_j - 1$, so either $\mu_j = \mu_i$ or $\lambda_j - \mu_j = \lambda_i - \mu_i$. The same inequality shows that $\mu_j = \tilde{\mu}_j$, so

$$\epsilon_j + \lambda_j - \mu_i = \epsilon_j + \lambda_j - \tilde{\mu}_i = 0. \quad \square$$

Proposition 7.4.4. *Let (λ, ϵ, μ) be a striped n -bipartition and let (α, β, γ) be the result of algorithm 7.4.2. Fix $(v, x) \in \mathcal{O}_{\lambda, \epsilon, \mu}$ and set $\bar{V} = V/\mathbb{F}[x](v)$, $\overline{E^x v} = (E^x v)/\mathbb{F}[x](v)$. Then*

1. (α, β, γ) is a colored bipartition.
2. (α, β) is the colored Jordan type of $\bar{x} = x|_{\bar{V}}$,

3. The colored Jordan type of $x|_{\overline{E^{xv}}}$ is $(\gamma, \beta + [\alpha - \gamma])$,

4. The colored Jordan type of $x|_{\overline{V}/\overline{E^{xv}}}$ is $(\alpha - \gamma, \beta)$.

Proof. We prove this result by induction in $l(\lambda)$. For the inductive step, assume that (λ, ϵ, μ) is a striped n -bipartition with minimal bipartition $(\lambda, \epsilon, \tilde{\mu})$ and that (α, β, γ) is a colored bipartition satisfying $\gamma_i \geq \tilde{\mu}_j$ and $\alpha_i - \gamma_i \geq \lambda_j - \tilde{\mu}_j$ for each i, j such that $\lambda_j \neq 0$ and $\alpha_i \neq 0$. Let $\mathcal{B} = \{v_{i,j}\}$ be a normal basis for $(v, x) \in \mathcal{O}_{\lambda, \epsilon, \mu}$. Set $W_0 = \mathbb{F}[x](v)$ and if $w \in V$ then \bar{w} denotes the coset $w + W_0$.

Assume first that there is $i_0 > 1$ with $\mu_{i_0} \geq \mu_i$ for each i . We may take i_0 to be maximal. We know that $\{w_i = \sum_{j=1}^{\infty} v_{j,i} \mid i = 1, \dots, \mu_{i_0}\}$ is a basis for W_0 . Because $i_0 > 1$, $v_{1,1}$ is not in the span of these vectors, so $\bar{v}_{1,1}$ is nonzero in \overline{V} . Since λ_1 is the length of the longest Jordan block for x , no Jordan block for \bar{x} can be longer than λ_1 . The algorithm in proposition 3.3.3 indicates that, because $\bar{v}_{1,1}, \dots, \bar{v}_{1,\lambda_1}$ form a maximal colored Jordan block for \bar{x} , we can conclude that the colored Jordan form of \bar{x} contains a block of type (λ_1, ϵ_1) , with the rest determined inductively by the colored Jordan form of $\bar{x}|_{\overline{V}/\langle \bar{v}_{1,1}, \dots, \bar{v}_{1,\lambda_1} \rangle}$. So, we can delete the first row from (λ, ϵ, μ) and copy it to (α, β, γ) .

It is obvious that $(\lambda', \epsilon', \mu')$ defined above is a striped n -bipartition. We just need to compute $(\lambda', \epsilon', \tilde{\mu}')$:

$$\begin{aligned} \tilde{\mu}'_i &= \max(\{\mu'_j \mid j \geq i\} \cup \{\lambda'_i - (\lambda'_j - \mu_j) \mid 1 \leq j < i\}) \\ &= \max(\{\mu_{j+1} \mid j \geq i\} \cup \{\lambda_{i+1} - (\lambda_{j+1} - \mu_{j+1}) \mid 1 \leq j < i\}) \\ &= \max(\{\mu_{j+1} \mid j + 1 \geq i + 1\} \cup \{\lambda_{i+1} - (\lambda_{j+1} - \mu_{j+1}) \mid 2 \leq j + 1 < i + 1\}) \\ &= \max(\{\mu_j \mid j \geq i + 1\} \cup \{\lambda_{i+1} - (\lambda_j - \mu_j) \mid 2 \leq j < i + 1\}). \end{aligned}$$

Observe the similarity of the above formula to the formula for $\tilde{\mu}_{i+1}$. Indeed, it is clear that $\tilde{\mu}_{i+1} = \max\{\tilde{\mu}'_i, \lambda_{i+1} - (\lambda_1 - \mu_1)\}$. We wish to see that $\tilde{\mu}'_i = \tilde{\mu}_{i+1}$, so we just need to argue that $\tilde{\mu}'_i \geq \lambda_{i+1} - \lambda_1 + \mu_1$ for each i . This effort is divided into three cases:

1. If $1 \leq i < i_0$ then maximality of μ_{i_0} forces

$$\lambda_i - \lambda_1 + \mu_1 \leq (\lambda_i - \lambda_1) + \mu_{i_0} \leq \mu_{i_0} = \mu_{i_0-1} \leq \tilde{\mu}'_{i-1}.$$

2. If $i = i_0$ then maximality of μ_{i_0} and i_0 , together with lemma 7.4.3, force

$$\tilde{\mu}'_{i-1} = \mu_{i_0} = \tilde{\mu}_i.$$

3. If $i > i_0$ then

$$\begin{aligned}
\lambda_i - \lambda_1 + \mu_1 &\leq \lambda_i - \lambda_{i_0} + \mu_{i_0} \\
&= \lambda_i - (\lambda_{i_0} - \mu_{i_0}) \\
&= \lambda'_{i-1} - (\lambda'_{i_0-1} - \mu'_{i_0-1}) \\
&\leq \tilde{\mu}'_{i-1}.
\end{aligned}$$

Since $\tilde{\mu}'_i \geq \lambda_{i+1} - \lambda_1 + \mu_1$ for each i , we conclude that $\tilde{\mu}'_i = \tilde{\mu}_{i+1}$. In other words, just as $(\lambda', \epsilon', \mu')$ is built from (λ, ϵ, μ) by deleting the first row, the corresponding minimal bipartition is built in the same way: $(\lambda', \epsilon', \tilde{\mu}')$ is just $(\lambda, \epsilon, \tilde{\mu})$ with the first row deleted. Therefore, $(\lambda', \epsilon', \mu')$, $(\lambda', \epsilon', \tilde{\mu}')$, and $(\alpha', \beta', \gamma')$ satisfy the inductive hypotheses and we can proceed.

Now, if $\mu_1 > \mu_i$ for all $i > 1$ and $\lambda_1 = \lambda_2$ then we may reorder the first two rows to find ourselves in the first case. Clearly, this change has no impact on the inductive hypotheses.

Lastly, if $\mu_1 > \mu_i$ for all $i > 1$ and $\lambda_1 > \lambda_2$ then we conclude that $\bar{v}_{1,1} = 0$. Therefore, (λ, ϵ, μ) and $(\lambda', \epsilon', \mu')$ induce the same quotient. That is,

$$x|_{V/\mathbb{F}[x](v)} = x|_{(V/\langle v_{1,1} \rangle)/(\mathbb{F}[x](v)/\langle v_{1,1} \rangle)}.$$

We also see that $\tilde{\mu} - \tilde{\mu}' = \lambda - \lambda'$, so $\lambda - \tilde{\mu} = \lambda' - \tilde{\mu}'$. Noting that $\tilde{\mu}' \leq \tilde{\mu}$, we conclude that $(\lambda', \epsilon', \mu')$, $(\lambda', \epsilon', \tilde{\mu}')$, and (α, β, γ) satisfy the inductive hypotheses and we may proceed, concluding that (α, β, γ) is a colored bipartition.

The second claim (that (α, β) is the colored Jordan type of \bar{x}) is clear. The algorithm should make it clear that $\xi(\alpha, \beta) = \xi(\lambda, \epsilon) - \xi(\mathbb{F}[x](v))$ and that $\xi(\alpha - \gamma, \beta) = \xi(\lambda - \mu, \epsilon)$, so $\xi(\gamma, \epsilon + [\lambda - \gamma]) = \xi(\mu, \epsilon + [\lambda - \mu]) - \xi(\mathbb{F}[x](v))$. Claim 4 follows because each step of the algorithm preserves the right side of the diagram, up to order. Claim 3 is also straightforward because the left side of the original diagram is a basis for $E^x v$. The effect of each step in the algorithm that changes the left side (other than order) is the same as if we were to apply the algorithm in proposition 3.3.3 to $E^x v$. \square

Proof of proposition 7.4.1. Let $(v, x) \in \mathcal{O}_{\lambda, \epsilon, \mu}$, $(u, y) \in \mathcal{O}_{\alpha, \beta, \gamma}$, $\bar{x} = x|_{V/\mathbb{F}[x](v)}$, and $\bar{y} = y|_{V/\mathbb{F}[y](u)}$. Then $R_f(\bar{x}) = R_f(x) - R_0(v, x) = R_f(x) - R_0(u, y) \geq R_f(y) - R_0(u, y) = R_f(\bar{y})$, so $\bar{y} \in \overline{\mathcal{O}_{\bar{x}}}$. Since (α, β) is the colored Jordan type of \bar{x} and (α, β, γ) is a bipartition, there is a \bar{y} -stable subspace $\overline{W} \subset \overline{V}$ of signature $\xi(\gamma, \epsilon + [\lambda - \gamma]) = \xi(\mu, \epsilon + [\lambda - \mu]) - \xi(\mathbb{F}[x](v))$ such that $\bar{y}|_{\overline{W}} \leq (\gamma, \beta + [\alpha - \gamma])$ and $\bar{y}|_{\overline{V}/\overline{W}} \leq (\alpha - \gamma, \beta)$.

Lift \overline{W} to $W \subset V$. It is clear that $\xi(W) = \xi(\mathbb{F}[x](v)) + \xi(\gamma, \epsilon + [\lambda - \gamma]) = \xi(\mu, \epsilon + [\lambda - \mu])$ and that W is y -stable. We just need to argue that $y|_W \leq x|_{E^{x_v}}$ and that $y|_{V/W} \leq x|_{V/E^{x_v}}$. The latter is trivial, as $y|_{V/W} = \bar{y}|_{\overline{V/W}} \leq \bar{x}|_{\overline{V/E^{x_v}}} = x|_{V/E^{x_v}}$. The former is not too difficult, either, but it requires a bit more care.

We know that $\mathbb{F}[y](v)$ is a maximal Jordan block for $y|_W$, since $d_y(v) \geq d_y(u)$ for each $u \in W$. Therefore, the colored Jordan form of $y|_W$ has $(d_y(v), [0])$ as a row, with the other rows being precisely the rows of the colored Jordan form of $\bar{y}|_{\overline{W}}$. At the same time, $x|_{E^{x_v}}$ clearly has a row of the form $(d_y(v), [0])$, since $d_y(v) = d_x(v) = \dim \mathbb{F}[x](v)$. If we delete these rows, we have the diagrams for $\bar{y}|_{\overline{W}}$ and $\bar{x}|_{\overline{V/E^{x_v}}}$. But we know that $\bar{y}|_{\overline{W}} \leq \bar{x}|_{\overline{V/E^{x_v}}}$, so lemma 6.3.5 forces $y|_W \leq x|_{E^{x_v}}$ and we are done. \square

7.5 Same-shape pairs

In this section, we prove conjecture 7.3.4 in the case where two striped n -bipartitions have the same shape.

Lemma 7.5.1. *If (λ, ϵ) is a colored partition and f is the signature of row i then*

$$f(m) = \left\lfloor \frac{\lambda_i - \langle m - \epsilon_i \rangle}{n} \right\rfloor = \begin{cases} \left\lfloor \frac{\lambda_i}{n} \right\rfloor & \langle m - \epsilon_i \rangle \leq n - \langle -\lambda_i \rangle, \\ \left\lfloor \frac{\lambda_i}{n} \right\rfloor & \text{otherwise.} \end{cases}$$

Let (λ, ϵ, μ) be a striped n -bipartition. Fix colors $l, r \in \mathbb{Z}/n\mathbb{Z}$. For each $i \in \mathbb{N}$ let $t_i = \langle r - \epsilon_i \rangle$ and $s_i = \langle \epsilon_i + [\lambda_i - 1] - l \rangle$. We can define a new marked colored partition (α, β, γ) by the formulas

$$\begin{aligned} \alpha_i &= \begin{cases} \lambda_i - t_i - s_i & \lambda_i - t_i - s_i > 0 \\ 0 & \text{otherwise.} \end{cases} \\ \beta_i &= r \\ \gamma_i &= \begin{cases} \mu_i - s_i & \mu_i > s_i \\ 0 & \text{otherwise.} \end{cases} \end{aligned}$$

The diagram for (α, β, γ) is obtained from the diagram for (λ, ϵ, μ) by trimming the fewest boxes possible from each end of each row so that the rightmost box has color r and the leftmost box has color l . Note that α may not be a partition, so reordering of (α, β, γ) may be necessary.

Lemma 7.5.2. *Let (λ, ϵ, μ) be a marked colored partition such that $\epsilon + [\lambda - \mu] = 0$ and let $l, r \in \mathbb{Z}/n\mathbb{Z}$. If (α, β, γ) is as constructed above then for each $k \in \mathbb{Z}^{\geq 0}$ we have*

1. $R_{r,k}(\lambda, \epsilon)(l) = R_{r,k}(\alpha, \beta)(l)$,
2. $R_{r,k}(\lambda, \epsilon, \mu)(l) = R_{r,k}(\alpha, \beta, \gamma)(l)$.

Proof. Fix $x \in \mathcal{O}_{\lambda, \epsilon}$ and set $U = \ker x \cap \bigoplus_{i \neq l} V_i$. We observe that U is x -stable, so we can construct $\bar{x} = x|_{V/U}$. Let $A \subset V_r$ be a subspace of dimension k such that $W = \mathbb{F}[x](A)$ has maximal signature. Then W/U is an x -stable subspace of V/U generated by $(A + U)/U$, a k -dimensional subspace of $(V_r + U)/U$. Maximality of R_f forces

$$\begin{aligned}
R_{r,k}(\bar{x})(l) &\geq \xi_l((W + U)/U) \\
&= \xi_l(W) - \xi_l(W \cap U) \\
&= R_{r,k}(x)(l) - \dim(W \cap U \cap V_l) \\
&= R_{r,k}(x)(l) - \dim(W \cap 0) \\
&= R_{r,k}(x)(l).
\end{aligned}$$

Conversely, suppose that A/U is a subspace of $(V_r + U)/U$ of dimension k such that $\mathbb{F}[\bar{x}](A/U)$ has maximal signature. Lift to $A \subset V$ and set $W = \mathbb{F}[x](A \cap V_r)$. $\mathbb{F}[\bar{x}](A/U)$ lifts to $\mathbb{F}[x](A + U) = W + U$. Since $U \cap V_l = 0$, proposition 6.4.6 tells us that

$$\begin{aligned}
R_{r,k}(x)(l) &\geq \dim(W \cap V_l) \\
&= \dim(((W \cap V_l) \oplus U)/U) \\
&= \dim(((W + U) \cap (V_l + U))/U) \\
&= \dim(((W + U)/U) \cap ((V_l + U)/U)) \\
&= R_{r,k}(\bar{x})(l).
\end{aligned}$$

Therefore, $R_{r,k}(\bar{x})(l) = R_{r,k}(x)(l)$. This process shows that we may remove all boxes in the leftmost column whose color is not l . By repeated application of this procedure, we see that we can trim on the left as prescribed.

To see that we can also trim on the right side, we only need to observe that it is enough to consider subspaces of $\mathbb{F}[x](V_r)$. The proof needs little modification to prove the second claim. \square

Lemma 7.5.3. *Let $l, r \in \mathbb{Z}/n\mathbb{Z}$ and let (λ, ϵ, μ) be a striped n -bipartition with $\epsilon_i = r$ and $\epsilon_i + [\lambda_i - 1] = l$ whenever $\lambda_i \neq 0$. If $k \geq 0$ is an integer then*

1. (λ, ϵ, μ) is a colored bipartition.

$$2. R_{r,k}(\lambda, \epsilon)(l) = \sum_{i=1}^k \left\lceil \frac{\lambda_i}{n} \right\rceil.$$

$$3. R_{r,k}(\lambda, \epsilon, \mu)(l) = \left\lceil \frac{\mu_{k+1}}{n} \right\rceil + \sum_{i=1}^k \left\lceil \frac{\lambda_i}{n} \right\rceil.$$

Proof.

1. Assume that $i < j$. Then $[\mu_i] = \epsilon_i + [\lambda_i] = \epsilon_j + [\lambda_j] = [\mu_j]$, so there is an integer p such that $\mu_i = \mu_j + p \cdot n$. By definition of striped n -bipartition, $\mu_j < \mu_i + n = \mu_j + p \cdot n + n$, hence $0 < (p+1)n$. It follows that $p > -1$, so $p \geq 0$ and we conclude that $\mu_i \geq \mu_j$. The argument that $\lambda_i - \mu_i \geq \lambda_j - \mu_j$ is entirely analogous.
2. Fix a colored basis $\mathcal{B} = \{v_{i,j}\}$ for $x \in \mathcal{O}_{\lambda,\epsilon}$. It is clear that $\langle \{v_{i,j} \mid 1 \leq i \leq k\} \rangle$ is x -stable and generated by $W = \langle \{v_{i,\lambda_i} \mid 1 \leq i \leq k\} \rangle$, a k -dimensional subspace of V_r . Since the left-end and right-end colors of each row are identical, it should be clear that W is maximal with this property. The formula from lemma 7.5.1 finishes the proof.
3. If $(v, x) \in \mathcal{O}_{\lambda,\epsilon,\mu}$ then $\dim \mathbb{F}[x](v) = \mu_1$, so $\xi(\mathbb{F}[x](v))(l) = \left\lceil \frac{\mu_1}{n} \right\rceil$. It is also true that if (λ', ϵ') is the colored Jordan type of $x|_{V/\mathbb{F}[x](v)}$ then $\epsilon' = \epsilon$ and $\lambda'_i = \lambda_i - \mu_i + \mu_{i+1}$. Visually, $\mathbb{F}[x](v)$ is the left half of the first row of the diagram for (λ, ϵ, μ) . The diagram of (λ', ϵ') is built by deleting the left half of the first row of the diagram for (λ, ϵ, μ) , shifting all of the left halves of the rows up one row, and deleting the marks.

From part (2), plus the fact that $\mu_i - \mu_j$ is a multiple of n for each i, j ,

$$\begin{aligned} R_{r,k}(\lambda, \epsilon, \mu) &= \left\lceil \frac{\mu_1}{n} \right\rceil + \sum_{i=1}^k \left\lceil \frac{\lambda_i - \mu_i + \mu_{i+1}}{n} \right\rceil \\ &= \left\lceil \frac{\mu_1}{n} \right\rceil + \sum_{i=1}^k \left\lceil \frac{\lambda_i}{n} \right\rceil + \sum_{i=1}^k \frac{-\mu_i + \mu_{i+1}}{n} \\ &= \left\lceil \frac{\mu_1}{n} \right\rceil + \sum_{i=1}^k \left\lceil \frac{\lambda_i}{n} \right\rceil + \frac{-\mu_1 + \mu_{k+1}}{n}. \\ &= \left\lceil \frac{\mu_1}{n} + \frac{-\mu_1 + \mu_{k+1}}{n} \right\rceil + \sum_{i=1}^k \left\lceil \frac{\lambda_i}{n} \right\rceil. \\ &= \left\lceil \frac{\mu_{k+1}}{n} \right\rceil + \sum_{i=1}^k \left\lceil \frac{\lambda_i}{n} \right\rceil, \end{aligned}$$

completing the proof. \square

Proposition 7.5.4. *If (λ, ϵ, μ) and $(\lambda, \epsilon, \delta)$ are striped n -bipartitions of the same shape and $R_{m,k}(\lambda, \epsilon, \delta) \leq R_{m,k}(\lambda, \epsilon, \mu)$ for all $(m, k) \in \mathbb{Z}/n\mathbb{Z} \times \mathbb{Z}^{\geq 0}$ then $\delta_i \leq \mu_i$ for each i . In particular, $\mathcal{O}_{\lambda, \epsilon, \delta} \leq \mathcal{O}_{\lambda, \epsilon, \mu}$.*

Proof. Fix $k \in \mathbb{N}$. The result will follow from lemma 7.5.3, once we make a careful choice of l and m . Let $t = \min\{\lambda_i - \mu_i \mid \lambda_i \geq \lambda_k\}$ and set $m = \lfloor -t \rfloor$. Similarly, set $l = \lfloor \mu_k - 1 \rfloor$. Let (α, β, γ) and (α, β, τ) be the results of trimming (λ, ϵ, μ) and $(\lambda, \epsilon, \delta)$, respectively, as in lemma 7.5.2. The key feature of our choice of l and m is that $\tilde{\gamma}_k = \gamma_k = \mu_k$ and $\tau_k = \delta_k$.

Reordering, we may assume that α is a partition. The formula in lemma 7.5.3 shows that for each $j \geq 0$ we have

$$\left\lfloor \frac{\tilde{\gamma}_j}{n} \right\rfloor + \sum_{i=1}^{j-1} \left\lfloor \frac{\lambda_i}{n} \right\rfloor \geq \left\lfloor \frac{\tilde{\tau}_j}{n} \right\rfloor + \sum_{i=1}^{j-1} \left\lfloor \frac{\lambda_i}{n} \right\rfloor,$$

so $\left\lfloor \frac{\tilde{\gamma}_j}{n} \right\rfloor \geq \left\lfloor \frac{\tilde{\tau}_j}{n} \right\rfloor$. But $\lfloor \tilde{\gamma}_j \rfloor = \lfloor \tilde{\tau}_j \rfloor$, so $\tilde{\gamma}_j \geq \tilde{\tau}_j \geq \tau_j$. This inequality is independent of the reordering we did a moment ago, so we conclude that $\tilde{\gamma}_k \geq \tau_k$, before reordering. Therefore, $\mu_k = \gamma_k \geq \tilde{\gamma}_k \geq \tau_k = \delta_k$.

The fact that $\mathcal{O}_{\lambda, \epsilon, \delta} \leq \mathcal{O}_{\lambda, \epsilon, \mu}$ will follow from corollary 8.1.2. \square

CHAPTER 8

ENHANCED COVERING RELATIONS

In this section we wish to enhance our understanding of the enhanced closure order by studying the combinatorial operations that generate the closure order.

8.1 Same-shape covering relations

We begin by investigating when a closure relation exists between two orbits of the same shape. Fix minimal colored bipartitions (λ, ϵ, μ) and $(\lambda, \epsilon, \delta)$ of the same shape. Since they have the same shape we may let $(v, x) \in \mathcal{O}_{\lambda, \epsilon, \mu}$, $(w, x) \in \mathcal{O}_{\lambda, \epsilon, \delta}$. That is, we take the representatives to have the same nilpotent component.

Assume that $\mathcal{O}_{\lambda, \epsilon, \delta} \leq \mathcal{O}_{\lambda, \epsilon, \mu}$. By proposition 7.1.3 this is equivalent to the existence of a flag (W_k) such that $\xi(W_k) = \xi(W_k^{v,x})$ and $xW_k \subset W_{k-1}$. From the proof of theorem 7.1.2 we know that the only possibility is $W_k = W_k^{v,x}$. Therefore, $\mathcal{O}_{\lambda, \epsilon, \delta} \leq \mathcal{O}_{\lambda, \epsilon, \mu}$ if and only if $w \in W_{\mu_1}^{v,x} = E^x v$. Since $w \in V_0$ we conclude that the minimal colored bipartitions orbits of shape (λ, ϵ) that are in $\overline{\mathcal{O}}_{\lambda, \epsilon, \mu}$ are precisely those $(\lambda, \epsilon, \delta)$ that satisfy $\delta \leq \mu$.

Proposition 8.1.1. *If (λ, ϵ, μ) and $(\lambda, \epsilon, \delta)$ are minimal colored bipartitions then $\mathcal{O}_{\lambda, \epsilon, \delta} \leq \mathcal{O}_{\lambda, \epsilon, \mu}$ if and only if $\delta \leq \mu$.*

It is convenient here to revert to the parametrization of orbits by striped n -bipartitions. Let (λ, ϵ, μ) and $(\lambda, \epsilon, \delta)$ be striped n -bipartitions and $(\lambda, \epsilon, \tilde{\mu})$ $(\lambda, \epsilon, \tilde{\delta})$ their respective minimal bipartitions. From lemma 4.1.2 we know that $0 \leq \tilde{\mu}_i - \mu_i < n$ and $0 \leq \tilde{\delta}_i - \delta_i < n$. If $\tilde{\delta} \leq \tilde{\mu}$ then $\tilde{\mu}_i \geq \tilde{\delta}_i$ for each i . Therefore, $\delta_i \leq \tilde{\delta}_i \leq \tilde{\mu}_i < \mu_i + n$, hence $\delta_i < \mu_i + n$. But $\delta_i \equiv \mu_i \pmod{n}$, so $\delta_i \leq \mu_i$. On the other hand, the formula for $\tilde{\mu}$ in lemma 4.1.2 makes it clear that if $\delta \leq \mu$ then $\tilde{\delta} \leq \tilde{\mu}$ and we conclude the following.

Corollary 8.1.2. *If $(\lambda, \epsilon, \mu), (\lambda, \epsilon, \delta)$ are striped n -bipartitions then $\mathcal{O}_{\lambda, \epsilon, \delta} \leq \mathcal{O}_{\lambda, \epsilon, \mu}$ if and only if $\delta \leq \mu$.*

We wish now to describe the covering relations among colored striped n -bipartitions of the same shape. That is, for a fixed striped n -bipartition (λ, ϵ, μ) , we wish to understand for which striped n -bipartitions $(\lambda, \epsilon, \delta) < (\lambda, \epsilon, \mu)$ there does not exist a striped n -bipartition $(\lambda', \epsilon', \mu')$ such that $(\lambda, \epsilon, \delta) < (\lambda', \epsilon', \mu') < (\lambda, \epsilon, \mu)$. First, note that if $(\lambda, \epsilon, \delta) < (\lambda', \epsilon', \mu') < (\lambda, \epsilon, \mu)$ then lemma 7.2.1 forces $(\lambda, \epsilon) \leq (\lambda', \epsilon') \leq (\lambda, \epsilon)$, so (λ', ϵ') and (λ, ϵ) are equivalent. Thus, we need only consider striped n -bipartitions of the same shape.

Fix a positive integer i_0 such that $\mu_{i_0} > 0$ and define

$$\delta_i = \begin{cases} \mu_{i_0} - n & \text{if } i = i_0 \\ \mu_i & \text{otherwise.} \end{cases}$$

Under what circumstances is $(\lambda, \epsilon, \delta)$ a striped n -bipartition? It is clear that δ is a marking of λ that satisfies $\delta_i > -n$ for each i and $\epsilon + [\lambda - \delta] = 0$. We just need to verify the other inequalities. Since δ only differs from μ in one position, we need only investigate pairs $j < i$ with $i_0 \in \{i, j\}$.

If $i_0 = i$ then $\delta_{i_0} = \mu_{i_0} - n \leq (\mu_j + n) - n < \mu_j + n = \delta_j + n$. If $i_0 = j$ then $\lambda_{i_0} - \delta_{i_0} + n = \lambda_{i_0} - (\mu_{i_0} - n) + n = (\lambda_{i_0} - \mu_{i_0} + n) + n \geq \lambda_i - \mu_i + n > \lambda_i - \mu_i = \lambda_i - \delta_i$. Therefore, the only cases in which $(\lambda, \epsilon, \delta)$ fails to be a striped n -bipartition are when there is a pair $j < i$ such that either $\mu_i \geq \mu_j$ or $\lambda_i - \mu_i \geq \lambda_j - \mu_j$.

In the first case we cannot reduce μ_j without also reducing μ_i . In the second, we cannot reduce μ_i without also reducing μ_j . In the first case, we could try to correct this by trying to reduce μ_i instead. Once that move is done, we could then proceed to reduce μ_j . However, there could potentially be a third row $k < j$ with $\mu_k \leq \mu_j$, in which case we end up with the same problem. We might wonder if there will EVER be a single row where we can reduce μ , or if there may always be collections of rows that must be moved together. The answer to this question is the content of the next proposition.

A particular case to consider is the existence of a pair $j < i$ with BOTH $\mu_i \geq \mu_j$ and $\lambda_i - \mu_i \geq \lambda_j - \mu_j$. Since $j < i$ we must have $\lambda_j \geq \lambda_i \geq \lambda_j + \mu_i - \mu_j \geq \lambda_j$, hence $\lambda_j = \lambda_i$ and $\mu_j = \mu_i$. But $\epsilon_j + \lambda_j - \mu_j = 0 = \epsilon_i + \lambda_i - \mu_i = \epsilon_i + \lambda_j - \mu_j$, hence $\epsilon_j = \epsilon_i$. In other words, if both conditions hold then rows i and j are identical. On the other hand, if rows i and j are identical then the striped n -bipartition inequalities force $\mu_i = \mu_j$, hence $\lambda_i - \mu_i = \lambda_j - \mu_j$. It is clear, therefore, that if rows i and j are identical then we must always move them together. That is, if we redefine μ_i then we must also redefine $\mu_j = \mu_i$.

Definition 8.1.3. A *type III move*, or *slide* is performed on a striped n -bipartition (λ, ϵ, μ) as follows, resulting in a new striped n -bipartition $(\lambda, \epsilon, \delta)$. Define

$$\delta_i = \begin{cases} \mu_{i_0} - n & \text{if } \lambda_i = \lambda_{i_0} \text{ and } \epsilon_i = \epsilon_{i_0} \\ \mu_i & \text{otherwise,} \end{cases}$$

where i_0 is a positive integer such that

1. $\mu_{i_0} > 0$,
2. $\mu_i < \mu_{i_0}$ for all $i > i_0$,
3. $\lambda_i - \mu_i > \lambda_{i_0} - \mu_{i_0}$ for all $i < i_0$, unless $\lambda_i = \lambda_{i_0}$ and $\epsilon_i = \epsilon_{i_0}$.

Proposition 8.1.4. Let (λ, ϵ, μ) be a striped n -bipartition and let $(\lambda, \epsilon, \delta)$ be the result of a type III move applied to (λ, ϵ, μ) . Then

1. $(\lambda, \epsilon, \delta)$ is a striped n -bipartition satisfying $(\lambda, \epsilon, \delta) < (\lambda, \epsilon, \mu)$.
2. There is no μ' such that $(\lambda, \epsilon, \delta) < (\lambda, \epsilon, \mu') < (\lambda, \epsilon, \mu)$,
3. If $(\lambda, \epsilon, \mu') < (\lambda, \epsilon, \mu)$ is a striped n -bipartition there is a type III move applied to (λ, ϵ, μ) resulting in a $(\lambda, \epsilon, \delta)$ such that $(\lambda, \epsilon, \mu') < (\lambda, \epsilon, \delta)$.

Proof. The proofs of (1) and (2) are obvious, so we omit them here.

To prove part (3), we begin by constructing a convenient graph that encodes the obstructions to reducing μ that we observed above. Let $\Gamma = \Gamma(\lambda, \epsilon, \mu)$ be the graph with (finite) vertex set $\{i \in \mathbb{N} \mid \mu_i > 0\}$ and directed edges (i, j) where either

1. $i > j$ and $\mu_i \geq \mu_j$ or
2. $i < j$ and $\lambda_i - \mu_i \leq \lambda_j - \mu_j$.

As is customary, a directed path in Γ from i to j is a sequence $i = i_0, i_1, \dots, i_k = j$, where (i_r, i_{r+1}) is an edge in Γ for each $0 \leq r < k$. The length of the path is k . If such a path exists, we will write $i \rightarrow j$. Clearly, the relation $i \rightarrow j$ is reflexive and transitive. If $i \rightarrow j$ then we define $d(i, j)$ to be the length of any shortest directed path in Γ from i to j .

In terms of the original problem, $i \rightarrow j$ if and only if we cannot reduce μ_i without reducing μ_j while preserving the n -bipartition structure. Thus, the strongly connected components of Γ are precisely the set of rows i that must be reduced together, if at all.

We have seen that if two rows are identical then they lie in the same component. Our goal is to show that the converse is true.

Based on the remarks preceding definition 8.1.3, plus a few simple calculations, we make the following observations:

1. $d(i, j) = 0 \iff i = j \iff d(j, i) = 0$.
2. $d(i, j) = d(j, i) = 1$ if and only if $\lambda_i = \lambda_j$ and $\mu_i = \mu_j$.
3. $d(i, k) \leq d(i, j) + d(j, k)$ if $i \rightarrow j \rightarrow k$.
4. Assume that $d(i, j) = d(j, i) = 1$. If $i \rightarrow k$ then $d(i, k) = d(j, k)$. If $k \rightarrow i$ then $d(k, i) = d(k, j)$.
5. If i_0, i_1, \dots, i_k is a path of minimal length and $0 \leq r \leq s \leq k$ then $i_r \rightarrow i_s$ and $d(i_r, i_s) = s - r$.

Now, we investigate some properties of minimal paths. Assume that $d(i, j) = d(j, k) =$

1. If $\mu_k \geq \mu_j \geq \mu_i$ (resp. $\lambda_k - \mu_k \geq \lambda_j - \mu_j \geq \lambda_i - \mu_i$) then $k > i$ and $\mu_k \geq \mu_i$ (resp. $\lambda_k - \mu_k \geq \lambda_i - \mu_i$). Therefore, $d(i, k) \leq 1$. We conclude that if i, j, k is a minimal path ($d(i, k) = 2$) then either

- $k > j < i$ ($\mu_k \geq \mu_j$ and $\lambda_j - \mu_j \leq \lambda_i - \mu_i$), or
- $k < j > i$ ($\mu_j \geq \mu_i$ and $\lambda_k - \mu_k \leq \lambda_j - \mu_j$).

In the first case, $\mu_k \geq \mu_j \geq \lambda_j - \lambda_i + \mu_i \geq \mu_i$. If $i > k$ then $d(i, k) \leq 1$. In the second case, $\lambda_k - \mu_k \leq \lambda_j - \mu_j \leq \lambda_i - \mu_i$. Again, if $i > k$ then $d(i, k) \leq 1$. In either case, we conclude that $i < k$. In other words, if i_0, i_1, \dots, i_k is a minimal path then $i_r < i_{r+2}$ whenever $0 \leq r < k - 1$.

Suppose that $i \rightarrow j \rightarrow i$ and that $d(i, j) = 1$, but $d(j, i) = k > 1$. We may assume that k is minimal with this property. Let $j = i_0, \dots, i_k = i$ be a minimal path from j to i . Suppose that $i_k < i_1$ and $i_{k-1} < i_0$. If k is odd then $i_0 < i_2 < \dots < i_{k-1} < i_0$. If k is even then $i_0 < i_2 < \dots < i_k < i_1 < i_3 < \dots < i_{k-1} < i_0$. In either case, we have a contradiction.

Therefore, $i_1, \dots, i_k = i, i_0 = j$ is a path from i_1 to j (of length k) that is not minimal, hence $d(i_1, j) < k$, but $d(j, i_1) = 1$. By minimality of k , however, we must conclude that $d(i_1, j) = 1$. But then $k - 1 = d(i_1, i_k) = d(i_0, i_k) = (k - 0) = k$, a contradiction.

This proves the claim that if $i \rightarrow j \rightarrow i$ then $d(i, j) = d(j, i) = 1$. In other words, two rows of (λ, ϵ, μ) lie in the same strongly connected component of Γ if and only if they are identical.

Now, if $(\lambda, \epsilon, \mu') < (\lambda, \epsilon, \mu)$ then there must be some integer i such that $\mu'_i < \mu_i$. If, for this choice of i , $i \rightarrow j$ implies that $j \rightarrow i$ then apply a type III move to (λ, ϵ, μ) with $i_0 = i$. Otherwise, recall that the strongly connected components of a graph are partially ordered and Γ is finite. So, there must be a strongly connected component γ of Γ that satisfies $i \rightarrow j$ for each $j \in \gamma$ and is minimal with respect to this property. Perform a type III move on (λ, ϵ, μ) with i_0 any element of γ . \square

8.2 Types I and II

Definition 8.2.1. If (λ, ϵ, μ) is a striped n -bipartition then a *type I move*, or *left drop*, on (λ, ϵ, μ) is a left move (i, j, t) on (λ, ϵ) such that $\mu_j + t \leq \mu_i$. The result of the left move is the marked colored partition $(\alpha, \epsilon, \gamma)$ defined by

$$\alpha_k = \begin{cases} \lambda_i - t & k = i, \\ \lambda_k & k \neq i; \end{cases}$$

$$\gamma_k = \begin{cases} \mu_i - t & k = i, \\ \mu_k & k \neq i. \end{cases}$$

Definition 8.2.2. If (λ, ϵ, μ) is a striped n -bipartition then a *type II move*, or *right drop*, on (λ, ϵ, μ) is a right move (i, j, t) on (λ, ϵ) such that $\lambda_j - \mu_j + t \leq \lambda_i - \mu_i$. The result of the left move is the marked colored partition (α, β, μ) defined by

$$\alpha_k = \begin{cases} \lambda_i - t & k = i, \\ \lambda_k & k \neq i; \end{cases}$$

$$\beta_k = \begin{cases} \epsilon_j & k = i, \\ \epsilon_i & k = j, \\ \epsilon_k & k \neq i, j. \end{cases}$$

Pictorially, a type I move is to drop a segment from the left end of one row and place on the left end of a lower row, in such a way that the new lower row is shorter than the original upper row and the new left segment of the lower row is no longer than the original upper row. A type II move is similar, but on the right side of the diagram.

Proposition 8.2.3. *If (λ, ϵ, μ) is a striped n -bipartition and (i_0, j_0, t) is a move of type I or type II resulting in (α, β, γ) then $(\alpha, \beta, \gamma) < (\lambda, \epsilon, \mu)$.*

Proof. We will primarily make use of proposition 7.1.3. We will prove the result for a type I move; type II is similar.

Let $\mathcal{B} = \{v_{i,j}\}$ be a normal basis for (v, x) of type (λ, ϵ, μ) . Let $(\lambda, \epsilon, \tilde{\mu})$ be the associated minimal colored bipartition. Then $E^x v = \langle \mathcal{B}^{\tilde{\mu}} \rangle$.

We relabel the elements of \mathcal{B} :

$$w_{i,j} = \begin{cases} v_{i,j} & i \neq i_0, j_0; \\ v_{i_0, j+t} & i = i_0, 1 \leq j \leq \lambda_{i_0} - t = \alpha_{i_0}; \\ v_{i_0, j} & i = j_0, 1 \leq j \leq t; \\ v_{j_0, j-t} & i = j_0, t+1 \leq j \leq \lambda_{j_0} + t = \alpha_{j_0}. \end{cases}$$

If we define $yw_{i,j} = w_{i,j-1}$, $yw_{i,1} = 0$, $u = \sum_i v_{i,\gamma_i}$ then $(u, x) \in \mathcal{O}_{\alpha,\beta,\gamma}$. By proposition 7.1.3 we just need to construct an appropriate y -stable subspace $W \subset V$.

If $\tilde{\mu}_{j_0} + t \leq \tilde{\mu}_{i_0}$ then this is straightforward: we simply set $W = E^x v$. The construction makes it clear that $\xi(W) = \xi(E^x v)$, $u \in W$, and $yW \subset W$. What is more, $y|_{V/W} = x|_{V/W}$. We only need to verify that $y|_W \leq x|_W$. Because $\tilde{\mu}_{j_0} + t \leq \tilde{\mu}_{i_0}$, (i_0, j_0, t) is a left move on $x|_W$, so we are done.

If $\tilde{\mu}_{j_0} + t > \tilde{\mu}_{i_0}$, set

$$W = \langle \mathcal{B}^{\tilde{\mu}} \cup \{v_{i_0, j} \mid \tilde{\mu}_{i_0} + 1 \leq j \leq \tilde{\mu}_{j_0} + t\} \setminus \{v_{j_0, j} \mid \tilde{\mu}_{i_0} - t + 1 \leq j \leq \tilde{\mu}_{j_0}\} \rangle.$$

Because $\tilde{\mu}_{j_0} > \tilde{\mu}_{i_0} - t$, each vector in the third term of the above expression must have nonzero color. Therefore, W contains $E^x v \cap V_0$, hence v . Clearly, W is y -stable. By reordering rows, we find that $y|_W = x|_{E^x v}$. Lastly, $y|_{V/W}$ is obtained by a left move on $x|_{V/W}$, so we are done. \square

8.3 Future efforts

There remains considerable effort to prove conjecture 7.3.4, but there is strong evidence that the conjecture will be vindicated. We present here a summary of what is known.

1. Proposition 7.3.1 says that if $\mathcal{O}_{\alpha,\beta,\gamma} \leq \mathcal{O}_{\lambda,\epsilon,\mu}$ then $(\alpha, \beta, \gamma) \leq (\lambda, \epsilon, \mu)$.
2. Conjecture 7.3.4 is true if $n = 1$, and the inequalities in 7.3.2 are a natural generalization of the inequalities given in [1].
3. Theorem 6.4.13 shows that R_f is intimately related to the closure order.

4. Propositions 7.4.1 and 7.5.4 give two important cases in which the conjecture definitely holds. In fact, we used proposition 7.4.1 when we proved that ‘ \leq ’ defines a partial order on the set of striped n -bipartitions.
5. The condition $(\alpha, \beta, \gamma) \leq (\lambda, \epsilon, \mu)$ gives us an effective way to compute all *candidate* closure relations. Meanwhile, propositions 7.4.1, 7.5.4, and 8.2.3 give simple criteria that we can use to construct many closure relations. So, we can construct the closure relations determined by these propositions and the partial order ‘ \leq ’ to compare them.

A computer search has been conducted on all cases where $\dim V \leq 12$. This produced 4,190,717 orbits and 730,048,342 closure relations. Among the closure relations predicted by ‘ \leq ’ only 70 are not explained by these propositions; each of these was subsequently hand-verified using proposition 7.1.3.

While this evidence does not give a complete proof of the conjecture, it suggests that some version of the conjecture is true and that a proof is possible. So, the obvious extension of this work is to either complete the proof of conjecture 7.3.4 or to refine it to a correct statement that can be proved.

Another direction that this work can be taken is suggested by the work of Kato. The resolution of singularities π constructed in 7.1 may contain representation-theoretic data. Specifically, Kato’s construction hints at a possibility that the fibers of this map may index representations of a Weyl group of type B.

In connection with this, we discussed in section 1.2 that if $n = 2$ then $K = GL(p) \times GL(q)$ is the complexification of a maximal compact subgroup of $U(p, q)$. It is known that K acts on the flag variety G/B with finitely many orbits, with $K \backslash G/B$ parametrized by involutions in S_{p+q} with signed fixed points. There is an associated “moment” map $K \backslash G/B \rightarrow K \backslash \mathcal{N}$. From a combinatorial standpoint, this map can be computed by an algorithm of Garfinkel.

The author has constructed an “enhanced” flag variety $V_0 \times (G/B)$ and parametrized the set $K \backslash (V_0 \times (G/B))$ of orbits. It is expected that there is a similar “enhanced moment map” $K \backslash (V_0 \times (G/B)) \rightarrow K \backslash (\tilde{V} \times \mathcal{N})$ and one might hope to describe it with a Garfinkel-type combinatorial algorithm.

REFERENCES

- [1] P. N. ACHAR AND A. HENDERSON, *Orbit closures in the enhanced nilpotent cone*, Adv. Math., 219 (2008), pp. 27–62.
- [2] D. H. COLLINGWOOD AND W. M. MCGOVERN, *Nilpotent orbits in semisimple Lie algebras*, Van Nostrand Reinhold Mathematics Series, Van Nostrand Reinhold Co., New York, 1993.
- [3] A. HENDERSON, *Fourier transform, parabolic induction, and nilpotent orbits*, Transform. Groups, 6 (2001), pp. 353–370.
- [4] S. KATO, *An exotic springer correspondence for symplectic groups*, 2006.
- [5] S. KATO, *An exotic Deligne-Langlands correspondence for symplectic groups*, Duke Math. J., 148 (2009), pp. 305–371.
- [6] G. KEMPKEN, *Eine Darstellung des Köchers \tilde{A}_k* , Bonner Mathematische Schriften [Bonn Mathematical Publications], 137, Universität Bonn Mathematisches Institut, Bonn, 1982. Dissertation, Rheinische Friedrich-Wilhelms-Universität, Bonn, 1981.
- [7] R. TRAVKIN, *Mirabolic Robinson-Schensted-Knuth correspondence*, Selecta Math. (N.S.), 14 (2009), pp. 727–758.