

Sample Quiz 6

Sample Quiz 6, Problem 1. Vertical Motion Seismoscope

The 1875 **horizontal motion seismoscope** of F. Cecchi (1822-1887) reacted to an earthquake. It started a clock, and then it started motion of a recording surface, which ran at a speed of 1 cm per second for 20 seconds. The clock provided the observer with the earthquake hit time.

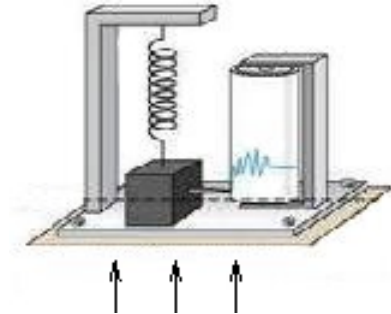

A Simplistic Vertical Motion Seismoscope

The apparently stationary heavy mass on a spring writes with the attached stylus onto a rotating drum, as the ground moves up. The generated trace is $x(t)$.

The motion of the heavy mass m in the figure can be modeled initially by a forced spring-mass system with damping. The initial model has the form

$$mx'' + cx' + kx = f(t)$$

where $f(t)$ is the vertical ground force due to the earthquake. In terms of the vertical ground motion $u(t)$, we write via Newton's second law the force equation $f(t) = -mu''(t)$ (compare to falling body $-mg$). The final model for the motion of the mass is then

$$\begin{cases} x''(t) + 2\beta\Omega_0 x'(t) + \Omega_0^2 x(t) = -u''(t), \\ \frac{c}{m} = 2\beta\Omega_0, \quad \frac{k}{m} = \Omega_0^2, \\ x(t) = \text{center of mass position measured from equilibrium,} \\ u(t) = \text{vertical ground motion due to the earthquake.} \end{cases} \quad (1)$$

Terms **seismoscope**, **seismograph**, **seismometer** refer to the device in the figure. Some observations:

Slow ground movement means $x' \approx 0$ and $x'' \approx 0$, then (1) implies $\Omega_0^2 x(t) = -u''(t)$. The seismometer records ground acceleration.

Fast ground movement means $x \approx 0$ and $x' \approx 0$, then (1) implies $x''(t) = -u''(t)$. The seismometer records ground displacement.

A **release test** begins by starting a vibration with u identically zero. Two successive maxima $(t_1, x_1), (t_2, x_2)$ are recorded. This experiment determines constants β, Ω_0 .

The objective of (1) is to determine $u(t)$, by knowing $x(t)$ from the seismograph.

The Problem.

(a) Explain how a **release test** can find values for β, Ω_0 in the model $x'' + 2\beta\Omega_0 x' + \Omega_0^2 x = 0$.

(b) Assume the seismograph trace can be modeled at time $t = 0$ (a time after the earthquake struck) by $x(t) = Ce^{-at} \sin(bt)$ for some positive constants C, a, b . Assume a release test determined $2\beta\Omega_0 = 12$ and $\Omega_0^2 = 100$. Explain how to find a formula for the ground motion $u(t)$, then provide a formula for $u(t)$, using technology.

Solution.

(a) A **release test** is an experiment which provides initial data $x(0) > 0$, $x'(0) = 0$ to the seismoscope mass. The model is $x'' + 2\beta\Omega_0x' + \Omega_0^2x = 0$ (ground motion zero). The recorder graphs $x(t)$ during the experiment, until two successive maxima $(t_1, x_1), (t_2, x_2)$ appear in the graph. This is enough information to find values for β, Ω_0 .

In an under-damped oscillation, the characteristic equation is $(r + p)^2 + \omega^2 = 0$ corresponding to complex conjugate roots $-p \pm \omega i$. The phase-amplitude form is $x(t) = Ce^{-pt} \cos(\omega t - \alpha)$, with period $2\pi/\omega$.

The equation $x'' + 2\beta\Omega_0x' + \Omega_0^2x = 0$ has characteristic equation $(r + \beta)^2 + \Omega_0^2 = 0$. Therefore $x(t) = Ce^{-\beta t} \cos(\Omega_0 t - \alpha)$.

The period is $t_2 - t_1 = 2\pi/\Omega_0$. Therefore, Ω_0 is known. The maxima occur when the cosine factor is 1, therefore

$$\frac{x_2}{x_1} = \frac{Ce^{-\beta t_2} \cdot 1}{Ce^{-\beta t_1} \cdot 1} = e^{-\beta(t_2 - t_1)}.$$

This equation determines β .

(b) The equation $-u''(t) = x''(t) + 2\beta\Omega_0x'(t) + \Omega_0^2x(t)$ (the model written backwards) determines $u(t)$ in terms of $x(t)$. If $x(t)$ is known, then this is a quadrature equation for the ground motion $u(t)$.

For the example $x(t) = Ce^{-at} \sin(bt)$, $2\beta\Omega_0 = 12$, $\Omega_0^2 = 100$, then the quadrature equation is

$$-u''(t) = x''(t) + 12x'(t) + 100x(t).$$

After substitution of $x(t)$, the equation becomes

$$-u''(t) = Ce^{-at} (\sin(bt) a^2 - \sin(bt) b^2 - 2 \cos(bt) ab - 12 \sin(bt) a + 12 \cos(bt) b + 100 \sin(bt))$$

which can be integrated twice using Maple, for simplicity. All integration constants will be assumed zero. The answer:

$$u(t) = \frac{Ce^{-at} (12 a^2 b + 12 b^3 - 200 ab) \cos(bt)}{(a^2 + b^2)^2} - \frac{Ce^{-at} (a^4 + 2 a^2 b^2 + b^4 - 12 a^3 - 12 ab^2 + 100 a^2 - 100 b^2) \sin(bt)}{(a^2 + b^2)^2}$$

The Maple session has this brief input:

```
de:=-diff(u(t),t,t) = diff(x(t),t,t) + 12*diff(x(t),t) + 100* x(t);
x:=t->C*exp(-a*t)*sin(b*t);
dsolve(de,u(t));subs(_C1=0,_C2=0,%);
```

Sample Quiz6 Problem 2. Resistive Network with 2 Loops and DC Sources.

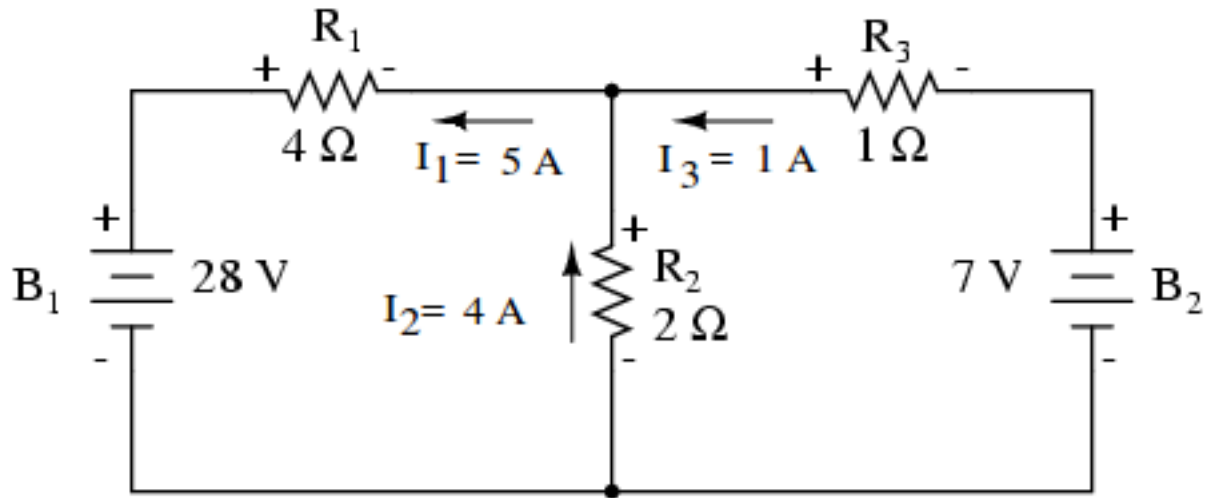

The **Branch Current Method** can be used to find a 3×3 linear system for the **branch currents** I_1, I_2, I_3 .

$$\begin{array}{rcll} I_1 - I_2 - I_3 & = & 0 & \text{KCL, upper node} \\ 4I_1 + 2I_2 & = & 28 & \text{KVL, left loop} \\ 2I_2 - I_3 & = & 7 & \text{KVL, right loop} \end{array}$$

Symbol **KCL** means *Kirchhoff's Current Law*, which says the algebraic sum of the currents at a node is zero. Symbol **KVL** means *Kirchhoff's Voltage Law*, which says the algebraic sum of the voltage drops around a closed loop is zero.

(a) Solve the equations to verify the currents reported in the figure: $I_1 = 5, I_2 = 4, I_3 = 1$ Amperes.

(b) Compute the voltage drops across resistors R_1, R_2, R_3 . Answer: 20, 8, 1 volts.

References. Edwards-Penney 3.7, electric circuits. All About Circuits Volume I – DC, by T. Kuphaldt:

<http://www.allaboutcircuits.com/>.

Course slides on Electric Circuits:

<http://www.math.utah.edu/~gustafso/s2014/2250/electricalCircuits.pdf>.

Solved examples of electrical networks can be found in the lecture notes of Ruye Wang:

<http://fourier.eng.hmc.edu/e84/lectures/ch2/node2.html>.

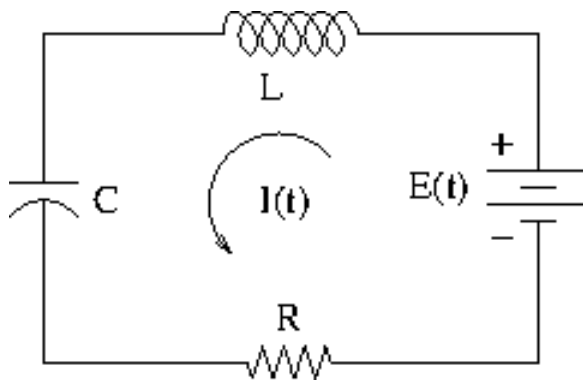
Sample Quiz 6, Problem 3. RLC-Circuit

The Problem. Suppose $E = 100 \sin(20t)$, $L = 5$ H, $R = 250 \Omega$ and $C = 0.002$ F. The model for the charge $Q(t)$ is $LQ'' + RQ' + \frac{1}{C}Q = E(t)$.

- (a) Differentiate the charge model and substitute $I = \frac{dQ}{dt}$ to obtain the current model $5I'' + 250I' + 500I = 2000 \cos(20t)$.
- (b) Find the **reactance** $S = \omega L - \frac{1}{\omega C}$, where $\omega = 20$ is the input frequency, the natural frequency of $E = 100 \sin(20t)$ and $E' = 2000 \cos(20t)$.
- (c) Substitute $I = A \cos(20t) + B \sin(20t)$ into the current model (a) and solve for $A = \frac{-12}{109}$, $B = \frac{40}{109}$. Then the steady-state current is

$$I(t) = A \cos(20t) + B \sin(20t) = \frac{-12 \cos(20t) + 40 \sin(20t)}{109}.$$

- (d) Write the answer in (c) in phase-amplitude form $I = I_0 \sin(20t - \delta)$ with $I_0 > 0$ and $\delta \geq 0$. Then compute the **time lag** δ/ω .

Answers: $I_0 = \frac{4}{\sqrt{109}}$, $\delta = \arctan(3/10)$, $\delta/\omega = 0.01457$.

References

Course slides on Electric Circuits:

<http://www.math.utah.edu/~gustafso/s2015/2280/electricalCircuits.pdf>.

Edwards-Penney *Differential Equations and Boundary Value Problems*, sections 3.4, 3.5, 3.6, 3.7.

Solutions to Problem 3

Problem 1(a) Start with $5Q'' + 250Q' + 500Q = 100 \sin(20t)$. Differentiate across to get $5Q''' + 250Q'' + 500Q' = 2000 \cos(20t)$. Change Q' to I .

Problem 1(b) $S = (20)(5) - 1/(20 * 0.002) = 75$

Problem 1(c) It helps to use the differential equation $u'' + 400u = 0$ satisfied by both $u_1 = \cos(20t)$ and $u_2 = \sin(20t)$. Functions u_1, u_2 are Euler solution atoms, hence independent. Along the solution path, we'll use $u'_1 = -20 \sin(20t) = -20u_2$ and $u'_2 = 20 \cos(20t) = 20u_1$. The arithmetic is simplified by dividing the equation first by 5. We then substitute $I = Au_1 + Bu_2$.

$$\begin{aligned} I'' + 50I' + 100I &= 400 \sin(20t) \\ A(u''_1 + 50u'_1 + 100u_1) + B(u''_2 + 50u'_2 + 100u_2) &= 400 \sin(20t) \\ A(-400u_1 + 50(-20u_2) + 100u_1) + B(-400u_2 + 50(20u_1) + 100u_2) &= 400 \sin(20t) \\ (-400A + 100A + 1000B)u_1 + (-1000A - 400B + 100B)u_2 &= 400u_2 \end{aligned}$$

By independence of u_1, u_2 , coefficients of u_1, u_2 on each side of the equation must match. The linear algebra property is called *unique representation of linear combinations*. This implies the 2×2 system of equations

$$\begin{aligned} -300A + 1000B &= 0, \\ -1000A - 300B &= 400. \end{aligned}$$

The solution by Cramer's rule (the easiest method) is $A = -12/109, B = 40/109$. Then the steady-state current is

$$I(t) = A \cos(20t) + B \sin(20t) = \frac{-12 \cos(20t) + 40 \sin(20t)}{109}.$$

The **steady-state current** is defined to be the sum of those terms in the general solution of the differential equation that remain after all terms that limit to zero at $t = \infty$ have been removed. The logic is that only these terms contribute to a graphic or to a numerical calculation after enough time has passed (as $t \rightarrow \infty$).

Problem 1(d) Let $\cos(\delta) = B/I_0, \sin(\delta) = -A/I_0, I_0 = \sqrt{A^2 + B^2}$. Use the trig identity

$$\sin(a - b) = \sin(a) \cos(b) - \cos(a) \sin(b)$$

to rearrange the current formula as follows:

$$I(t) = A \cos(20t) + B \sin(20t) = I_0(\sin(20t) \cos(\delta) - \sin(\delta) \cos(20t)) = I_0 \sin(20t - \delta).$$

Compute $I_0 = \sqrt{A^2 + B^2} = \frac{4}{\sqrt{109}}$. Compute $\tan(\delta) = \frac{\sin \delta}{\cos \delta} = -A/B = 12/40$. Then $\delta = \arctan(12/40)$ and finally $\delta/\omega = \arctan(3/10)/20 = 0.01457$.

Another method, using Edwards-Penney Section 3.7: Compute the **impedance** $Z = \sqrt{R^2 + S^2} = \sqrt{250^2 + 75^2} = \sqrt{68125} = 25\sqrt{109}$ and then $I_0 = E_0/Z = 4/\sqrt{109}$. The phase $\delta = \arctan(S/R) = \arctan(75/250) = \arctan(3/10)$. Then the time lag is $\delta/\omega = \frac{\arctan(0.3)}{20} = 0.01457$.
