

Contents

| | | |
|-----------|--|------------|
| 1 | Introduction to Hi-Fi | 1 |
| 2 | Waves | 14 |
| 3 | Decibels | 63 |
| 4 | Loudspeakers | 67 |
| 5 | Electricity | 112 |
| 6 | Amplifiers | 138 |
| 7 | Electromagnetism | 153 |
| 8 | Electromagnetic Waves and Tuners | 173 |
| 9 | Analog Recording and Playback | 202 |
| 10 | Digital Optical Recording & Playback | 226 |
| 11 | Digital Magnetic Recording & Playback | 247 |
| 12 | Heat | 260 |
| 13 | Mechanics | 273 |

List of Figures

| | | |
|------|---|----|
| 1.1 | Stereo process in recording and playback. | 2 |
| 1.2 | Surround sound reproduction of audio information. | 3 |
| 1.3 | Storage or transmission of sound in stereo. | 3 |
| 1.4 | Playback process in stereo. | 4 |
| 1.5 | Elements of a receiver. | 4 |
| 1.6 | Example of basic connections to a receiver. | 5 |
| 1.7 | Elements of an integrated amplifier. | 5 |
| 1.8 | Connections to an integrated amplifier. | 6 |
| 1.9 | All separate approach. | 6 |
| 1.10 | Connections in all-separate approach. | 7 |
| 1.11 | Basic A/V System. | 8 |
| 1.12 | A/V receiver driving a surround-sound system. | 9 |
| 1.13 | Details of the tape monitor switch when listening to a sound source with available tape recording. | 10 |
| 1.14 | Listening to a tape; tape switch in. | 11 |
| 1.15 | A/V receiver with Dolby Pro Logic processor. | 12 |
| 1.16 | Various wave forms. | 13 |
| 2.1 | Phono record and an enlarged groove showing engraved wave representing sound. | 15 |
| 2.2 | Simplified picture of a water wave; displaced water as a func- tion of position. | 15 |
| 2.3 | Details of one wave as a function of position. | 16 |
| 2.4 | Large and small amplitude waves. | 16 |
| 2.5 | Time dependence of displacement of a point on a water wave. | 17 |
| 2.6 | Displacement as a function of time; time required to complete one wave. | 17 |
| 2.7 | Transverse wave on a string. | 18 |
| 2.8 | Longitudinal waves along a solid bar. | 18 |

| | | |
|------|---|----|
| 2.9 | Addition of two waves. | 18 |
| 2.10 | Sound requires a medium in which to propagate; in a vacuum there is no sound propagation. | 19 |
| 2.11 | Direct radiator speaker can move air like a drumhead. | 19 |
| 2.12 | Generation of sound by loudspeaker. | 20 |
| 2.13 | Disturbances created by loudspeaker; pressure changes cause sound. | 21 |
| 2.14 | Representation of sound created by a loudspeaker. | 21 |
| 2.15 | Wave Y has 4 times the power of wave X , but their amplitudes differ only by a factor of 2. | 22 |
| 2.16 | Reflection of a wave by an obstacle or a different medium. | 22 |
| 2.17 | Speaker producing a pulse of sound in a hall. | 23 |
| 2.18 | Paths of direct and reflected sound in a hall. | 24 |
| 2.19 | Direct and reverberant sound in a hall. | 25 |
| 2.20 | Direct and reverberant sound contributions to sound in a hall. | 26 |
| 2.21 | Sound radiated by a speaker; as one moves away the intensity decreases. | 27 |
| 2.22 | Sound intensity through surface 2 is different from that of 1. | 28 |
| 2.23 | Observer and source at rest and in relative motion. | 29 |
| 2.24 | Doppler Effect produced by speaker producing simultaneously 100 Hz and 1,000 Hz sound waves. | 30 |
| 2.25 | Sound wave in cold air entering hot air. | 31 |
| 2.26 | Refraction of a sound wave. | 31 |
| 2.27 | Above a critical angle of incidence there is only reflection. | 32 |
| 2.28 | Sound travels in a curved hollow plastic tube by multiple reflections. | 33 |
| 2.29 | Sound wave produced by a musical group; a complex wave. | 34 |
| 2.30 | Simple sine waveform. | 34 |
| 2.31 | Comparison between one full wave and one rotation of a circle. | 35 |
| 2.32 | Addition of two waves. | 35 |
| 2.33 | Addition of two waves out of phase by 180 degrees. | 35 |
| 2.34 | Constructive interference. | 36 |
| 2.35 | Destructive interference. | 37 |
| 2.36 | Obstacle with aperture receiving high frequency waves. | 38 |
| 2.37 | Low frequency behavior of obstacle and aperture. | 39 |
| 2.38 | Comparison of diffraction behavior of a room with opening and a loudspeaker. | 40 |
| 2.39 | Dispersion characteristics of a speaker. | 41 |
| 2.40 | Standing wave produced by incident and reflected waves. | 41 |

| | | |
|------|---|----|
| 2.41 | Simplest possible standing wave on a string. | 42 |
| 2.42 | Simplest standing wave on a string during one cycle. | 43 |
| 2.43 | Second harmonic on a string showing position of nodes and antinodes. | 43 |
| 2.44 | Third harmonic on a string clamped at both ends. | 43 |
| 2.45 | Setting up a standing wave in a tube. | 44 |
| 2.46 | Simplest standing wave in a tube open at both ends. | 45 |
| 2.47 | Second harmonic in tube open at both ends. | 45 |
| 2.48 | Fundamental in a tube. | 45 |
| 2.49 | Tube open at one end excited by a tuning fork. | 46 |
| 2.50 | Fundamental in tube open at one end. | 46 |
| 2.51 | Next more complicated standing wave; the third harmonic. | 47 |
| 2.52 | Fifth harmonic. | 47 |
| 2.53 | Standing wave in a tube 1 meter long; fundamental. | 47 |
| 2.54 | Tube closed at both ends. | 48 |
| 2.55 | Fundamental of a tube closed at both ends. | 48 |
| 2.56 | Room where independent standing waves can be set up in the x, y, and z directions. | 49 |
| 2.57 | A drumhead fixed at its edges and its fundamental mode of vibration. | 50 |
| 2.58 | Overtone on a drumhead. | 51 |
| 2.59 | Standing wave pattern on a Chladni plate. | 51 |
| 2.60 | Complex wave created by the superposition of a 100 Hz fun- damental and its fourth harmonic. | 52 |
| 2.61 | Violin string plucked by a finger and producing all sorts of harmonics. | 53 |
| 2.62 | Complex wave generated by plucking string. | 54 |
| 2.63 | Square wave; it is made up of many harmonics. | 55 |
| 2.64 | Spectrum of a square wave. | 56 |
| 2.65 | Sawtooth wave and its harmonic content. | 57 |
| 2.66 | Spectrum of a sawtooth wave. | 58 |
| 2.67 | A string bowed at its middle and harmonics which are excited. | 59 |
| 2.68 | String on a piano struck by hammer at a distance 1/10 the string length from one end. | 60 |
| 2.69 | Vibrations of an object at different excitation frequencies. | 60 |
| 2.70 | Oscillations of a mass on a spring, undamped and damped when submersed in oil. | 61 |
| 2.71 | Resonance of wine glass excited by sound. | 61 |

| | | |
|------|--|----|
| 2.72 | Beats caused by the combination of two waves with slightly different frequencies. | 62 |
| 3.1 | Decibel meter. | 64 |
| 3.2 | Receiver with volume control marked in dB. | 64 |
| 3.3 | Response of human ears at the threshold of hearing. | 64 |
| 3.4 | Response of human ears for various sound levels: Fletcher-Munson curves. | 65 |
| 3.5 | Outer ear approximated by a tube closed at one end. | 65 |
| 3.6 | Measuring the frequency response of a speaker. | 66 |
| 3.7 | Frequency response of a speaker. | 66 |
| 4.1 | Role of loudspeaker. | 68 |
| 4.2 | Distortion of spectrum of original waveform by non-flat frequency response of speaker. | 69 |
| 4.3 | Dispersion properties of speakers. | 70 |
| 4.4 | Two low frequency waves from speaker arriving at O. | 71 |
| 4.5 | Two high frequency waves from speaker arriving at O. | 72 |
| 4.6 | Details of waves 2 and 1 at high frequencies. | 73 |
| 4.7 | Sound dispersion of a driver as the frequency is increased. | 74 |
| 4.8 | Division of audio spectrum for a three-way loudspeaker. | 75 |
| 4.9 | Net effect of subdividing the whole audio range into three sections. | 76 |
| 4.10 | Subdivision of audio spectrum in a two-way system. | 76 |
| 4.11 | Amount of sound produced depends on volume displacement. A is louder than B. | 77 |
| 4.12 | To produce same amount of sound by both drivers at the same frequency, the small one has to move through a larger distance than the big one. | 78 |
| 4.13 | Volume of air moved by loudspeaker as a function of frequency to produce same loudness of sound. | 79 |
| 4.14 | Low frequency and high frequency simple pendulums doing different amounts of work per second for same amplitude of displacement. | 80 |
| 4.15 | Balance between electrical power going to driver and the production of sound power and heat dissipation by driver. | 80 |
| 4.16 | Example of a loudspeaker whose efficiency is less than 100%. | 81 |
| 4.17 | Basic cone speaker. | 82 |

| | | |
|------|--|-----|
| 4.18 | Comparison of cone-shape over flat shape for mechanical strength when thin material is used. | 83 |
| 4.19 | Modeling of diaphragm action by mass-spring oscillating system. | 84 |
| 4.20 | Standing wave on diaphragm of driver. | 85 |
| 4.21 | Standing wave around rim of diaphragm. | 85 |
| 4.22 | Typical frequency response of a cone speaker. | 86 |
| 4.23 | Baffle problem in cone driver. | 86 |
| 4.24 | Front and rear of cone speakers are 180° out of phase. | 87 |
| 4.25 | Baffle action. | 88 |
| 4.26 | Two possible approaches for trapping rear sound in a speaker by means of an enclosure. | 88 |
| 4.27 | Effect of enclosure on frequency response of speaker. | 89 |
| 4.28 | Reducing standing waves inside speaker enclosure. | 90 |
| 4.29 | Basic bass-reflex enclosure. | 91 |
| 4.30 | Oscillating components of bass-reflex speaker. | 92 |
| 4.31 | Splitting of original resonance into two new resonances in bass-reflex system. | 93 |
| 4.32 | Resonant behavior, in-phase and out-of-phase, motion of strongly coupled components of bass-reflex system. | 94 |
| 4.33 | Coupled components of a bass-reflex speaker. | 95 |
| 4.34 | Bass-reflex speaker using a passive radiator over the port. | 96 |
| 4.35 | Helmholtz resonator behaves like mass-spring system. | 97 |
| 4.36 | Bass-reflex speaker using a port or a duct. | 98 |
| 4.37 | Acoustic labyrinth enclosure. | 99 |
| 4.38 | Change of frequency response of speaker when a small enclosure is used. | 100 |
| 4.39 | Effect of small enclosure on frequency response of driver. | 101 |
| 4.40 | Transfer of energy from a bob to one of equal mass, and to one of different mass. | 102 |
| 4.41 | A horn for matching vibrations of a light diaphragm to a large volume of air. | 103 |
| 4.42 | Low frequency response of a horn. | 103 |
| 4.43 | Some common horn shapes. | 104 |
| 4.44 | Folded horn. | 105 |
| 4.45 | Two-way horn loudspeaker with bass-reflex enclosure. | 106 |
| 4.46 | Standing wave set up in a room with maxima and minima in sound pressure. | 107 |

| | | |
|------|---|-----|
| 4.47 | Reflected waves by a wall appear to come from behind the wall since it acts like a mirror. | 107 |
| 4.48 | Stereo coverage in a room. | 108 |
| 4.49 | Speaker phasing: speakers are in phase. | 108 |
| 4.50 | Speaker phasing: speakers are out of phase. | 109 |
| 4.51 | Geometry of a Bose 901 speaker. | 109 |
| 4.52 | Effect of equalizer on frequency response of Bose speakers. . . | 110 |
| 4.53 | Bass horn in Klipsch horn speaker. | 111 |
| 4.54 | Graphic equalizer. | 111 |
| 5.1 | Example of an atom: a Helium atom. | 113 |
| 5.2 | Forces between charged objects; like charges repel and unlike charges attract. | 114 |
| 5.3 | Charged ping-pong balls repelling each other. | 115 |
| 5.4 | Electric field produced by a charged object. | 115 |
| 5.5 | Electric field between two charged plates. | 116 |
| 5.6 | Examples of voltage sources: a battery, the output of a receiver. . . | 116 |
| 5.7 | Electrostatic speaker: basic principle and actual speaker. . . . | 117 |
| 5.8 | Simplified version of an electrostatic speaker at equilibrium. . . | 117 |
| 5.9 | Push-pull action by two plates on charged sheet. | 118 |
| 5.10 | An electrostatic speaker. | 118 |
| 5.11 | Some crystals under pressure produce positive and negative charges on surface. | 119 |
| 5.12 | Dimensional changes of a piezoelectric ceramic when a voltage is applied. | 119 |
| 5.13 | Bending action of a double piezoelectric driver. | 120 |
| 5.14 | Pumping action of cone caused by bending of bimorph. . . . | 120 |
| 5.15 | Typical piezo horn. | 121 |
| 5.16 | Wire connected between two charged objects allows charges to be transferred. | 121 |
| 5.17 | Flow of electric current from amplifier to speaker. | 122 |
| 5.18 | Solid with atoms where electrons are tightly bound and which does not conduct electricity under normal circumstances. . . | 122 |
| 5.19 | Motion of one electron in a conductor in the presence of an electric field. Changes of direction are due to scattering. . . . | 123 |
| 5.20 | Temperature dependence of the electrical resistance in a conductor. | 124 |
| 5.21 | Superconductivity at T_c below which the resistance is zero. . . | 124 |

| | | |
|------|---|-----|
| 5.22 | The resistance to current or to water flow increases as the length of a conductor or pipe increases. Resistance of 2 is double that of 1. | 125 |
| 5.23 | By increasing the cross-sectional area of a conductor, resistance to current or water flow decreases. | 125 |
| 5.24 | Resistor with colored bands to specify its resistance value. . . | 126 |
| 5.25 | Pure silicon, silicon doped with arsenic, and silicon doped with gallium. | 126 |
| 5.26 | Example of simple circuit. | 126 |
| 5.27 | Model using water for electric circuit. | 127 |
| 5.28 | Comparison between DC and AC current. | 128 |
| 5.29 | Representation of a sound wave by an AC electrical signal. . | 128 |
| 5.30 | Variable resistance between X and Y. | 129 |
| 5.31 | Fuse to protect speaker. | 129 |
| 5.32 | Two speakers connected in series to one channel of amplifier. | 129 |
| 5.33 | Model of series circuit. | 130 |
| 5.34 | Parallel connection of two speakers to an amplifier. | 130 |
| 5.35 | Model of parallel connections. | 131 |
| 5.36 | Parallel connections of hi-fi components to house electrical outlet. | 131 |
| 5.37 | Response of cone speaker to a force. | 132 |
| 5.38 | Coil used to produce a magnetic field when a current flows through it. It has inductance. | 133 |
| 5.39 | Frequency dependence of impedance associated with inductance. | 134 |
| 5.40 | Charging of a capacitor. | 134 |
| 5.41 | Charging of a capacitor when polarity of voltage source is reversed. | 135 |
| 5.42 | Frequency dependence of impedance due to capacitance. . . . | 135 |
| 5.43 | Inductance in series with woofer prevents high frequencies from reaching it. | 136 |
| 5.44 | Capacitance in series with tweeter. It prevents low frequencies from reaching it. | 136 |
| 5.45 | Capacitance and inductance in series with mid-range speaker to prevent the high and low frequencies from reaching it. . . . | 137 |
| 5.46 | Impedance curve of driver. | 137 |
| 6.1 | Importance of amplifier in hi-fi system. | 139 |
| 6.2 | Basic amplifier. | 139 |

| | | |
|------|---|-----|
| 6.3 | Amplifier command for more current. | 140 |
| 6.4 | Amplifier command for less current. | 140 |
| 6.5 | Semiconductor junction. | 141 |
| 6.6 | Reverse-biased semiconductor junction. | 141 |
| 6.7 | Forward-biased semiconductor junction. | 142 |
| 6.8 | Symbol for diodes and its characteristics. | 142 |
| 6.9 | Rectifier action of a diode when an AC voltage is applied. . . | 142 |
| 6.10 | Diagram of transistor and its circuit symbol for two possibilities. | 143 |
| 6.11 | Amplifier action of transistor in a circuit compared to control of water flow. | 143 |
| 6.12 | Function of an amplifier. | 144 |
| 6.13 | Amplifier integrated on a chip. | 144 |
| 6.14 | Operational amplifier with negative feedback. | 144 |
| 6.15 | Negative feedback corrects fluctuations in gain. | 145 |
| 6.16 | Positive feedback in large hall with a mike and a loudspeaker system driven by mike. | 145 |
| 6.17 | Volume control. | 146 |
| 6.18 | Comparison of potentiometer action with energy of a ball on a ladder. | 146 |
| 6.19 | Bass and Treble controls. | 147 |
| 6.20 | Effect on signal spectrum of Bass and Treble controls. | 148 |
| 6.21 | Action of LOW and HIGH filters with 6 dB/octave attenua- tion, and also with 18 db/octave attenuation. | 148 |
| 6.22 | Harmonic distortion by amplifier. | 149 |
| 6.23 | Non-linear gain of amplifier. | 149 |
| 6.24 | IM distortion in amplifier. | 150 |
| 6.25 | Distortion increases sharply about power rating of amplifier. . | 150 |
| 6.26 | Clipping of waveform by amplifier at high output levels be- yond the rated value. | 151 |
| 6.27 | Effect of noise from amplifier. | 151 |
| 6.28 | Comparing 2 amplifiers with the same specs. Even though their specs are the same, the amplifiers will sound different. . | 152 |
| 6.29 | A-weighted method of measuring noise. | 152 |
| 7.1 | Effect of current in a wire on compasses around it. | 154 |
| 7.2 | Bar magnet has a north pole and a south pole. | 154 |
| 7.3 | Cutting a bar magnet produces shorter magnets each with its own respective north and south poles. | 154 |
| 7.4 | Magnetic dipole is the basic unit of magnetism. | 155 |

| | | |
|------|--|-----|
| 7.5 | Unmagnetized piece of iron. | 155 |
| 7.6 | Alignment of domains in a piece of iron by a bar magnet. Iron becomes magnetized. | 156 |
| 7.7 | Magnetic field around a bar magnet and a wire carrying a current. | 156 |
| 7.8 | Increasing the magnetic field produced by a current in a wire: by forming a loop, and by using many loops. | 157 |
| 7.9 | An electromagnet. | 157 |
| 7.10 | Determination of direction of magnetic field using first left-hand rule. | 158 |
| 7.11 | Rule for determining direction of magnetic field in an electromagnet. | 158 |
| 7.12 | First left-hand rule and how a cone speaker works. | 159 |
| 7.13 | Force on wire carrying a current in a magnetic field. | 159 |
| 7.14 | The second left-hand rule showing direction of force on wire carrying a current in a magnetic field. | 160 |
| 7.15 | Direction of force depends on orientation of current with respect to magnetic field. | 161 |
| 7.16 | A Heil Speaker. | 162 |
| 7.17 | One set of folds in Heil speaker. | 163 |
| 7.18 | Magnetic Planar Speaker. | 164 |
| 7.19 | Forces on diaphragm when current direction is as indicated. | 165 |
| 7.20 | A bar magnet moving into a coil induces an electric current in that coil. | 165 |
| 7.21 | Induced current in coil by moving magnet. | 166 |
| 7.22 | Significance of relative motion between magnet and coil. | 167 |
| 7.23 | Direction of induced current (wrong). | 167 |
| 7.24 | Direction of induced current (correct). | 168 |
| 7.25 | Schematic of a transformer and its circuit symbol. | 169 |
| 7.26 | Step-up transformer. | 170 |
| 7.27 | Step-down transformer. | 170 |
| 7.28 | Schematic of microphone based on Faraday's law of induction. | 171 |
| 7.29 | Exercise 7.14. | 171 |
| 7.30 | Exercise 7.15. | 172 |
| 7.31 | Exercise 7.18. | 172 |
| 8.1 | Electric Field around charged ping-pong ball. | 174 |
| 8.2 | Oscillating charged ball. | 174 |

| | | |
|------|--|-----|
| 8.3 | Generation of electromagnetic waves at two different frequencies. | 175 |
| 8.4 | Spectrum of electromagnetic waves. | 175 |
| 8.5 | Electromagnetic waves are transverse waves with oscillating electric and magnetic fields. | 176 |
| 8.6 | Production of electromagnetic waves by oscillating electrons in antenna. | 176 |
| 8.7 | Generation of electric and magnetic fields by antenna. | 177 |
| 8.8 | Production of electromagnetic waves by antenna. | 177 |
| 8.9 | Some examples of modulation. | 178 |
| 8.10 | Amplitude modulation. | 178 |
| 8.11 | Carrier and audio signals broadcast by two stations. | 179 |
| 8.12 | Spectrum of an AM carrier at frequency f when modulated by audio signal. | 179 |
| 8.13 | Audio frequencies modulating carrier. | 180 |
| 8.14 | Spectrum of frequencies on carrier for audio frequencies up to 5 kHz. | 180 |
| 8.15 | Spectrum of frequencies due to modulation of carrier. | 181 |
| 8.16 | Frequency modulation (FM). | 181 |
| 8.17 | A low frequency and a high frequency audio signal frequency modulating a carrier. | 182 |
| 8.18 | A loud and a quiet audio signal frequency modulating a carrier. | 183 |
| 8.19 | Action of limiter in FM. | 184 |
| 8.20 | Pre-emphasis in FM broadcasting. | 184 |
| 8.21 | Information brought to tuner on carrier. | 185 |
| 8.22 | De-emphasis of audio information to reduce high frequency noise. | 185 |
| 8.23 | Elements of radio communications. | 186 |
| 8.24 | Superheterodyne receiver. | 186 |
| 8.25 | Processing part of AM signal with a simple diode and filters. | 186 |
| 8.26 | Audio information which will modulate carrier in stereo broadcasting. | 187 |
| 8.27 | Alternating current in antenna produces electromagnetic wave. | 188 |
| 8.28 | Electric field around charged antenna wires is similar to that between charged capacitor plates. | 189 |
| 8.29 | Magnetic fields around a wire and antenna with current. | 189 |
| 8.30 | Development of a standing wave on antenna. | 190 |
| 8.31 | Comparison of standing wave on antenna to that of a string. | 191 |

| | | |
|------|---|-----|
| 8.32 | Radiation pattern of electric field around half-wave dipole antenna. | 192 |
| 8.33 | Polar graph representation of radiation pattern around half-wave dipolar antenna. | 192 |
| 8.34 | Basic elements of a grounded vertical antenna. | 193 |
| 8.35 | Quarter-wave antenna. | 193 |
| 8.36 | Total antenna length is made shorter by inserting a coil in series. | 194 |
| 8.37 | When the electric field of radio wave is vertical, the receiving antenna should also be vertical. | 195 |
| 8.38 | Loop antenna detects the magnetic field part of radio wave. | 195 |
| 8.39 | Two common loop antennas. | 196 |
| 8.40 | Vertically polarized radio wave. | 196 |
| 8.41 | Horizontally polarized radio wave. | 197 |
| 8.42 | Broadcasting with circular polarization. | 197 |
| 8.43 | Low frequency ground wave follows curvature of earth. | 198 |
| 8.44 | Direct (line-of-sight) mode of propagation. | 198 |
| 8.45 | Earth's ionosphere layers. | 199 |
| 8.46 | Sky wave world communications. | 199 |
| 8.47 | Two-hop transmission of radio wave using ionosphere. | 200 |
| 8.48 | Communication using a satellite. | 200 |
| 8.49 | Selectivity relates to how well alternate channels are rejected. | 201 |
| 8.50 | Direct and reflected waves from a broadcasting station. | 201 |
| 8.51 | Capture ratio in tuner. | 201 |
| 9.1 | Record with grooves representing mechanically engraved waves. | 203 |
| 9.2 | Phono playback systems. | 204 |
| 9.3 | Stereo with only one stylus. | 205 |
| 9.4 | A stereo moving magnet phono cartridge. | 206 |
| 9.5 | Unmagnetized and magnetized magnetic material. | 206 |
| 9.6 | Magnetic field produced by a coil when current flows through it. | 207 |
| 9.7 | Alignment of domains in a magnetic material. | 208 |
| 9.8 | Behavior of magnetic material in a coil whose current is increased and decreased to zero. | 209 |
| 9.9 | Memory is destroyed by reversed current in coil. | 210 |
| 9.10 | Hysteresis curve of magnetic material. | 211 |
| 9.11 | Groups of magnetic materials. | 212 |
| 9.12 | Side and top views of magnetic tape. | 213 |

| | | |
|-------|--|-----|
| 9.13 | Magnetic particle of gamma – Iron (III) Oxide as used on tapes. | 213 |
| 9.14 | Recording head aligning magnetic domains on tape. | 214 |
| 9.15 | Analog recording on a magnetic tape. | 215 |
| 9.16 | Recorded information on magnetic tape. | 216 |
| 9.17 | Playback head for reading information on a tape. | 216 |
| 9.18 | Playback head reading signals. | 216 |
| 9.19 | Order of heads on a tape deck. | 217 |
| 9.20 | Recording on material with magnetic hysteresis. | 217 |
| 9.21 | Recording a signal on a tape. | 218 |
| 9.22 | Ideal magnetic characteristics for tape — linear behavior. . . | 219 |
| 9.23 | Useful region on hysteresis curve for magnetic recording. . . . | 220 |
| 9.24 | Recording on magnetic tape with bias. | 221 |
| 9.25 | Details of heads for magnetic recording. | 222 |
| 9.26 | Frequency dependence of output from playback head. | 222 |
| 9.27 | Output from playback head as a function of frequency for various gap sizes and tape speeds. | 223 |
| 9.28 | Equalization in playback. | 223 |
| 9.29 | Equalization in recording. | 224 |
| 9.30 | Typical musical spectrum. | 224 |
| 9.31 | Frequency response at different recording levels. | 225 |
| 9.32 | Exercise 9.4. | 225 |
| 10.1 | Sound wave and its analog representation as a voltage. | 227 |
| 10.2 | Grooves on a record representing analog signals. | 228 |
| 10.3 | Distortion of analog signal by dirt stuck between playback head and tape. | 229 |
| 10.4 | Original number 2 and worn out number 2; basic information is not lost when number is worn out. | 229 |
| 10.5 | (a) Analog signal, decimal scale (b) Analog signal, binary scale. | 230 |
| 10.6 | 20 Hz wave will get more samples per wave than a 200 Hz wave. | 230 |
| 10.7 | Aliasing due to inadequate sampling rate. | 231 |
| 10.8 | Audio spectrum and sideband frequencies due to sampling. . . | 232 |
| 10.9 | Sample and hold of a signal for digitizing. | 233 |
| 10.10 | Multiplexing of left and right channels. | 233 |
| 10.11 | Digitizing a signal. | 234 |
| 10.12 | Output of D-A converter. | 234 |
| 10.13 | Output of low-pass filter. | 235 |
| 10.14 | Main features of playback of digital signal. | 235 |
| 10.15 | Details of information on a CD. | 236 |

| | |
|---|-----|
| 10.16 Interference between light beam reflected from pit and from flat. | 237 |
| 10.17 Focusing action of a laser beam by lens. | 237 |
| 10.18 Reduced effect of surface defect on CD. | 238 |
| 10.19 Laser spot focused on disc data. | 239 |
| 10.20 Three-beam detection; one for read-out and two beams for tracking. | 240 |
| 10.21 Randomly polarized beam and plane-polarized beam. | 241 |
| 10.22 Path of laser beam and role of its polarization. | 242 |
| 10.23 Coherent and incoherent beams of light. | 243 |
| 10.24 Semiconductor laser. | 244 |
| 10.25 Effect of 2-times and 4-times oversampling. | 245 |
| 10.26 Shock-proof memory in mini-disc. | 246 |
| 11.1 Magnetic digital signals recorded vertically on a mini disc. . . | 248 |
| 11.2 Recording digital signals on a mini disc. | 248 |
| 11.3 Kerr effect: plane of polarization of light beam rotates upon reflection from a magnetized surface. | 249 |
| 11.4 Read-out of digital information using Kerr effect. Magnetic field direction affects plane of polarization of reflected laser beam. | 249 |
| 11.5 Difference in read-out between pre-recorded and recordable mini-discs. | 250 |
| 11.6 Section of a recordable mini disc. | 251 |
| 11.7 Layered structure of recordable mini disc. | 251 |
| 11.8 Track pattern in DCC tape. | 252 |
| 11.9 The playback head reads only a portion of the recorded track. | 252 |
| 11.10 Threshold of hearing curve. | 252 |
| 11.11 Sounds which will be recorded by PASC and masking of quiet passages. | 253 |
| 11.12 Representation of digital signal on magnetic tape. | 253 |
| 11.13 Helical recording with rotating heads. | 254 |
| 11.14 Tape contact to rotating head. | 255 |
| 11.15 Time compression to reduce wrap angle. | 256 |
| 11.16 Guard band between tracks on analog tape reduces cross-talk. | 257 |
| 11.17 Azimuthal recording. | 257 |
| 11.18 Digital information on magnetic tape recorded longitudinally. | 258 |
| 11.19 Arrangement of signals on a tape. | 259 |
| 11.20 Exercise 11.7. | 259 |

| | | |
|-------|--|-----|
| 12.1 | Sources of heating in hi-fi due to mechanical friction and electrical “friction” | 261 |
| 12.2 | Electrical “friction” causes heating in amplifier components and voice coil. | 262 |
| 12.3 | Two types of thermometers: alcohol expansion thermometer and gas thermometer. | 263 |
| 12.4 | Temperature dependence of electric resistance of a semiconductor. | 264 |
| 12.5 | Basic circuit for resistance thermometer. | 264 |
| 12.6 | Heating of spot on mini-disc for recording. | 265 |
| 12.7 | Heat conduction along a bar between a hot body and a cold one. | 265 |
| 12.8 | Thermal resistance depends on length of heat conductor. | 266 |
| 12.9 | Thermal resistance depends inversely on cross-sectional area of heat conductor. | 267 |
| 12.10 | Transfer of heat in air by convection. | 268 |
| 12.11 | Object at temperature T emits electromagnetic waves. | 268 |
| 12.12 | Thermal expansion of an object when heated. | 269 |
| 12.13 | Bimetallic strip and its behavior when heated or cooled. | 269 |
| 12.14 | Mounting of transistor and diode on heat sink to transfer heat away from devices by heat conduction. | 270 |
| 12.15 | Heat removal by convection and radiation. | 271 |
| 12.16 | Action of circuit-breaker when too hot. | 271 |
| 12.17 | Thermo-magnetic recording on mini-Disc. | 272 |
| 13.1 | Speed of tape past recording head. | 274 |
| 13.2 | Time for a radio wave to go around the Earth at the equator. | 274 |
| 13.3 | Speed of a recorded signal is the same at X and at Y ; their velocities are different. | 275 |
| 13.4 | Force on voice coil giving it a push or a pull depending on direction of current in voice coil. | 276 |
| 13.5 | Force on tape by capstan-pinch roller. | 277 |
| 13.6 | Static friction-force pulling on tape. | 277 |
| 13.7 | Releasing a CD from its case by applying a pressure on the clips with a finger. | 278 |
| 13.8 | Inertia of a tweeter is less than that of a woofer. | 279 |
| 13.9 | Outer ear; ear drum’s inertia limits response at frequencies above 20 kHz. | 280 |

| | | |
|-------|--|-----|
| 13.10 | Adjusted weight in cartridge for helping the stylus to track the groove in phono record. | 280 |
| 13.11 | Force of clamped magnet on a voice coil accelerates diaphragm in loudspeaker. Force of clamped magnet on focus coil accelerates focus lens in CD player. | 281 |
| 13.12 | Reflection of a pulse on a string clamped at wall and its inversion. | 282 |
| 13.13 | Force on voice coil and force on magnet. | 283 |
| 13.14 | Waves recorded on a phono record and a CD. | 284 |
| 13.15 | Distances covered along outer track and inner track on a phono record. | 285 |
| 13.16 | Frequency of rotation of a CD is made higher near the inner edge and lower near the outer edge to maintain constant linear speed on a tracks. | 286 |
| 13.17 | Rotation of drum head relative to magnetic tape in DAT. . . | 286 |
| 13.18 | When same force is applied to the CD case lid, it is easier to open the lid near the edge because torque is larger there. . . | 287 |
| 13.19 | For the same force exerted on lid, the torque is larger in B than in A. | 288 |
| 13.20 | Moment of inertia of a CD is larger than that of a mini-Disc. | 288 |

Chapter 1

Introduction to Hi-Fi

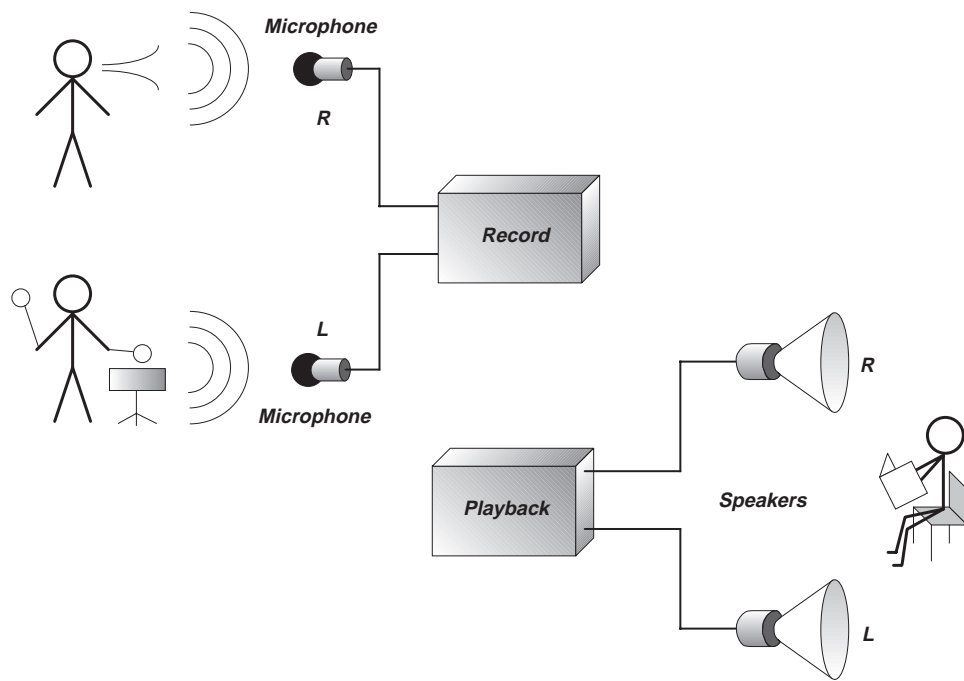

Figure 1.1: Stereo process in recording and playback.

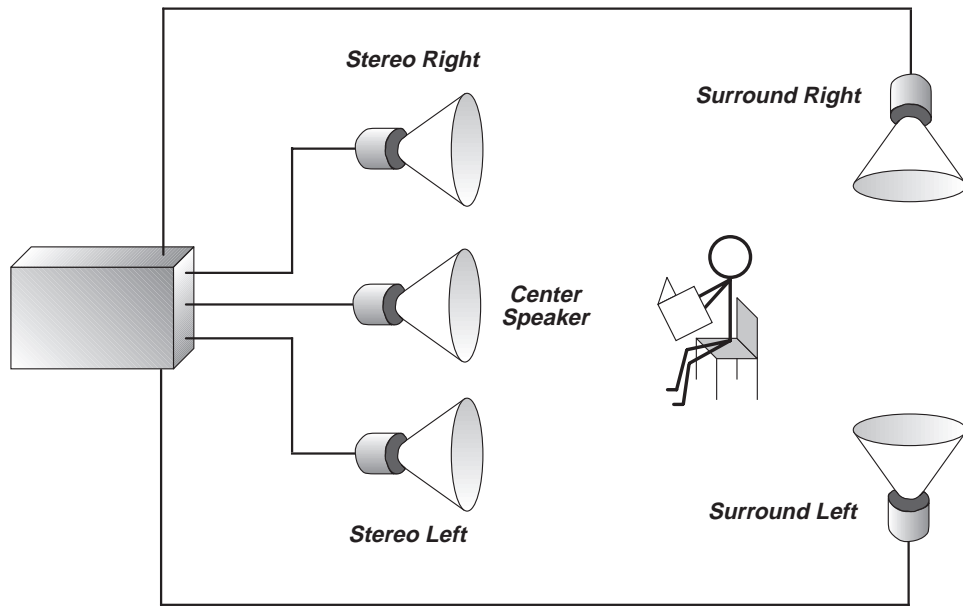

Figure 1.2: Surround sound reproduction of audio information.

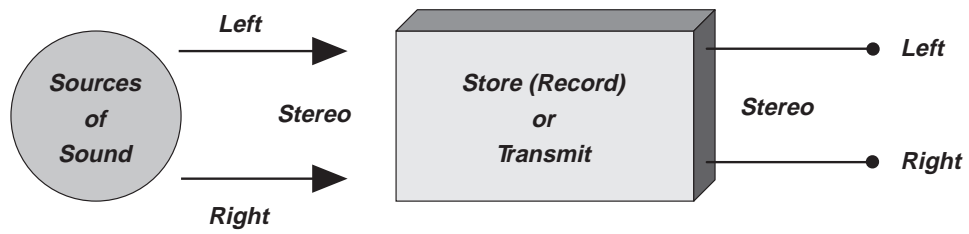

Figure 1.3: Storage or transmission of sound in stereo.

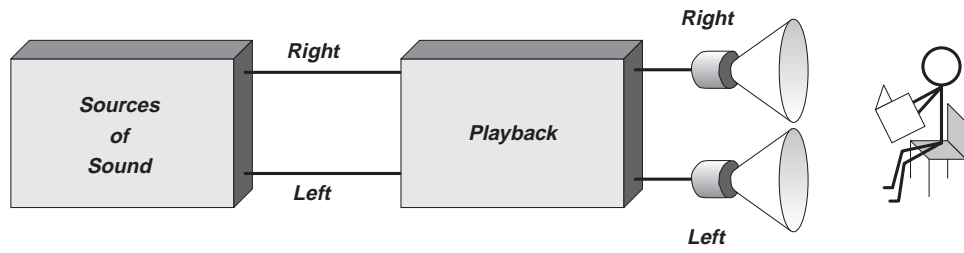

Figure 1.4: Playback process in stereo.

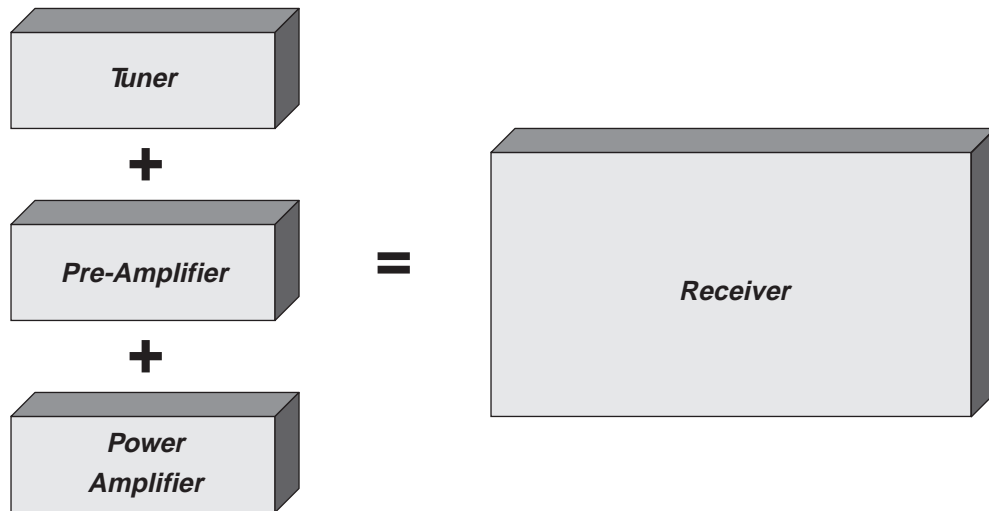

Figure 1.5: Elements of a receiver.

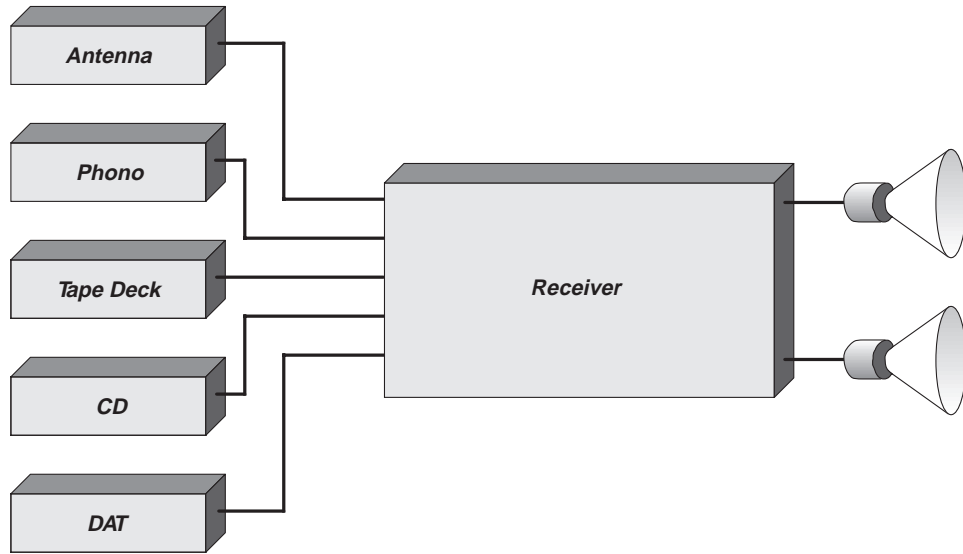

Figure 1.6: Example of basic connections to a receiver.

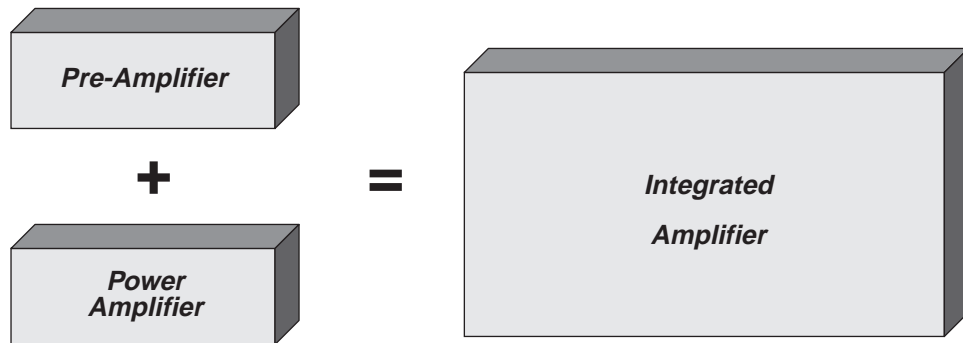

Figure 1.7: Elements of an integrated amplifier.



Figure 1.8: Connections to an integrated amplifier.

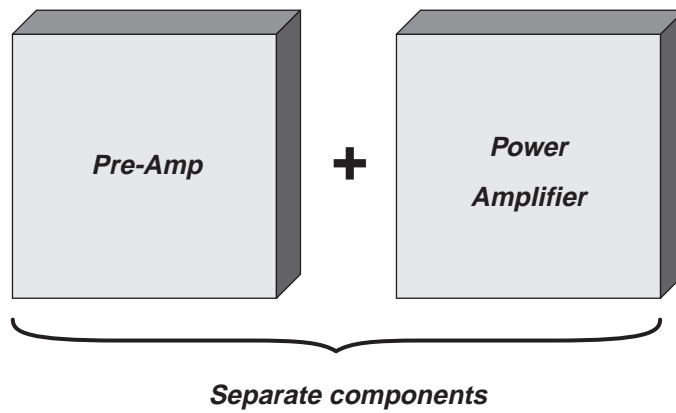

Figure 1.9: All separate approach.

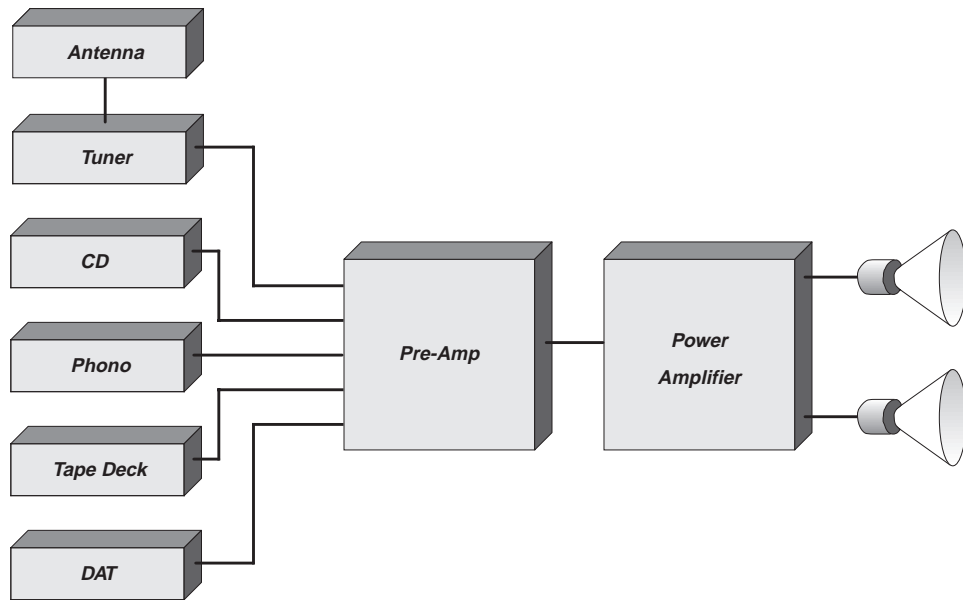

Figure 1.10: Connections in all-separate approach.

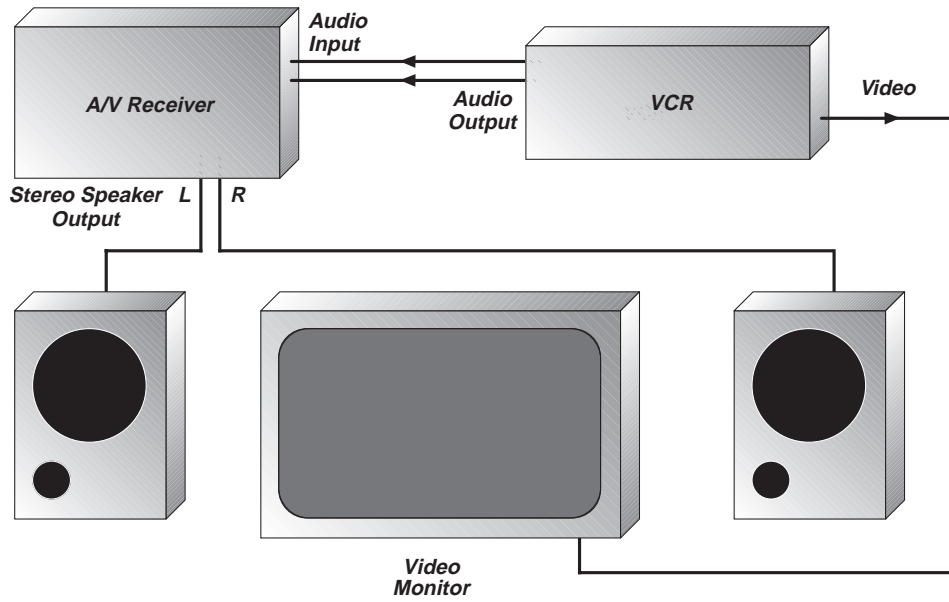

Figure 1.11: Basic A/V System.

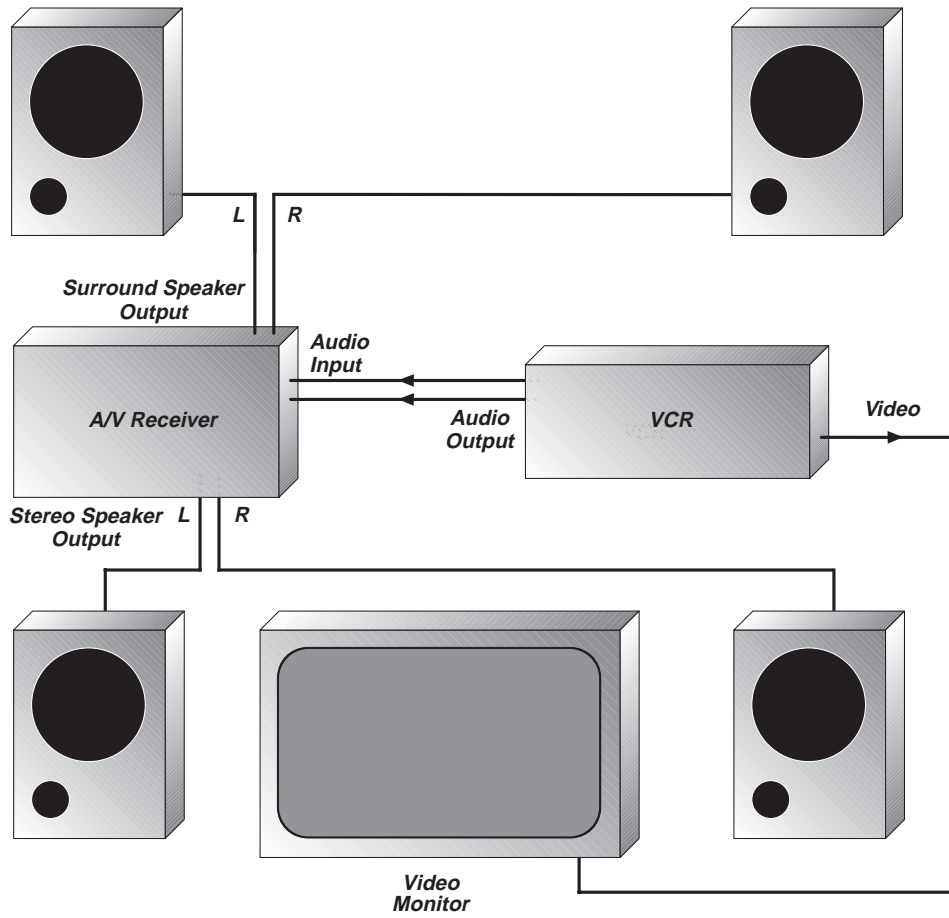

Figure 1.12: A/V receiver driving a surround-sound system.

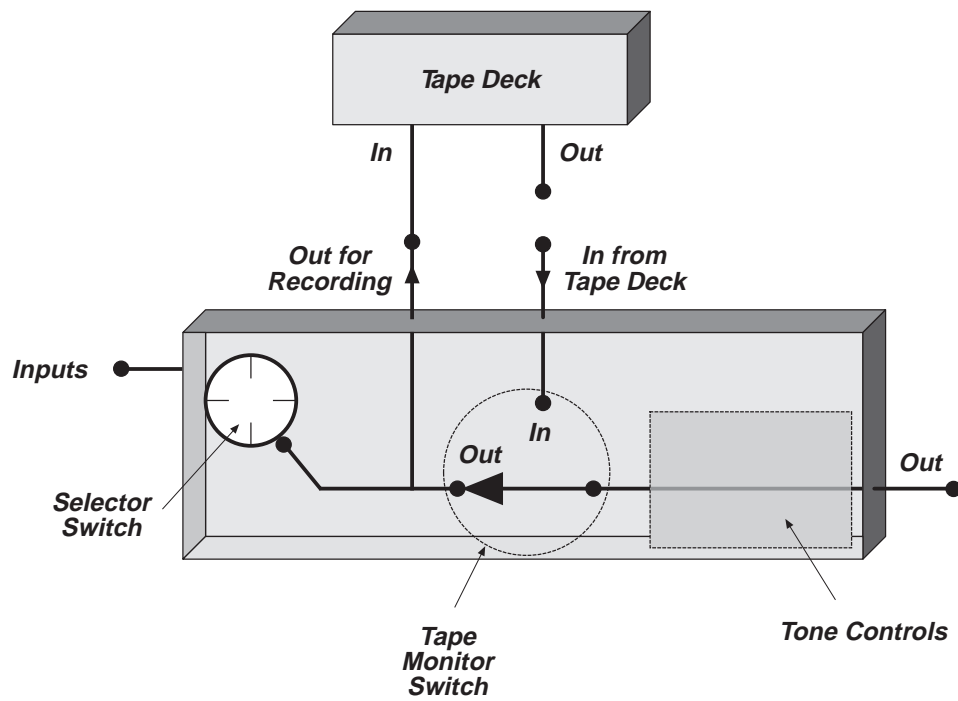

Figure 1.13: Details of the tape monitor switch when listening to a sound source with available tape recording.

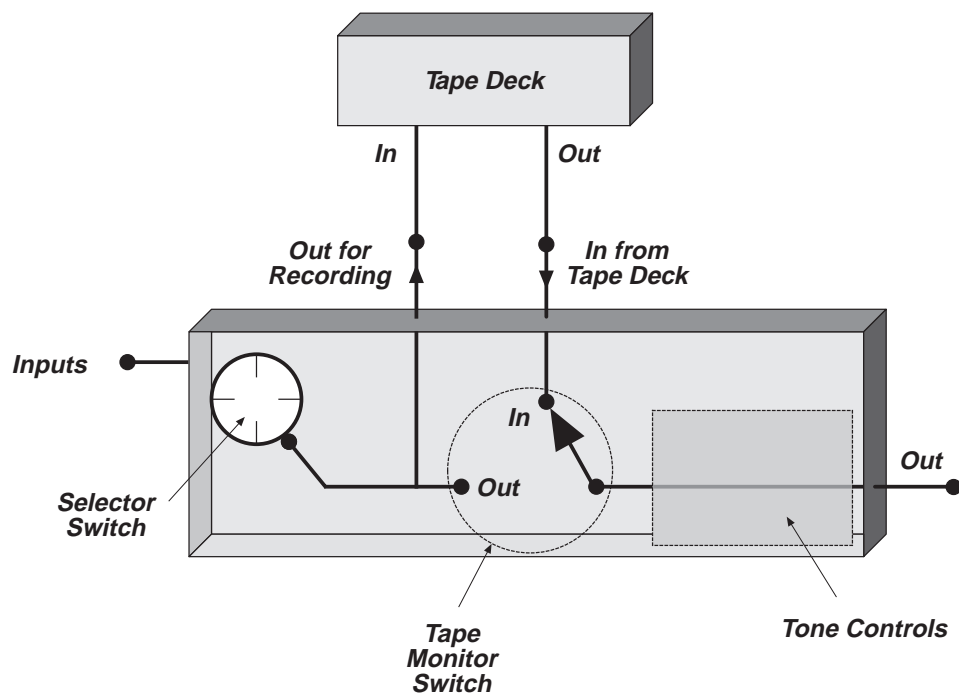

Figure 1.14: Listening to a tape; tape switch in.

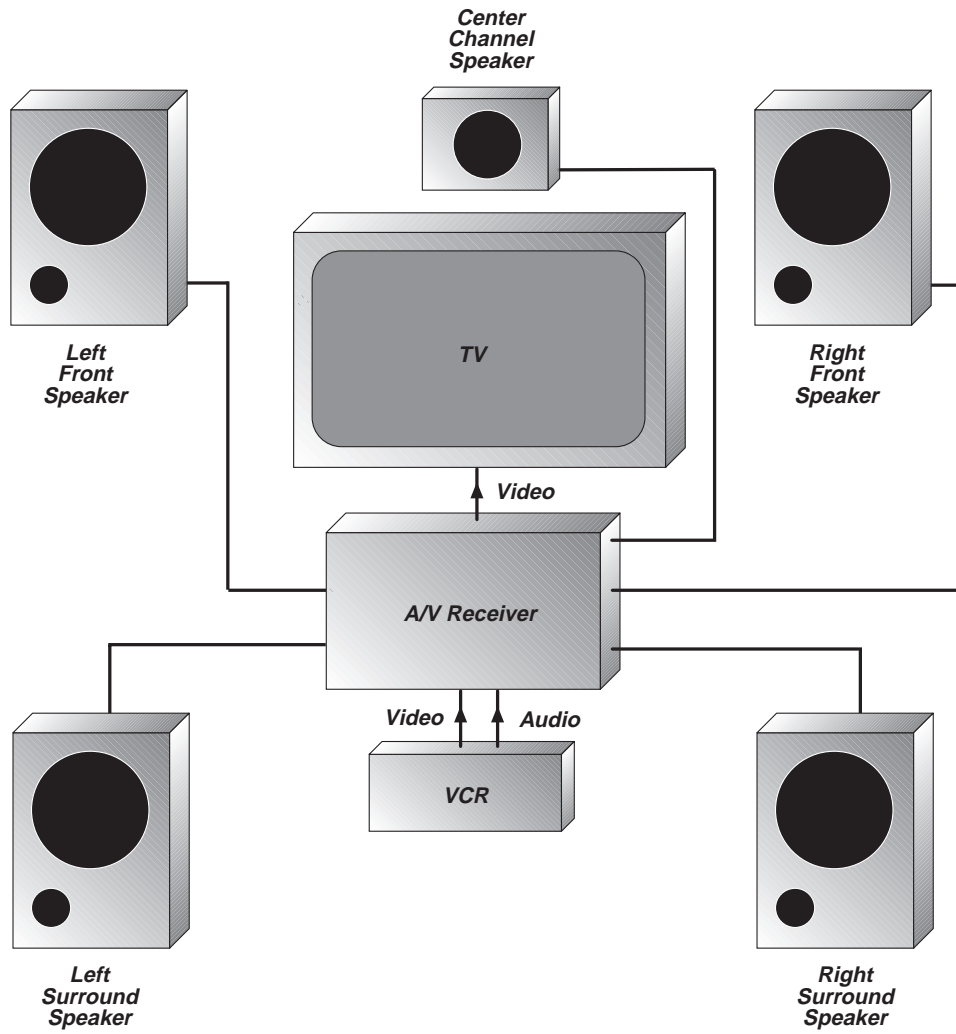

Figure 1.15: A/V receiver with Dolby Pro Logic processor.

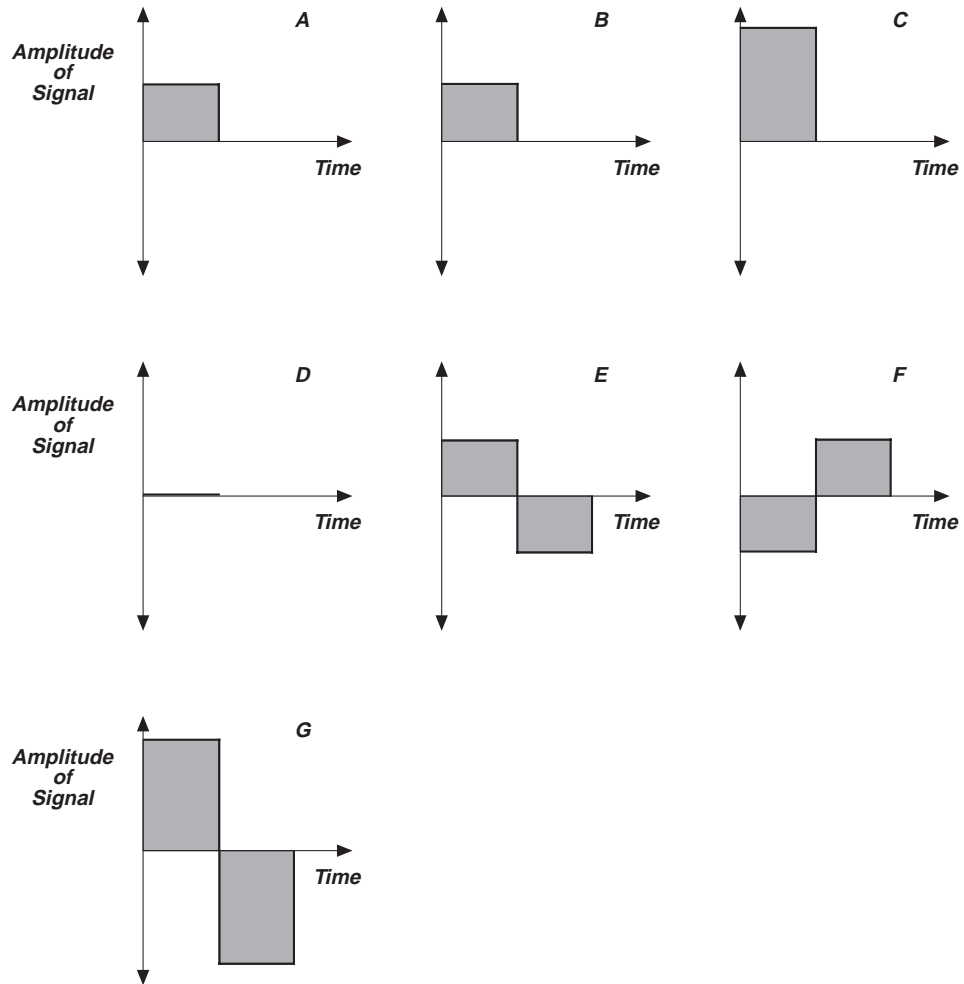

Figure 1.16: Various wave forms.

Chapter 2

Waves

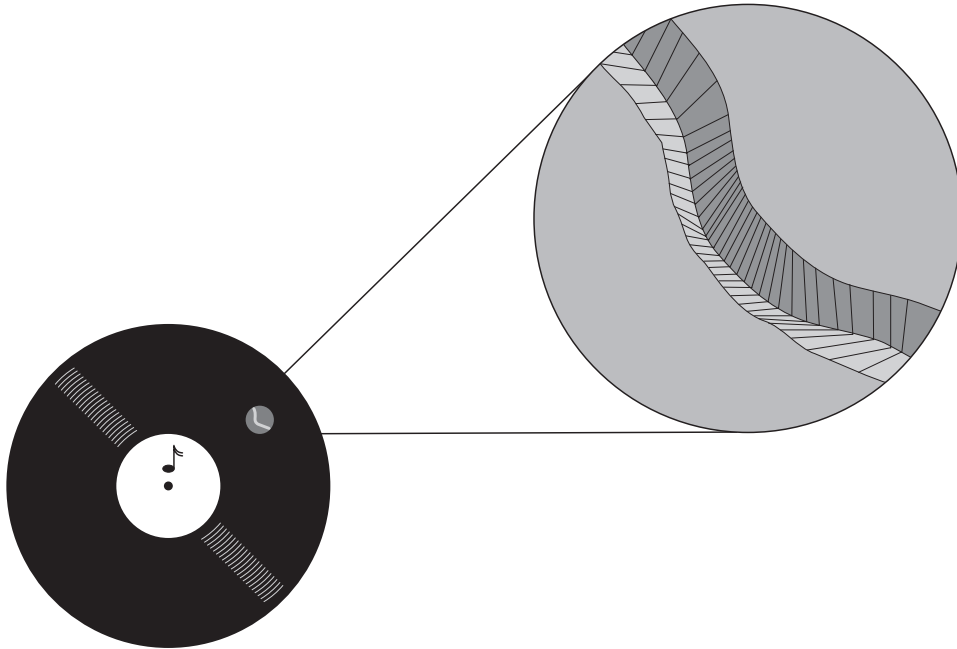

Figure 2.1: Phono record and an enlarged groove showing engraved wave representing sound.

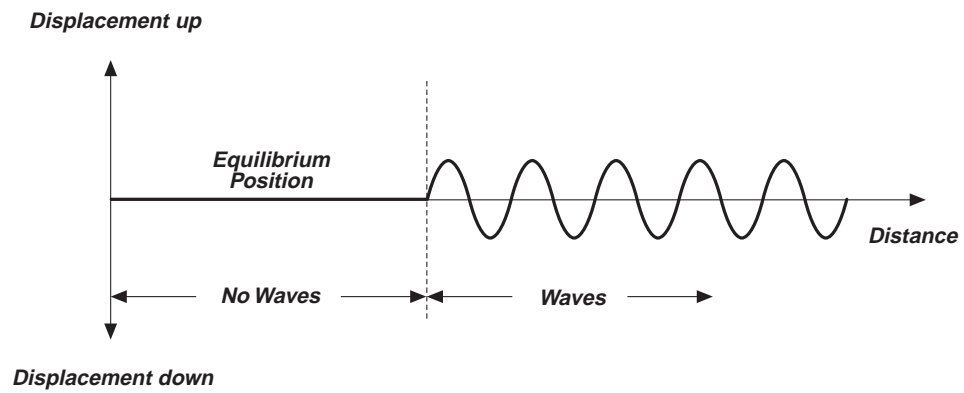

Figure 2.2: Simplified picture of a water wave; displaced water as a function of position.

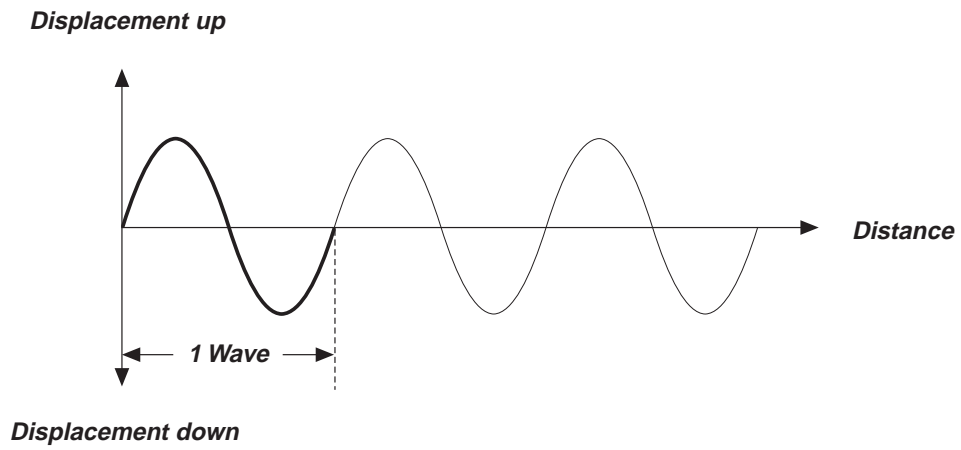

Figure 2.3: Details of one wave as a function of position.

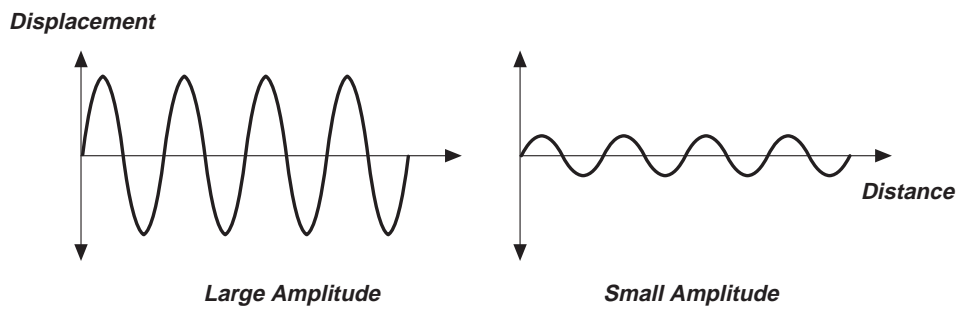

Figure 2.4: Large and small amplitude waves.

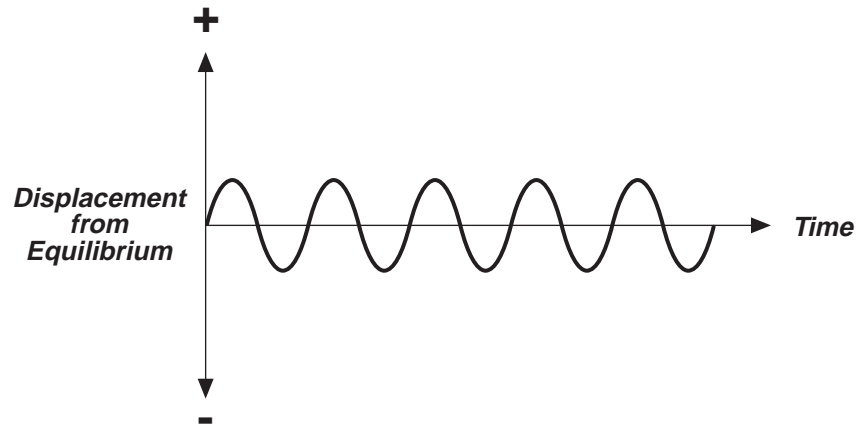

Figure 2.5: Time dependence of displacement of a point on a water wave.

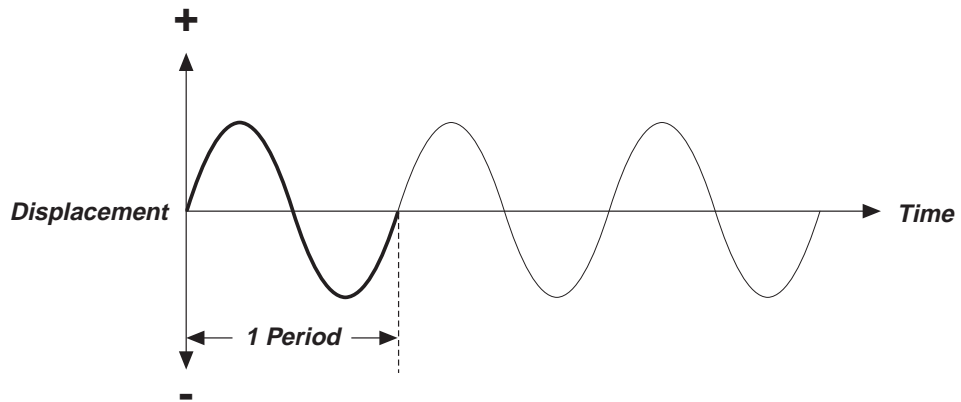

Figure 2.6: Displacement as a function of time; time required to complete one wave.

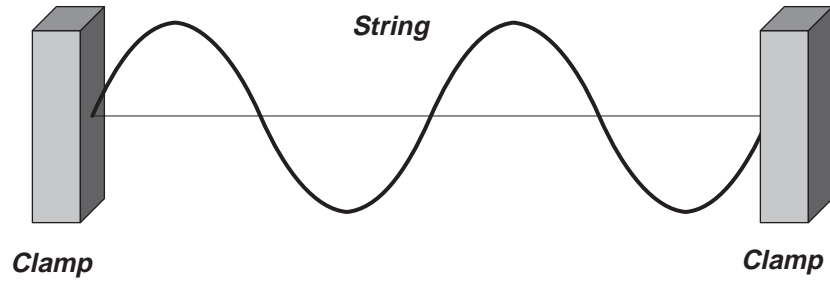

Figure 2.7: Transverse wave on a string.

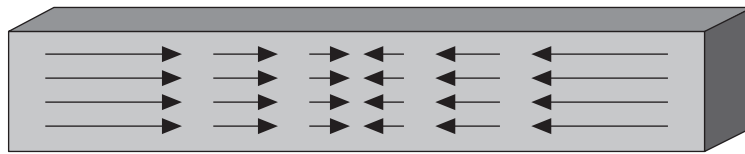

Figure 2.8: Longitudinal waves along a solid bar.

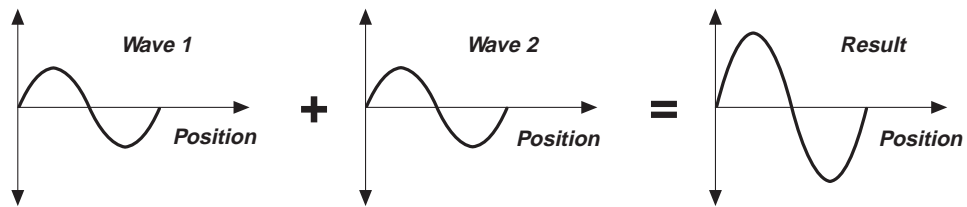

Figure 2.9: Addition of two waves.

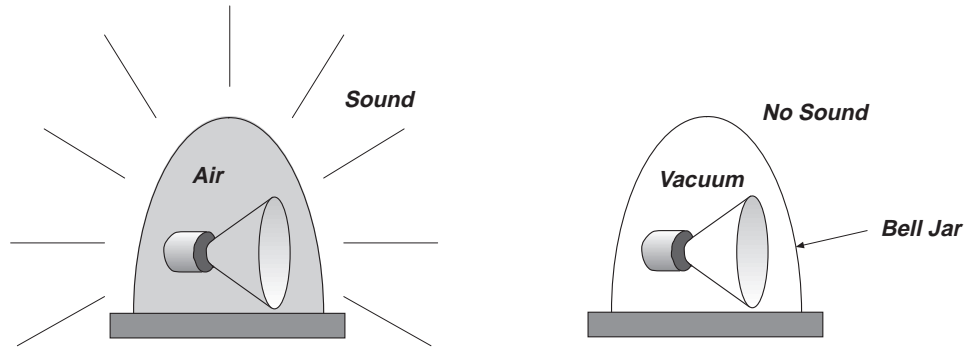

Figure 2.10: Sound requires a medium in which to propagate; in a vacuum there is no sound propagation.

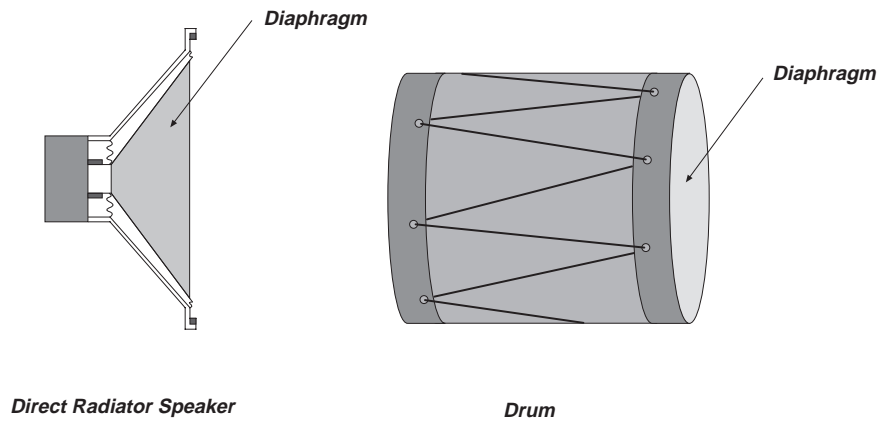

Figure 2.11: Direct radiator speaker can move air like a drumhead.

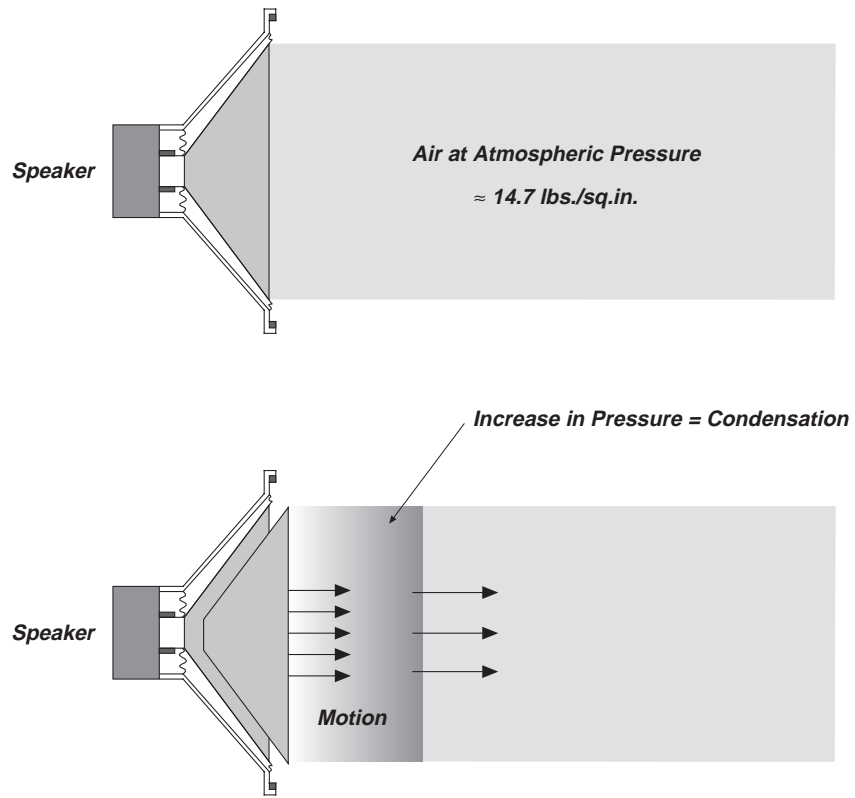

Figure 2.12: Generation of sound by loudspeaker.

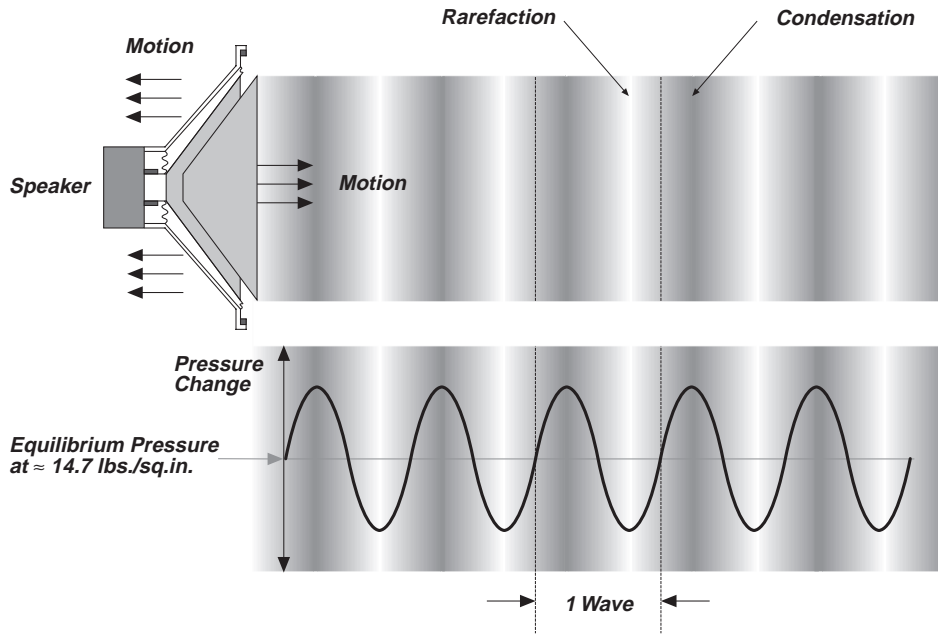

Figure 2.13: Disturbances created by loudspeaker; pressure changes cause sound.

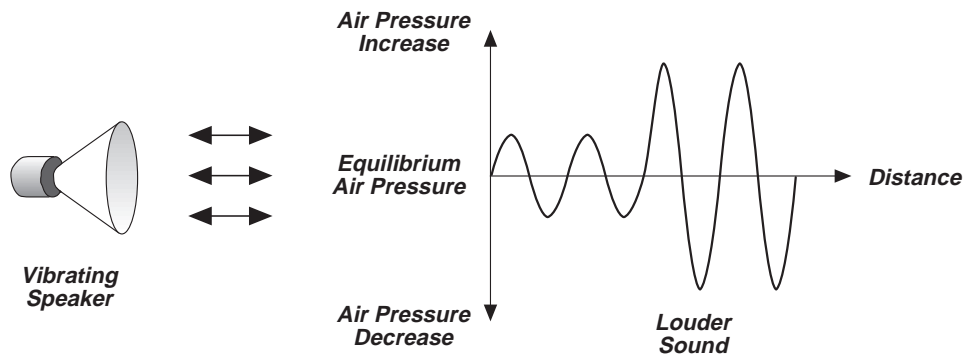

Figure 2.14: Representation of sound created by a loudspeaker.

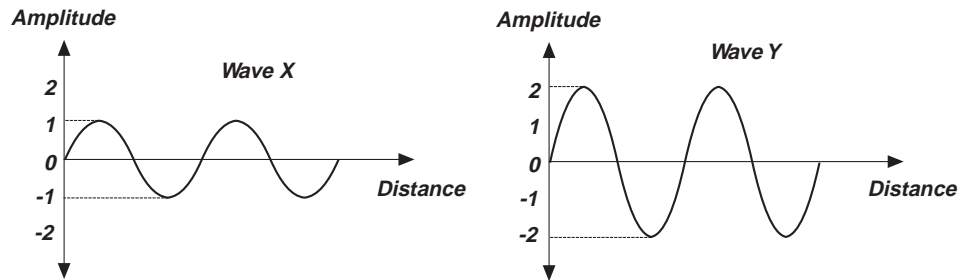

Figure 2.15: Wave **Y** has 4 times the power of wave **X**, but their amplitudes differ only by a factor of 2.

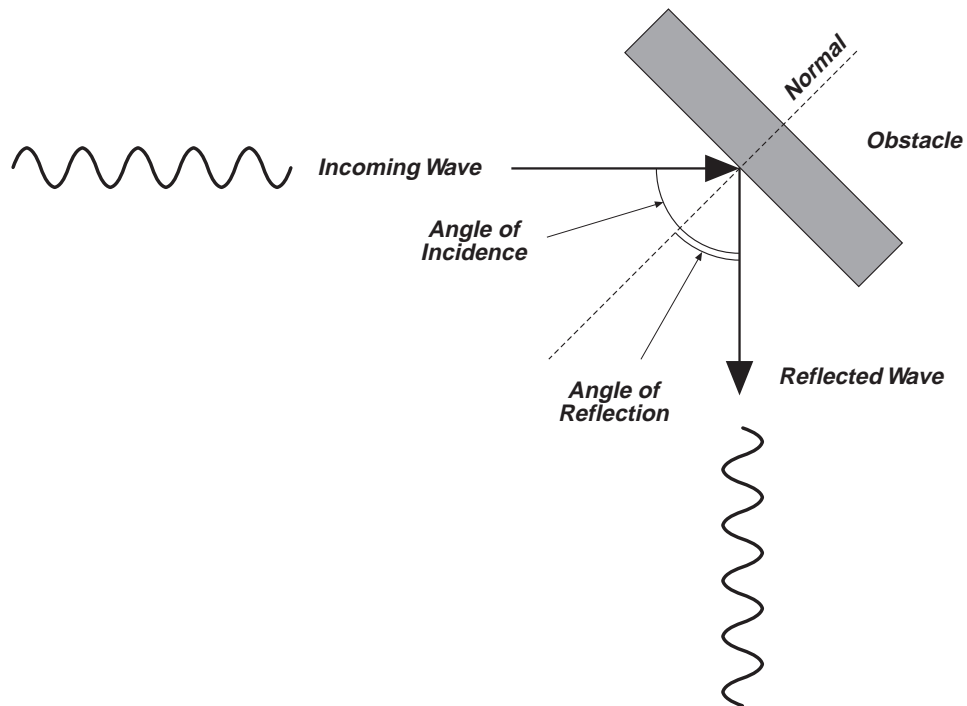

Figure 2.16: Reflection of a wave by an obstacle or a different medium.

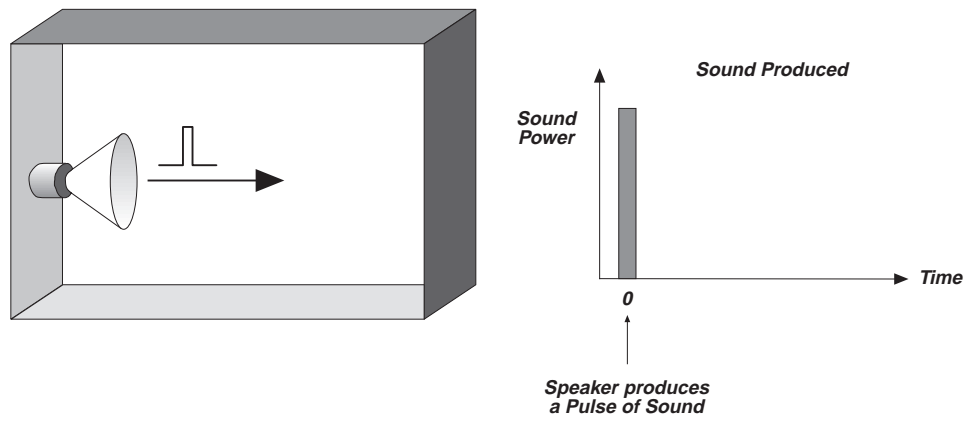

Figure 2.17: Speaker producing a pulse of sound in a hall.

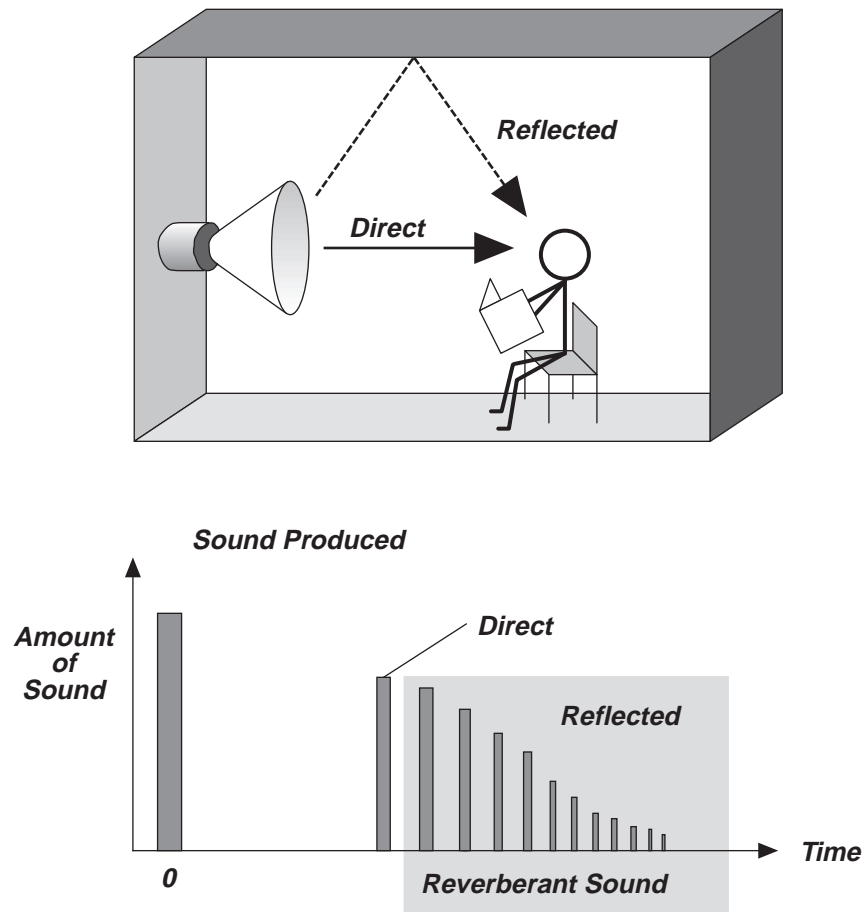

Figure 2.18: Paths of direct and reflected sound in a hall.

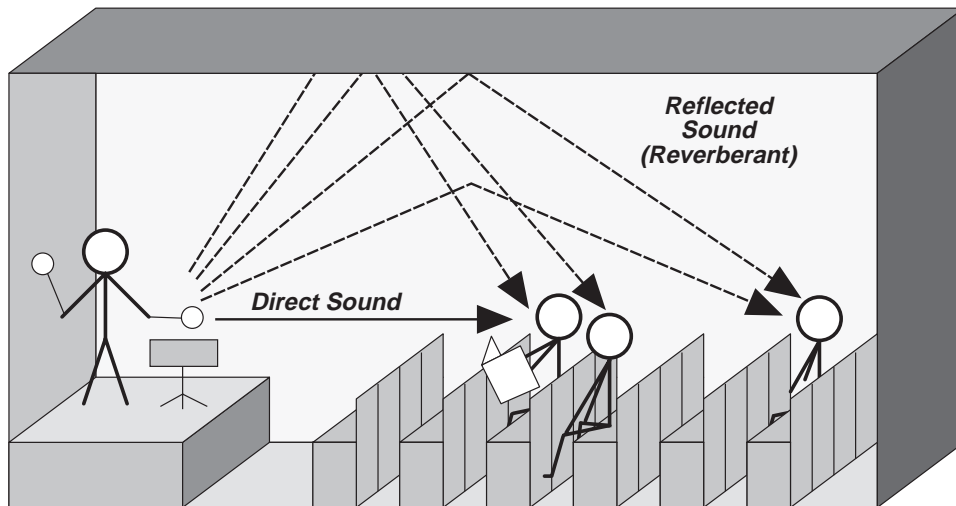

Figure 2.19: Direct and reverberant sound in a hall.

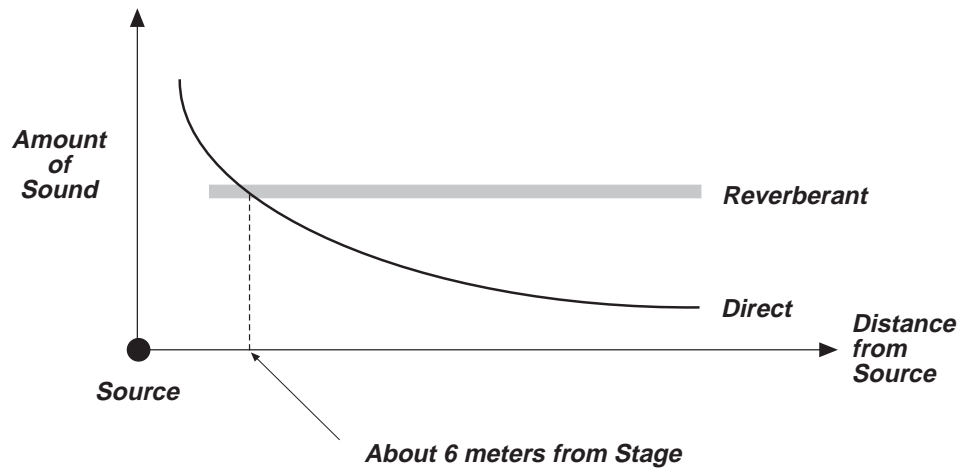

Figure 2.20: Direct and reverberant sound contributions to sound in a hall.

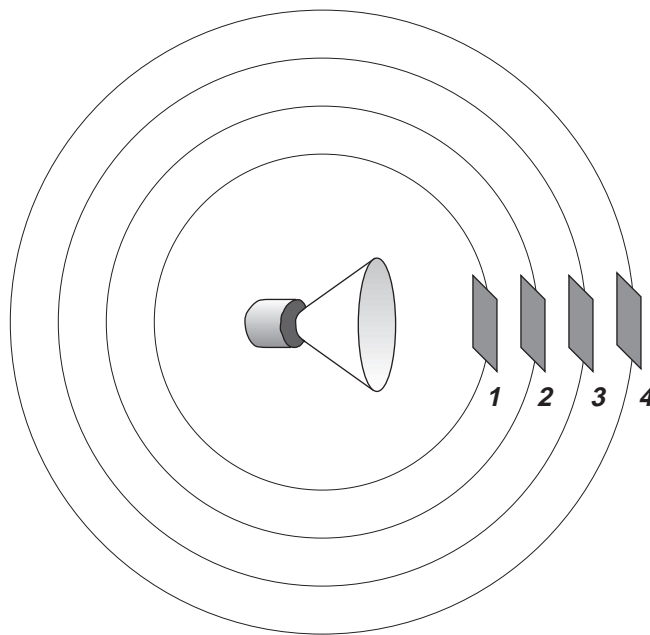

Figure 2.21: Sound radiated by a speaker; as one moves away the intensity decreases.

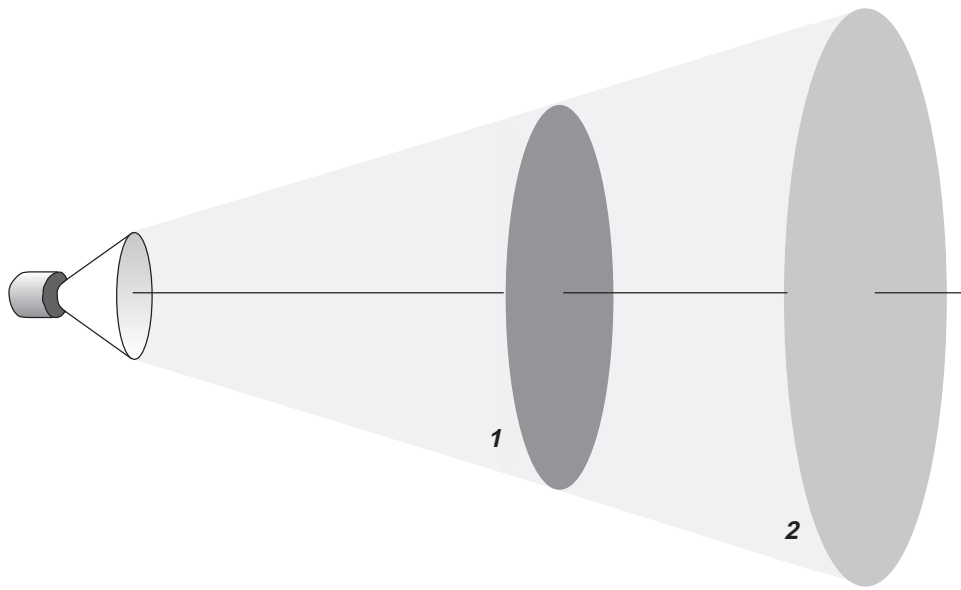

Figure 2.22: Sound intensity through surface 2 is different from that of 1.

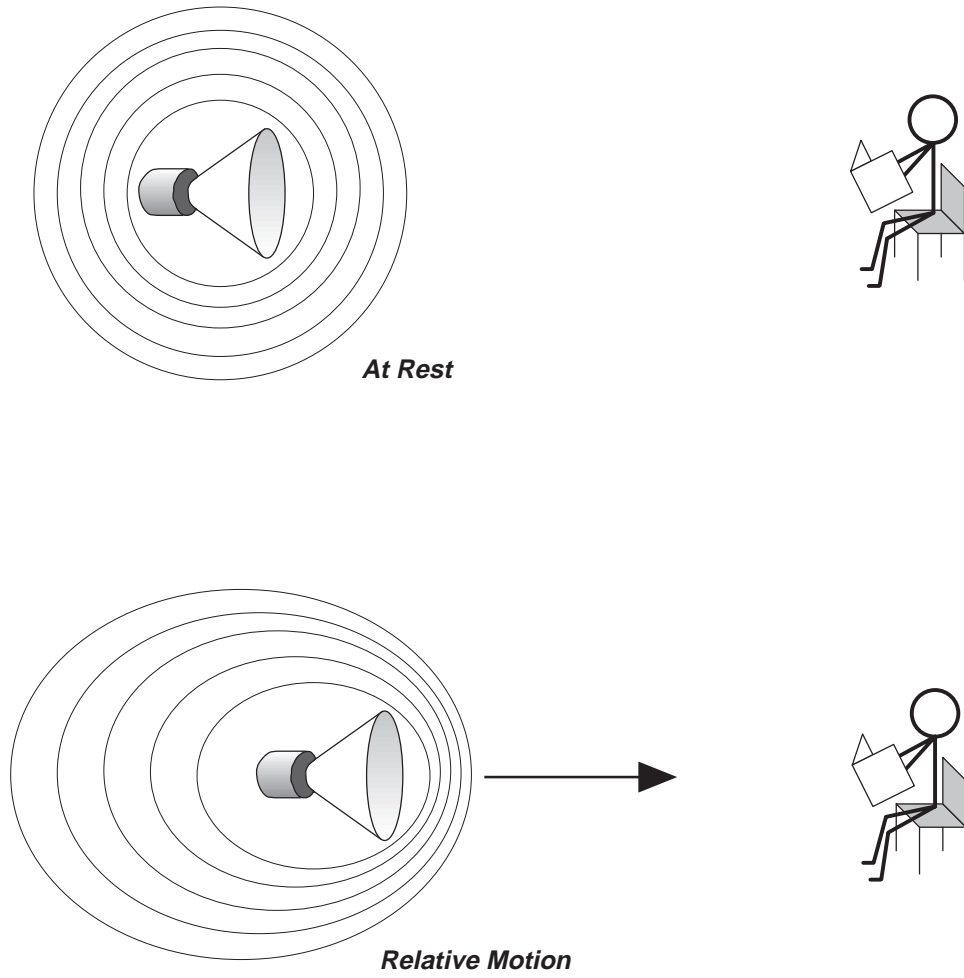

Figure 2.23: Observer and source at rest and in relative motion.

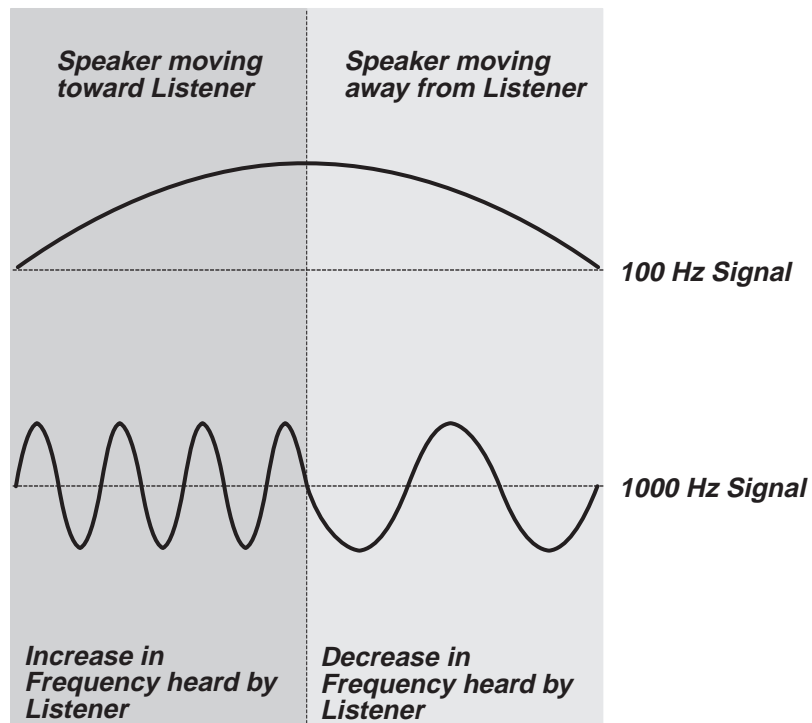

Figure 2.24: Doppler Effect produced by speaker producing simultaneously 100 Hz and 1,000 Hz sound waves.

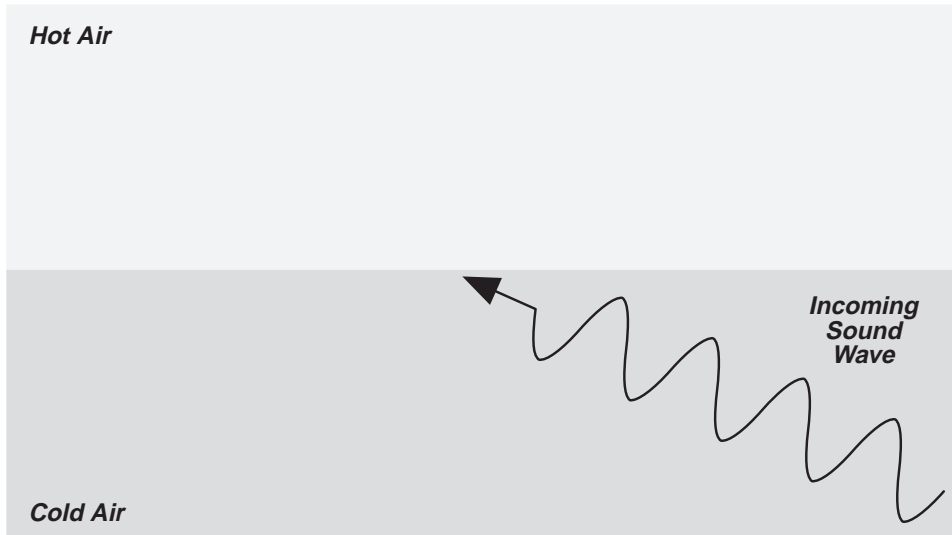

Figure 2.25: Sound wave in cold air entering hot air.

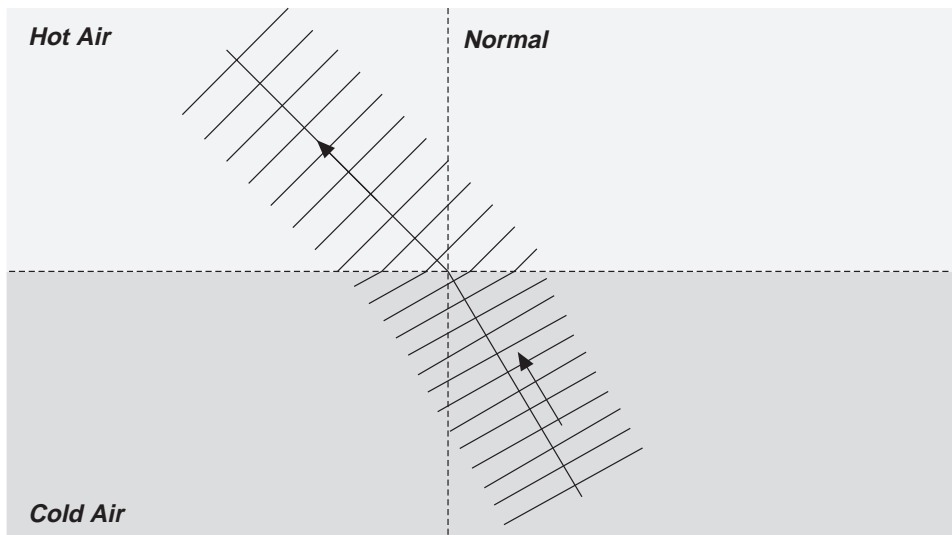

Figure 2.26: Refraction of a sound wave.

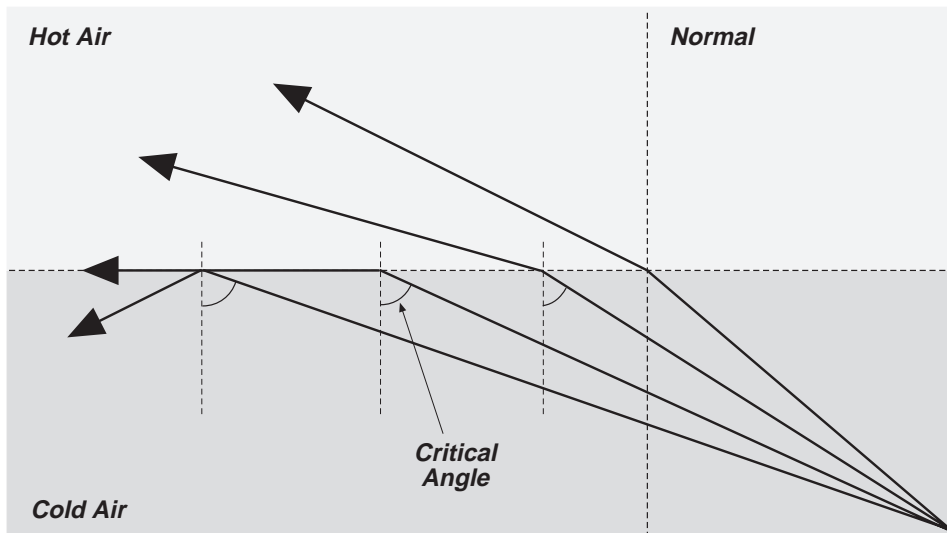

Figure 2.27: Above a critical angle of incidence there is only reflection.

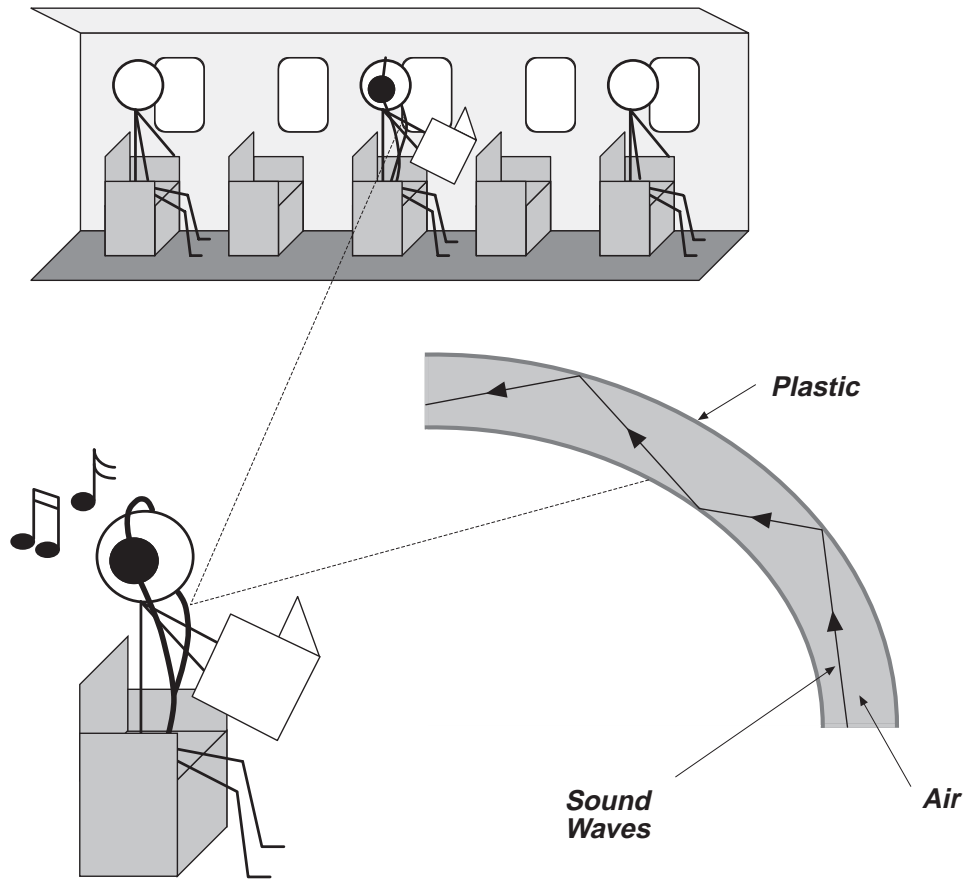

Figure 2.28: Sound travels in a curved hollow plastic tube by multiple reflections.

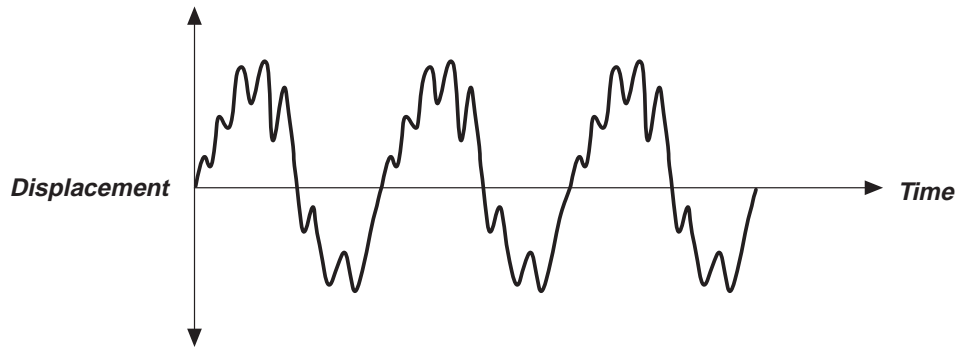

Figure 2.29: Sound wave produced by a musical group; a complex wave.

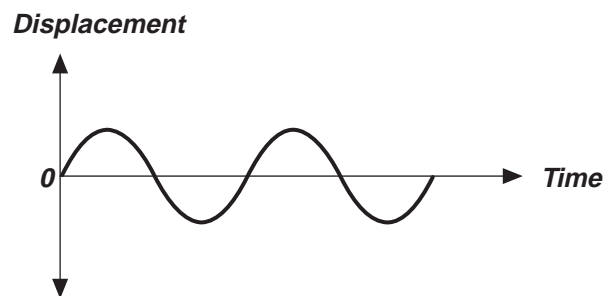

Figure 2.30: Simple sine waveform.

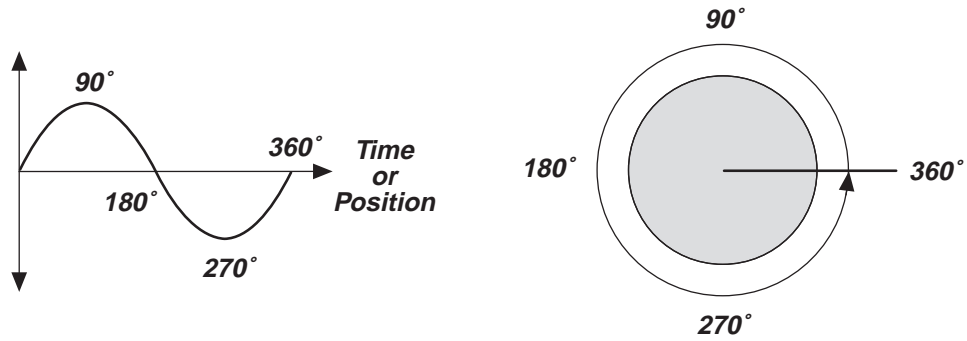

Figure 2.31: Comparison between one full wave and one rotation of a circle.

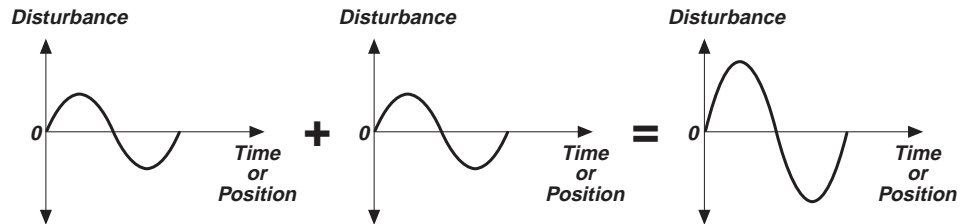

Figure 2.32: Addition of two waves.

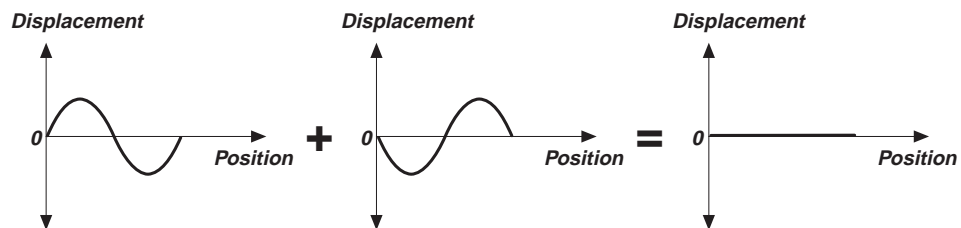

Figure 2.33: Addition of two waves out of phase by 180 degrees.

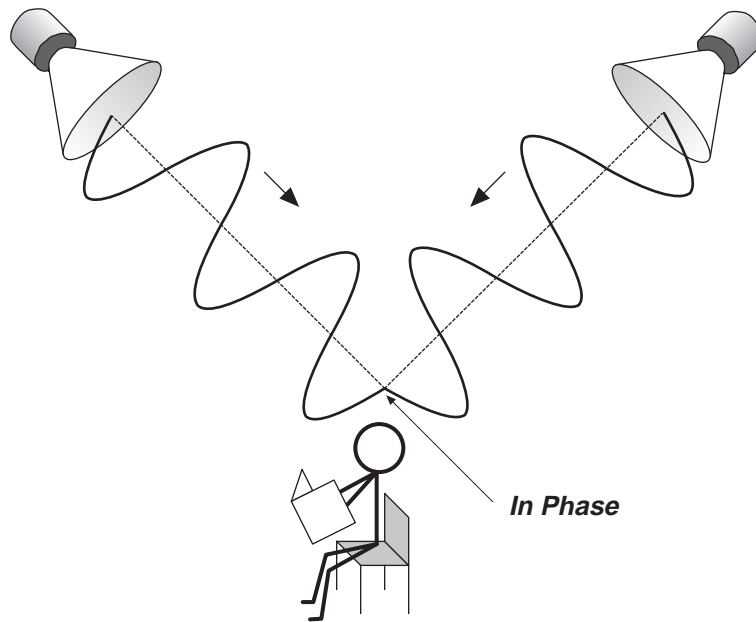

Figure 2.34: Constructive interference.

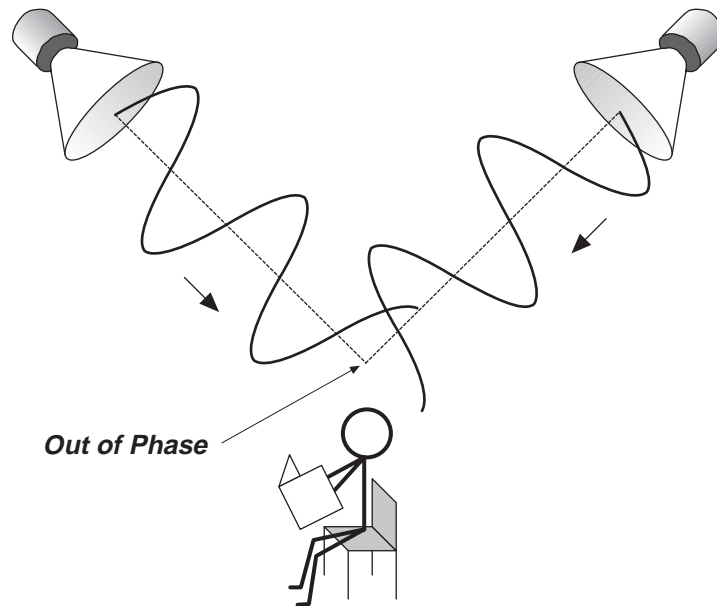

Figure 2.35: Destructive interference.

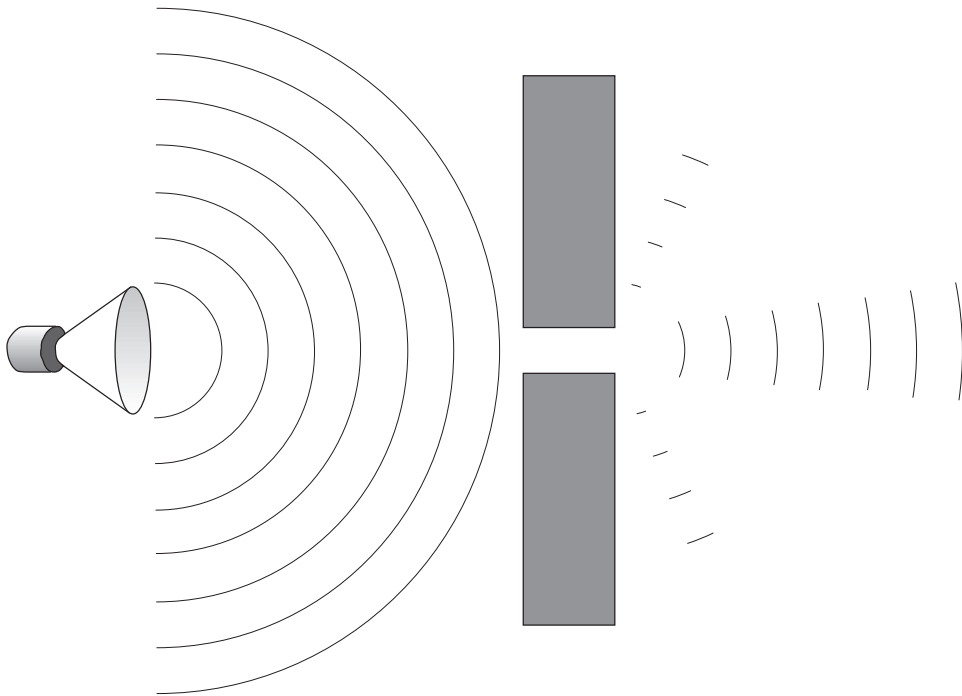

Figure 2.36: Obstacle with aperture receiving high frequency waves.

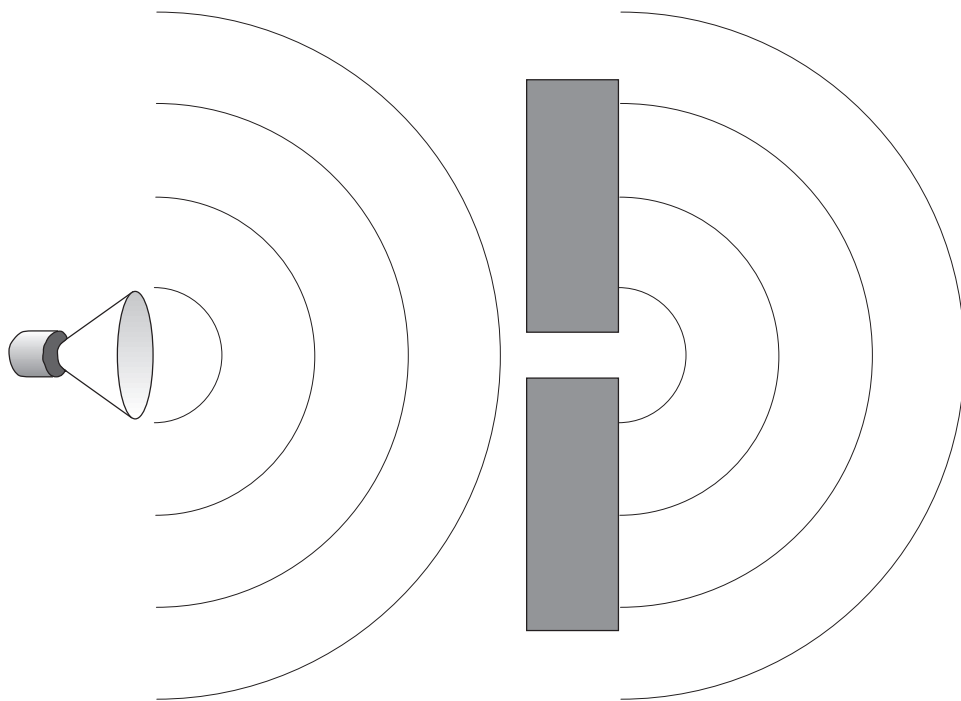

Figure 2.37: Low frequency behavior of obstacle and aperture.

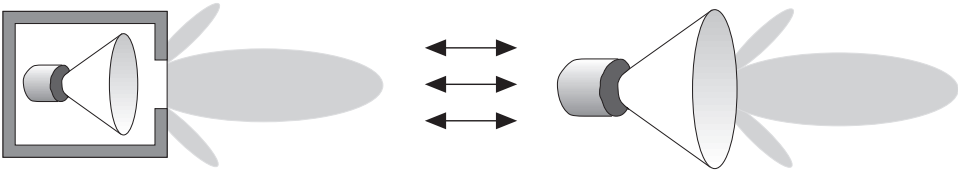

Figure 2.38: Comparison of diffraction behavior of a room with opening and a loudspeaker.

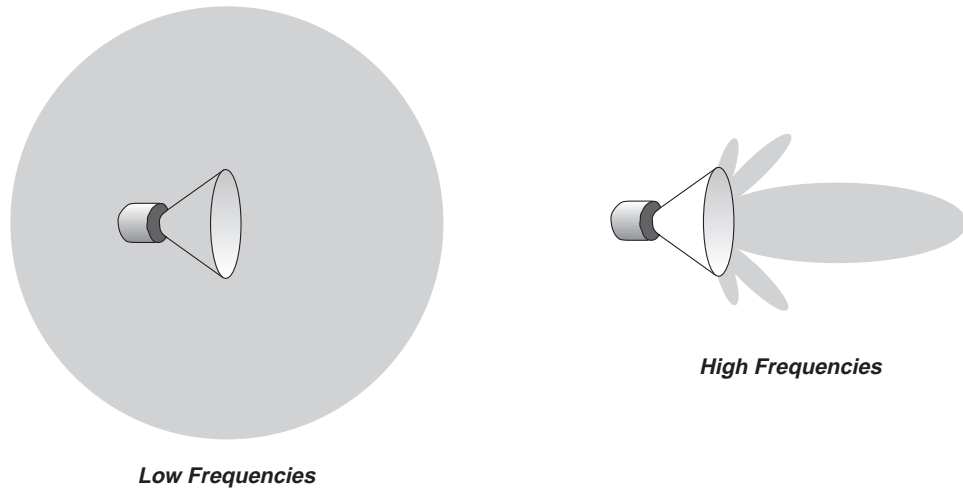

Figure 2.39: Dispersion characteristics of a speaker.

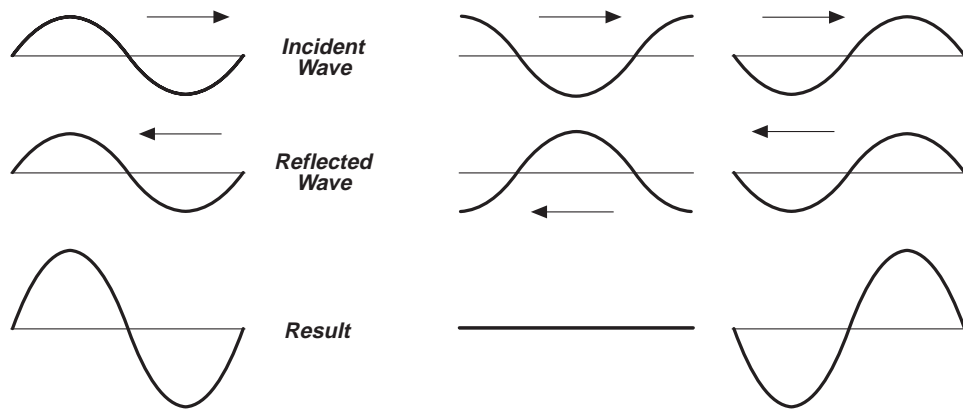

Figure 2.40: Standing wave produced by incident and reflected waves.

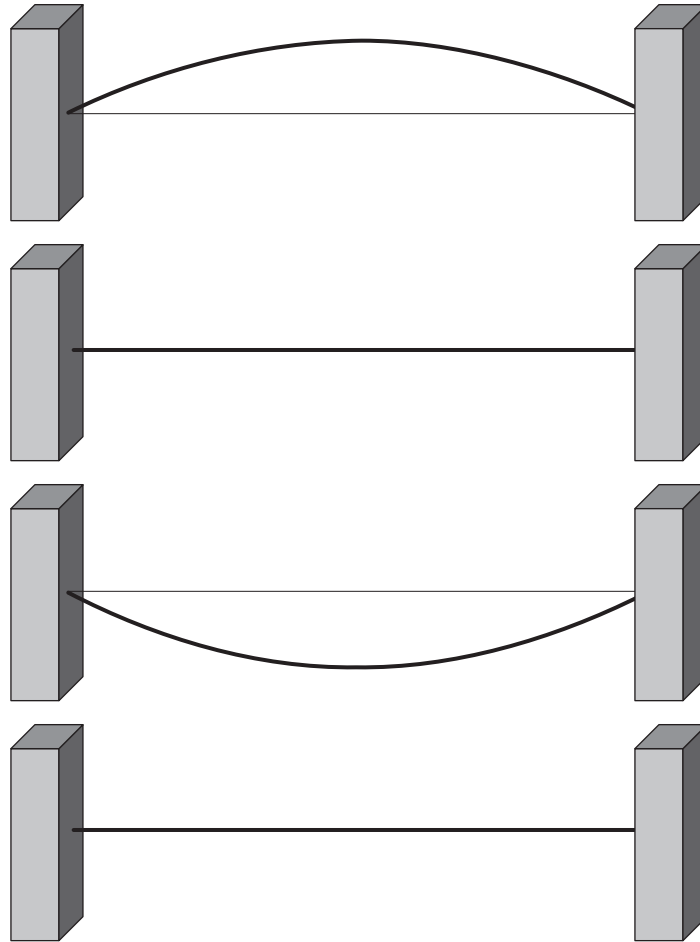

Figure 2.41: Simplest possible standing wave on a string.

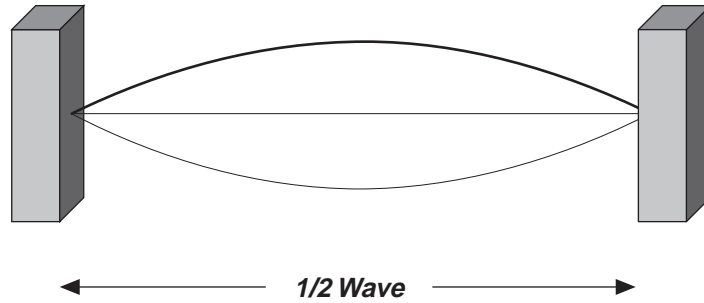

Figure 2.42: Simplest standing wave on a string during one cycle.

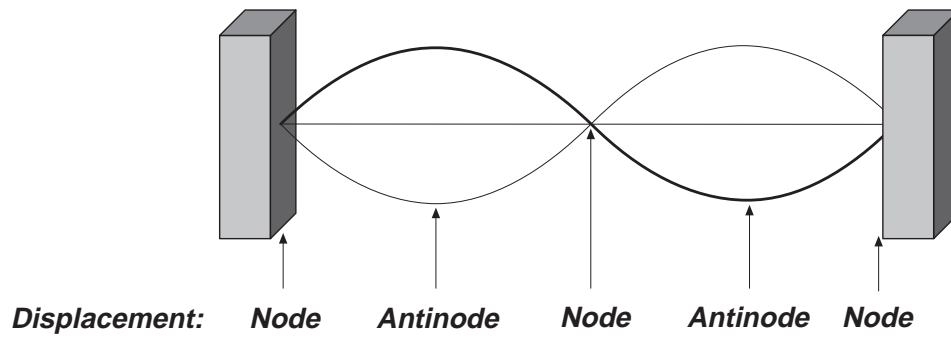

Figure 2.43: Second harmonic on a string showing position of nodes and antinodes.

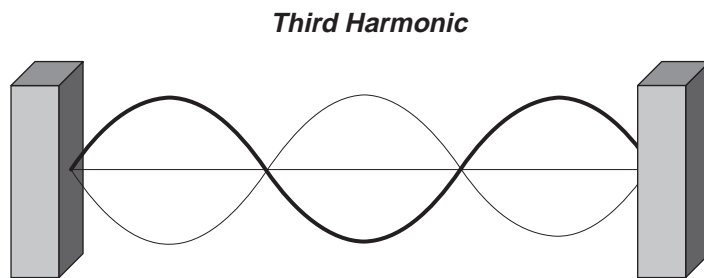
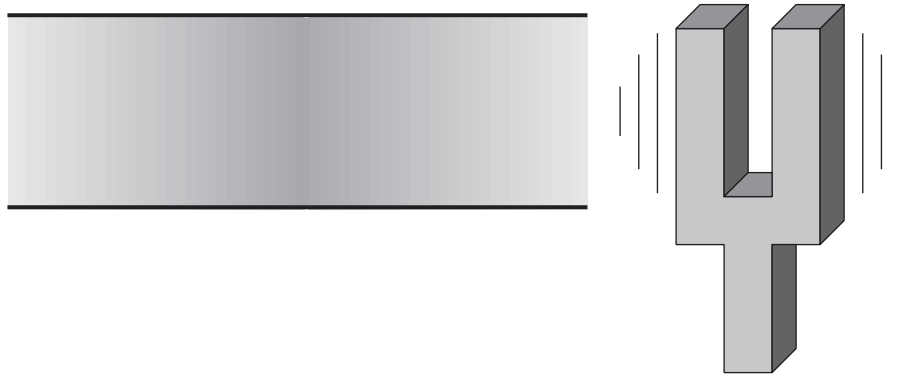

Figure 2.44: Third harmonic on a string clamped at both ends.



Or

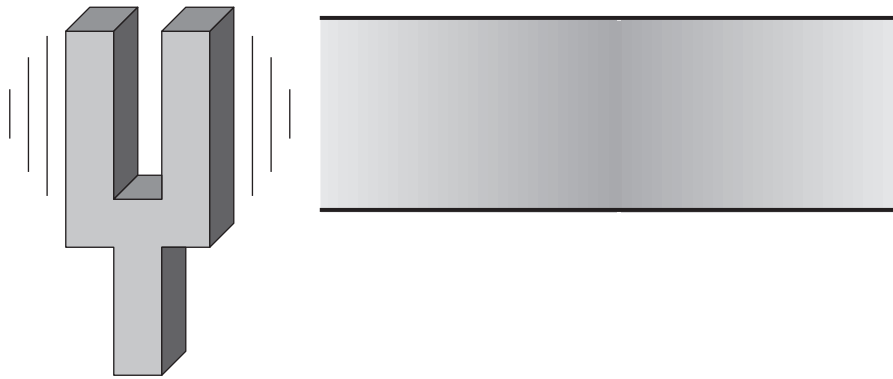

Figure 2.45: Setting up a standing wave in a tube.

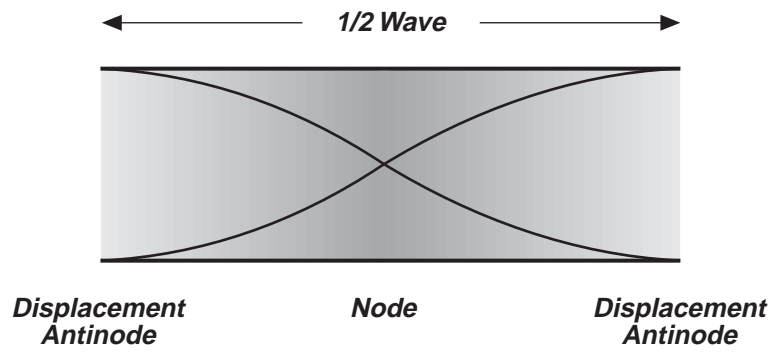

Figure 2.46: Simplest standing wave in a tube open at both ends.

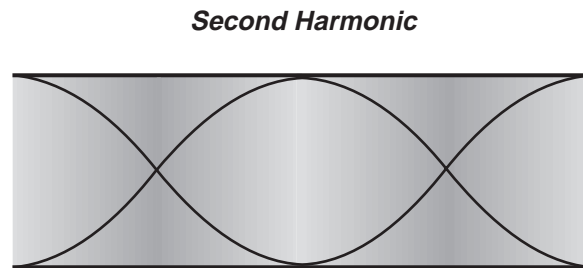

Figure 2.47: Second harmonic in tube open at both ends.

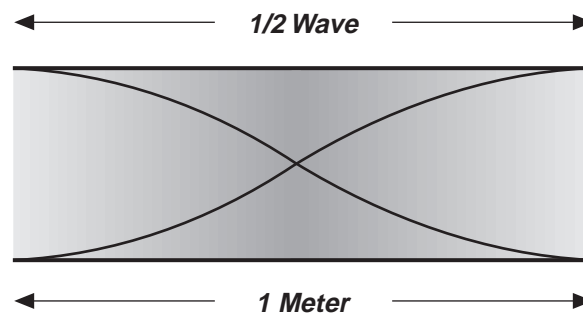

Figure 2.48: Fundamental in a tube.

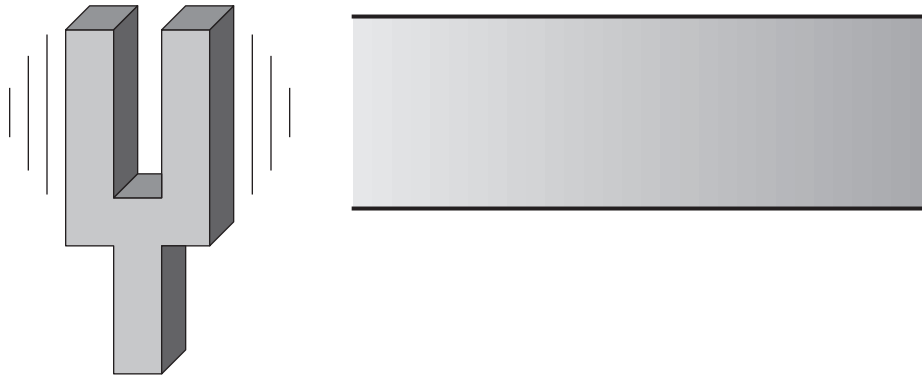

Figure 2.49: Tube open at one end excited by a tuning fork.

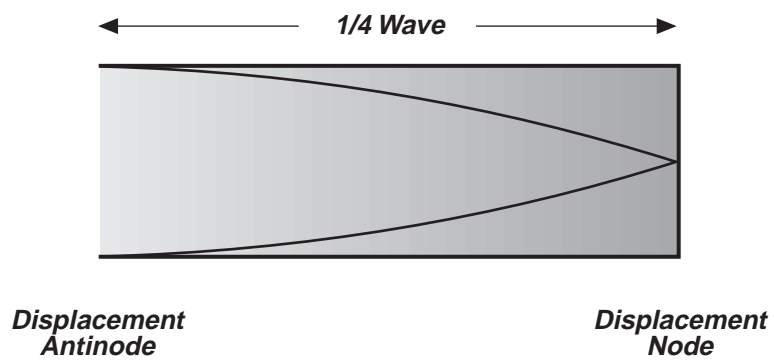

Figure 2.50: Fundamental in tube open at one end.

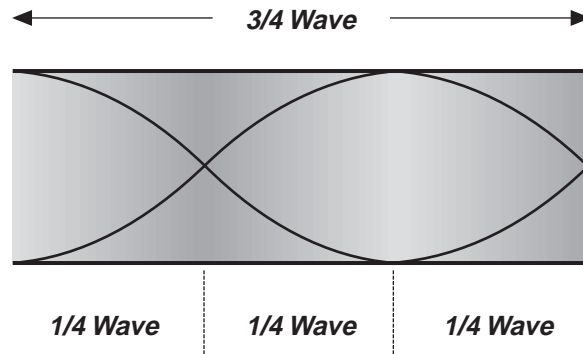

Figure 2.51: Next more complicated standing wave; the third harmonic.

Fifth Harmonic

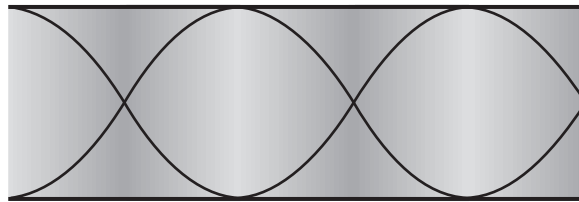

Figure 2.52: Fifth harmonic.

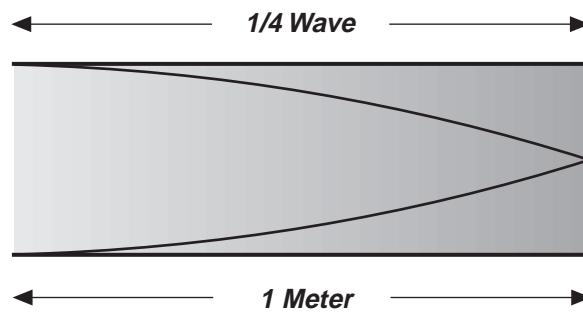

Figure 2.53: Standing wave in a tube 1 meter long; fundamental.

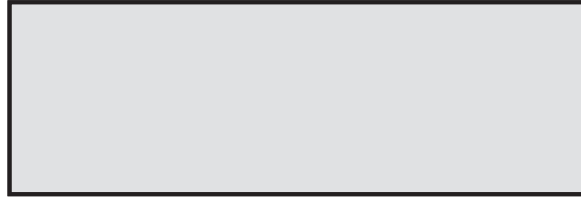

Figure 2.54: Tube closed at both ends.

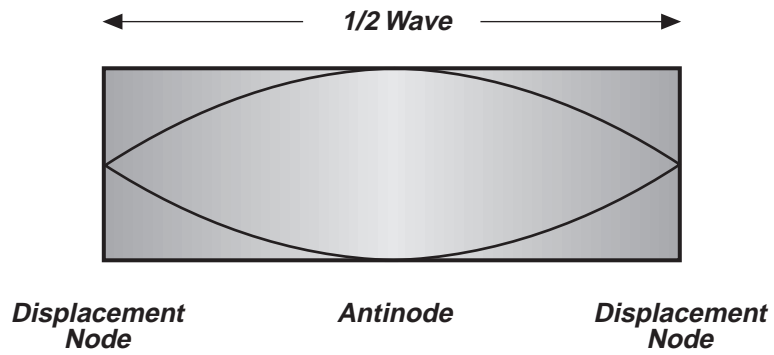

Figure 2.55: Fundamental of a tube closed at both ends.

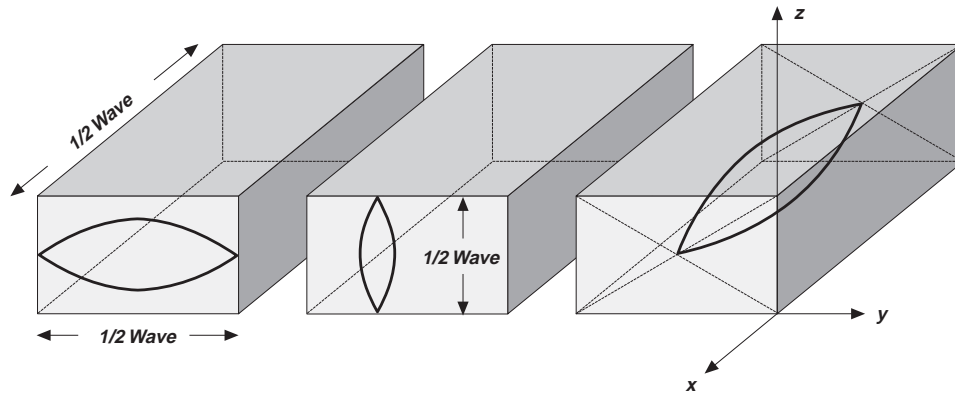

Figure 2.56: Room where independent standing waves can be set up in the x, y, and z directions.

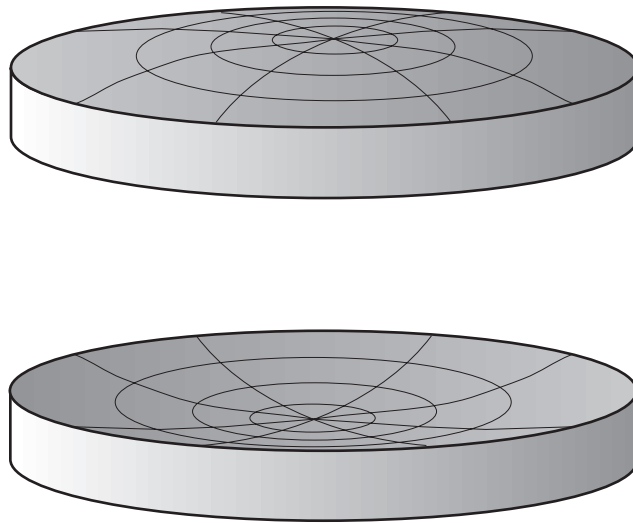

Figure 2.57: A drumhead fixed at its edges and its fundamental mode of vibration.

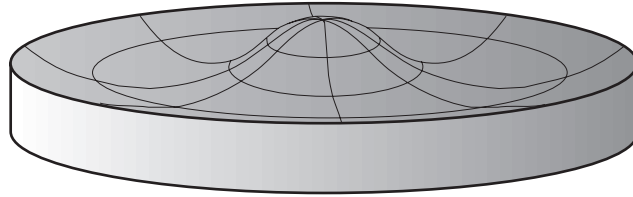

Figure 2.58: Overtone on a drumhead.

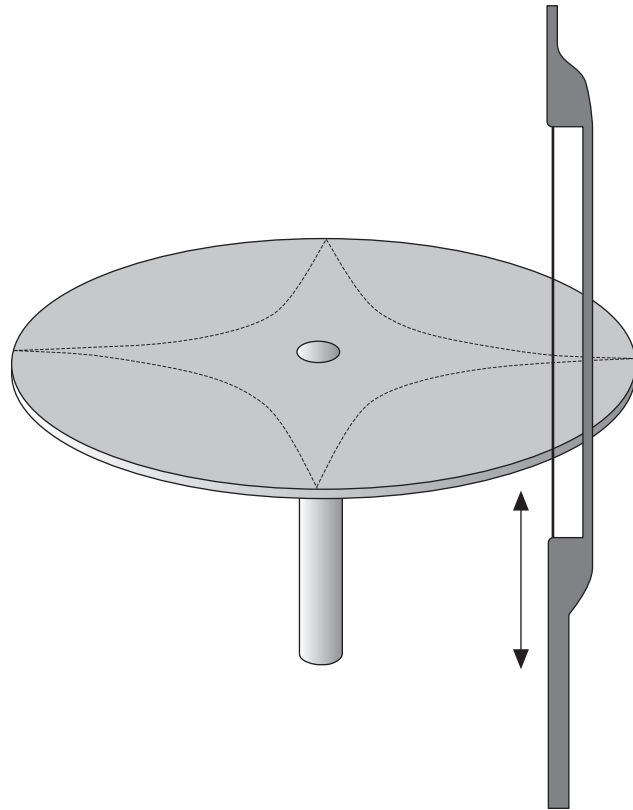

Figure 2.59: Standing wave pattern on a Chladni plate.

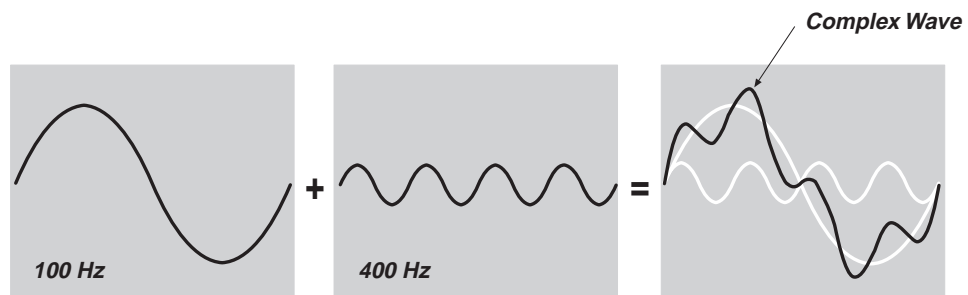

Figure 2.60: Complex wave created by the superposition of a 100 Hz fundamental and its fourth harmonic.

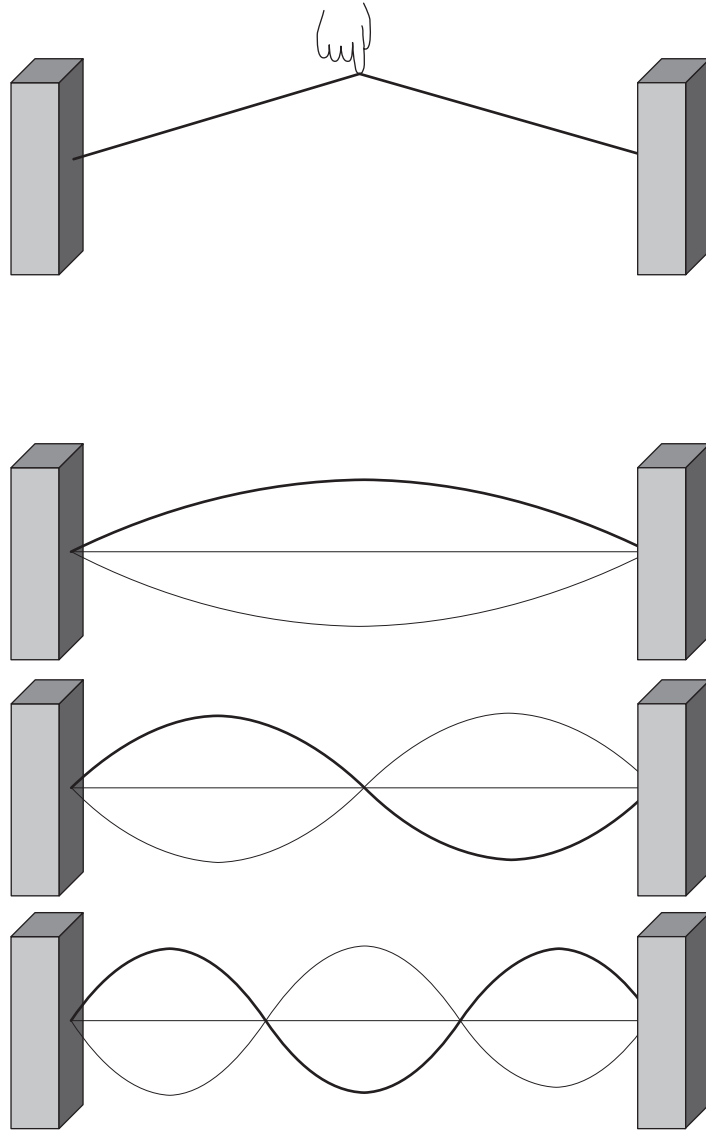

Figure 2.61: Violin string plucked by a finger and producing all sorts of harmonics.

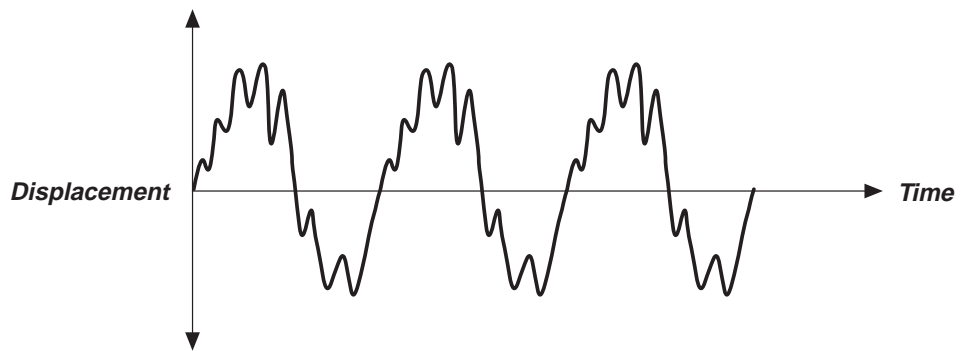
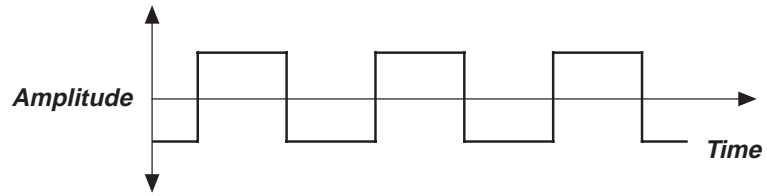

Figure 2.62: Complex wave generated by plucking string.



| | <i>Frequency</i> | <i>Relative Amplitude</i> |
|----------|------------------|---------------------------|
| | f | 1 |
| | | |
| | $3f$ | $1/3$ |
| | | |
| | $5f$ | $1/5$ |
| \vdots | \vdots | \vdots |
| | nf | $1/n$ |

$n = \text{odd integer}$

Figure 2.63: Square wave; it is made up of many harmonics.

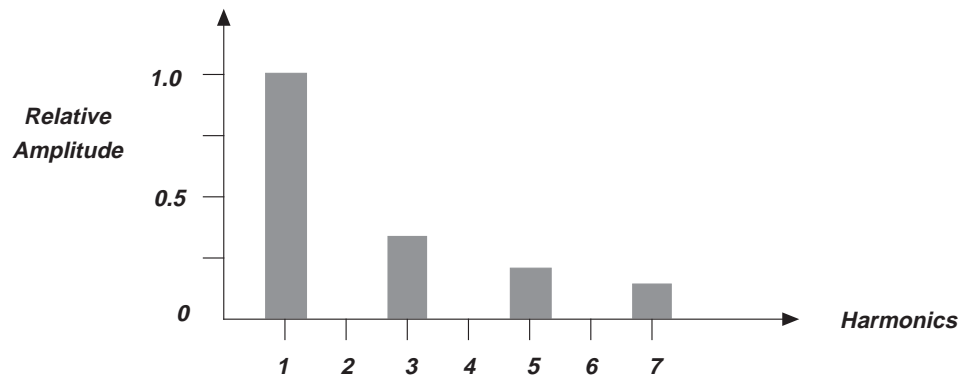
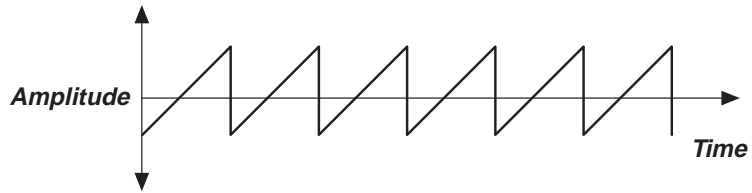

Figure 2.64: Spectrum of a square wave.



| | <i>Frequency</i> | <i>Relative Amplitude</i> |
|---|------------------|---------------------------|
| | f | 1 |
| | $2f$ | $1/2$ |
| | $3f$ | $1/3$ |
| | $4f$ | $1/4$ |
| | $5f$ | $1/5$ |
| ⋮ | ⋮ | ⋮ |
| | nf | $1/n$ |

$n = \text{integer}$

Figure 2.65: Sawtooth wave and its harmonic content.

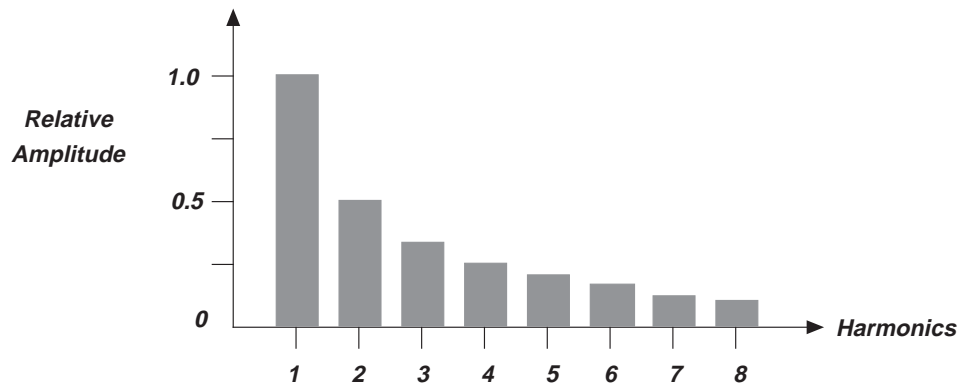

Figure 2.66: Spectrum of a sawtooth wave.

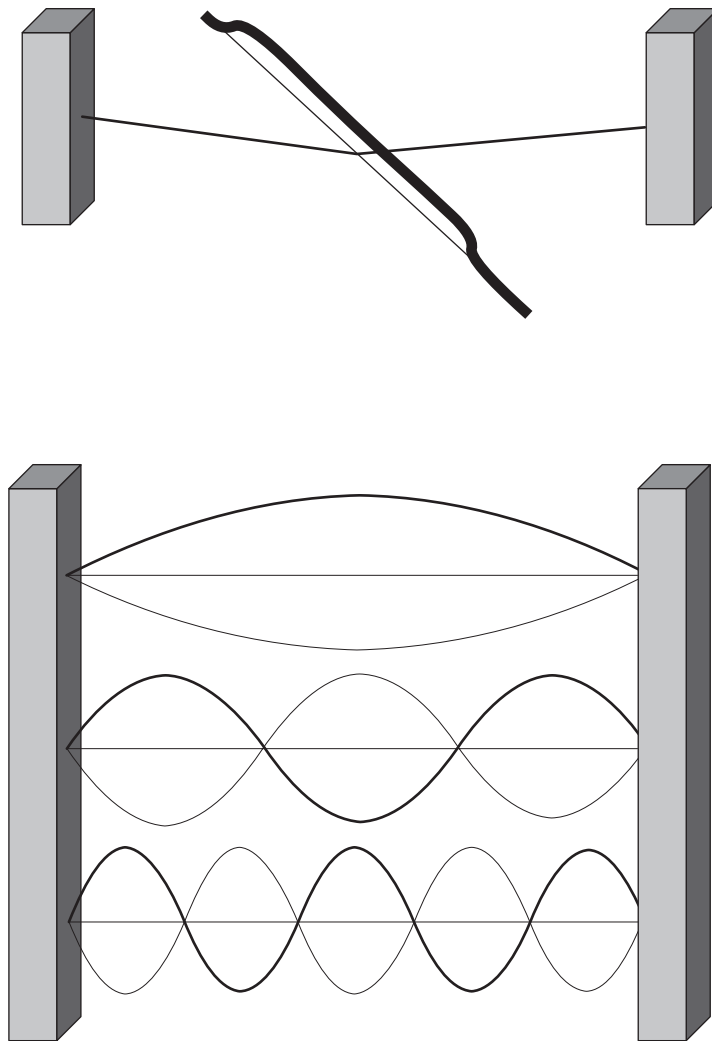

Figure 2.67: A string bowed at its middle and harmonics which are excited.

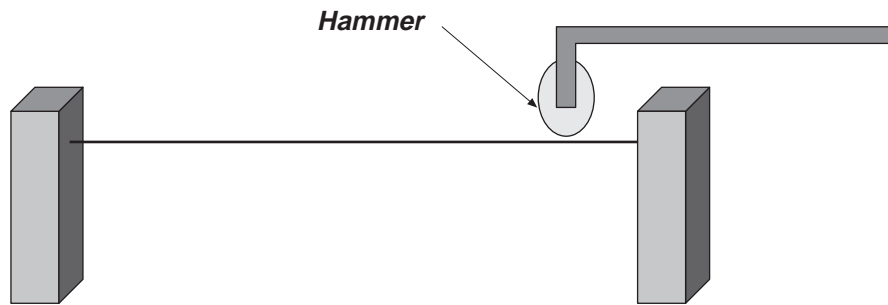

Figure 2.68: String on a piano struck by hammer at a distance $1/10$ the string length from one end.

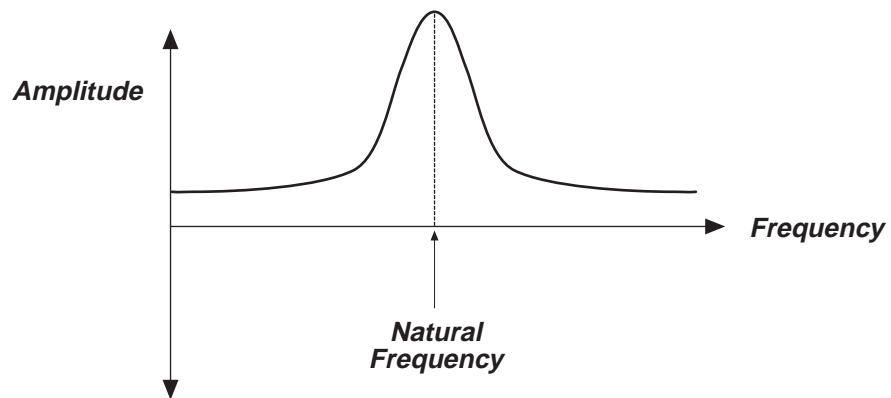

Figure 2.69: Vibrations of an object at different excitation frequencies.

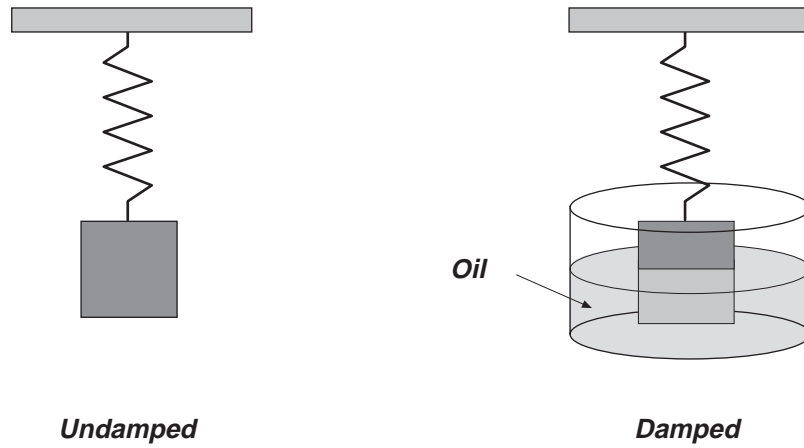

Figure 2.70: Oscillations of a mass on a spring, undamped and damped when submersed in oil.

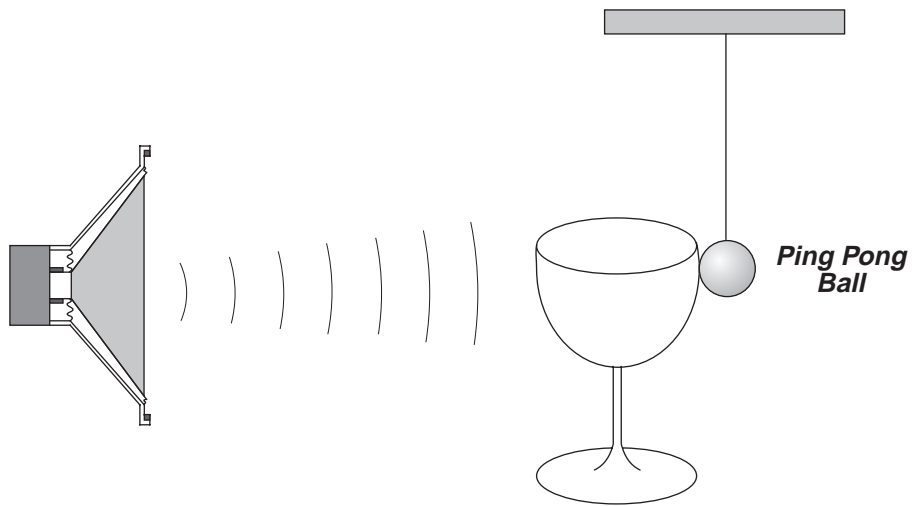

Figure 2.71: Resonance of wine glass excited by sound.

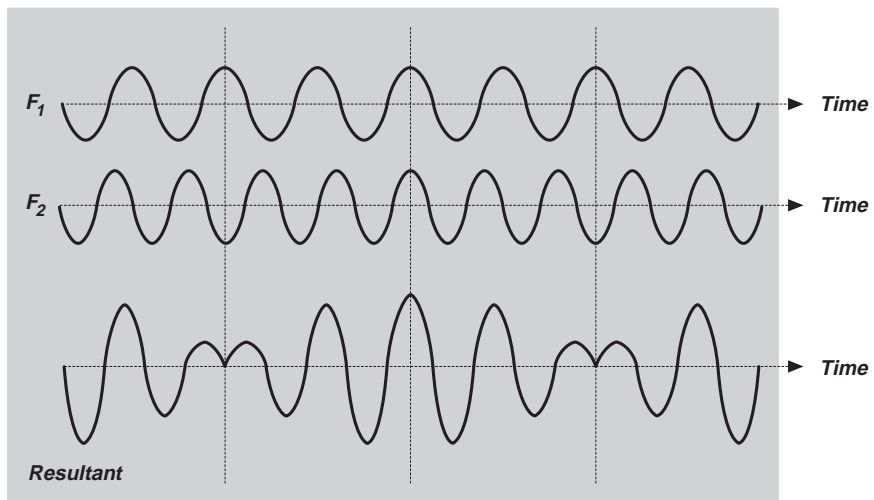

Figure 2.72: Beats caused by the combination of two waves with slightly different frequencies.

Chapter 3

Decibels



Figure 3.1: Decibel meter.

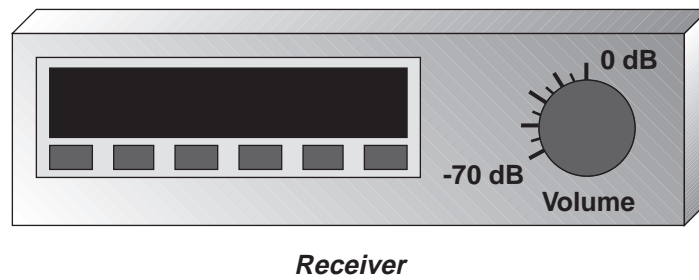

Figure 3.2: Receiver with volume control marked in dB.

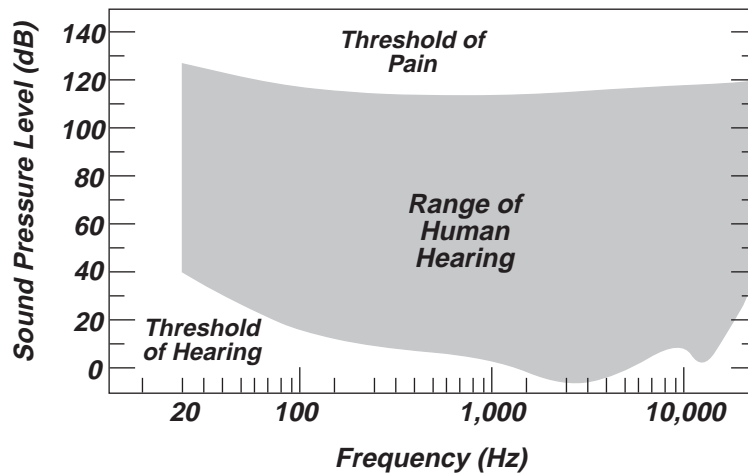

Figure 3.3: Response of human ears at the threshold of hearing.

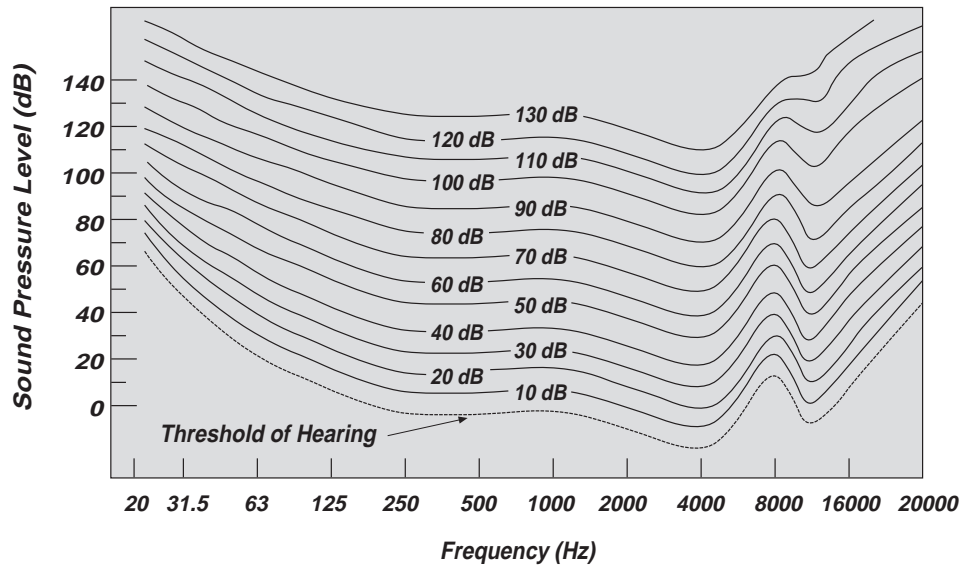

Figure 3.4: Response of human ears for various sound levels: Fletcher-Munson curves.

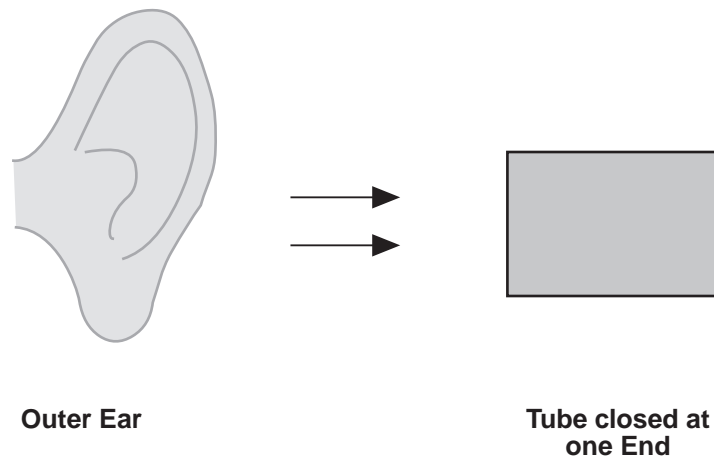

Figure 3.5: Outer ear approximated by a tube closed at one end.

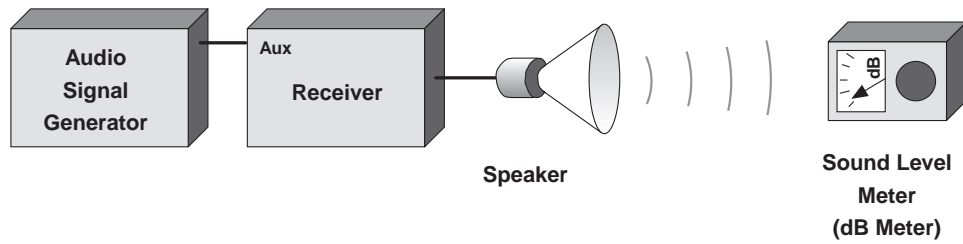

Figure 3.6: Measuring the frequency response of a speaker.

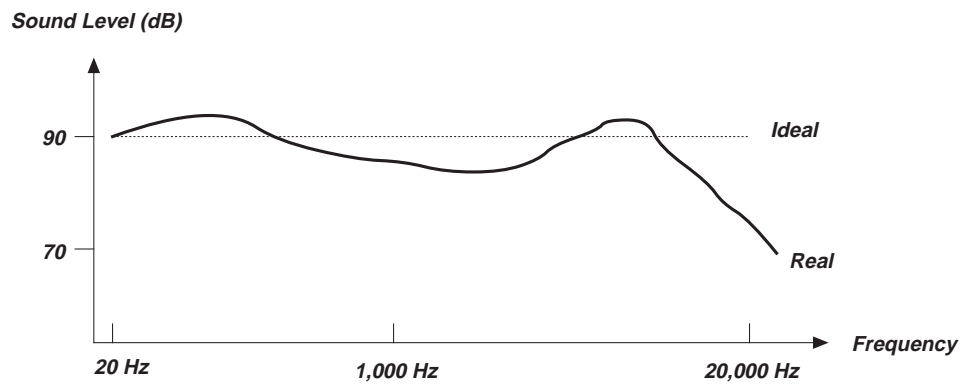

Figure 3.7: Frequency response of a speaker.

Chapter 4

Loudspeakers

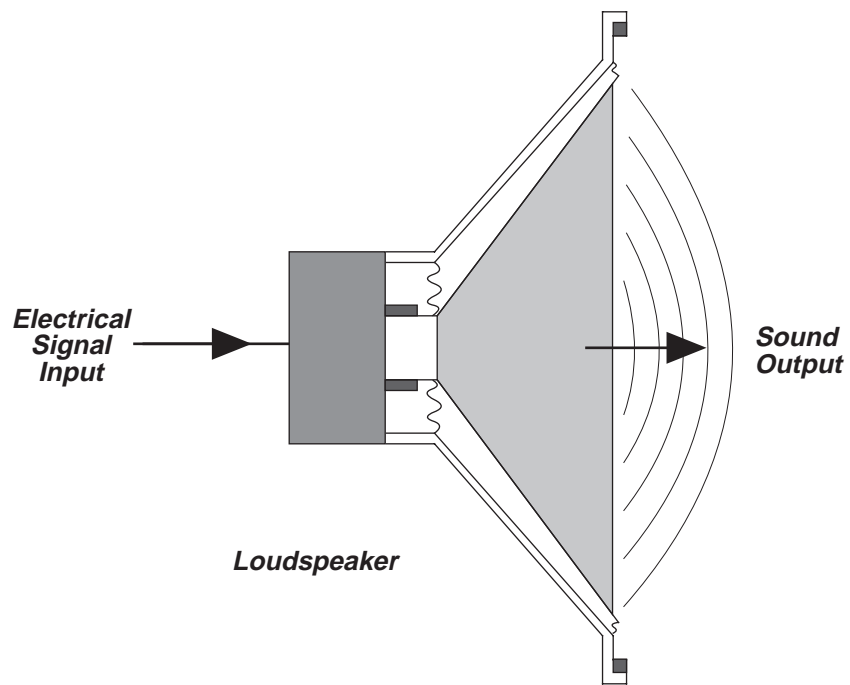

Figure 4.1: Role of loudspeaker.

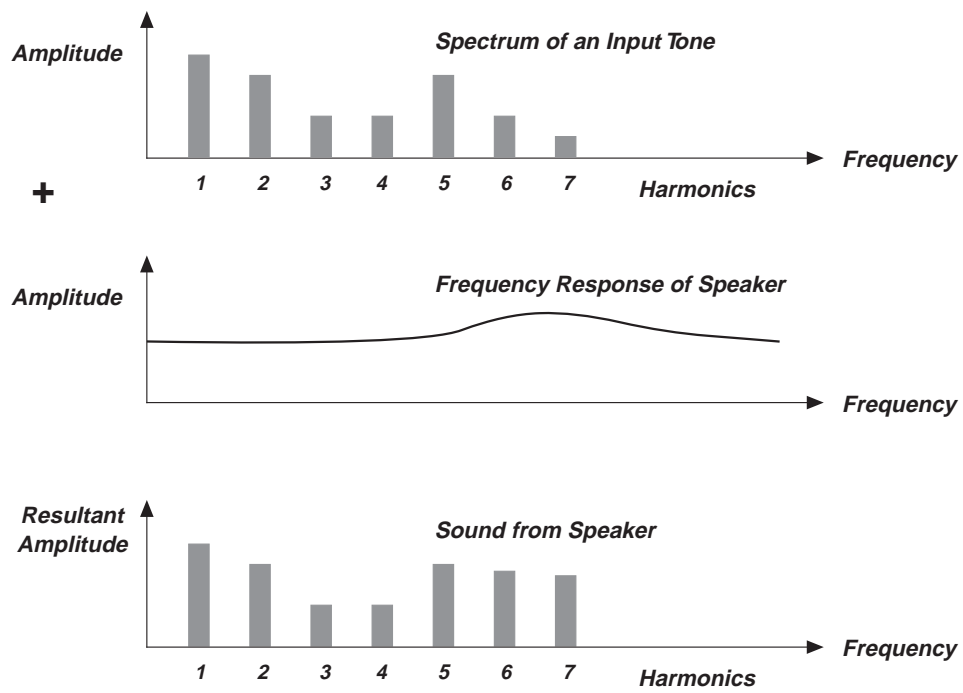

Figure 4.2: Distortion of spectrum of original waveform by non-flat frequency response of speaker.

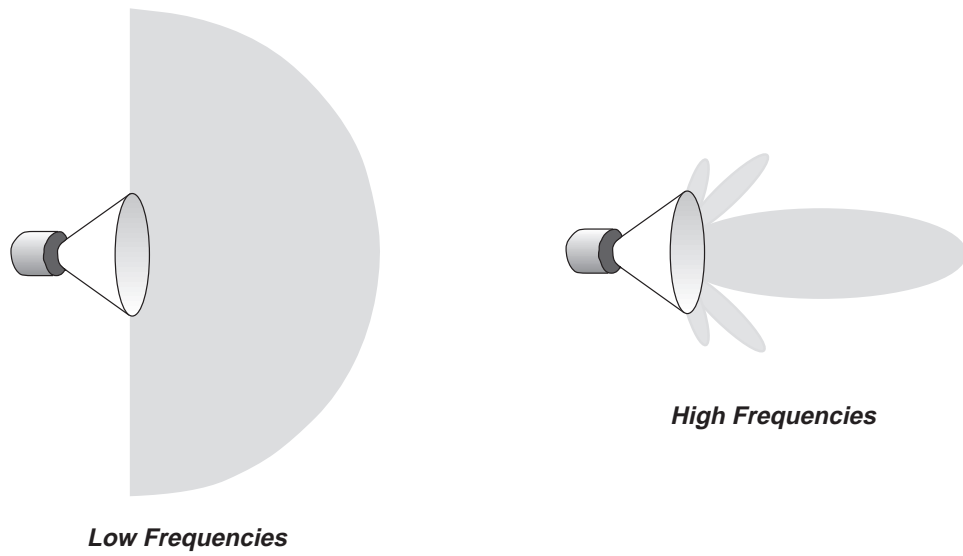

Figure 4.3: Dispersion properties of speakers.

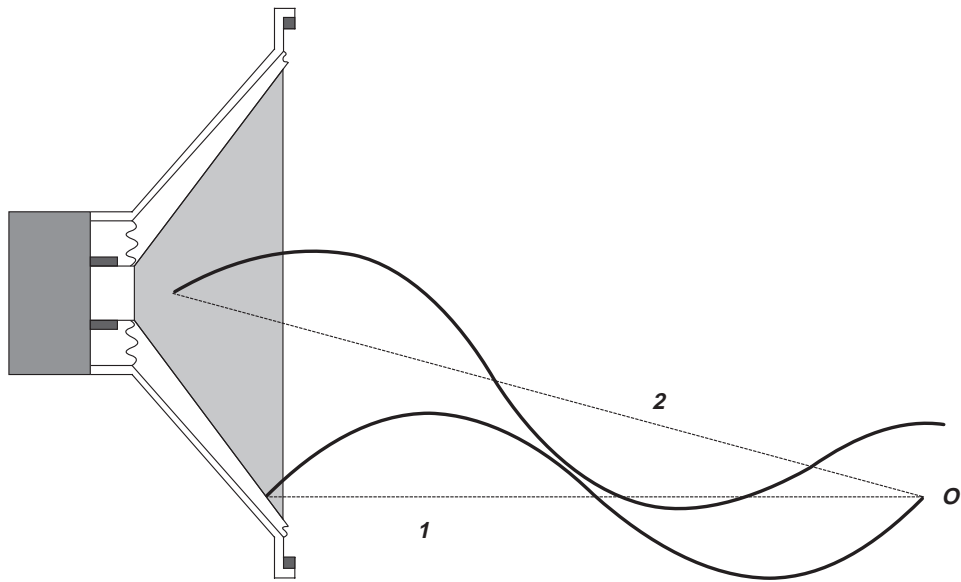

Figure 4.4: Two low frequency waves from speaker arriving at O.

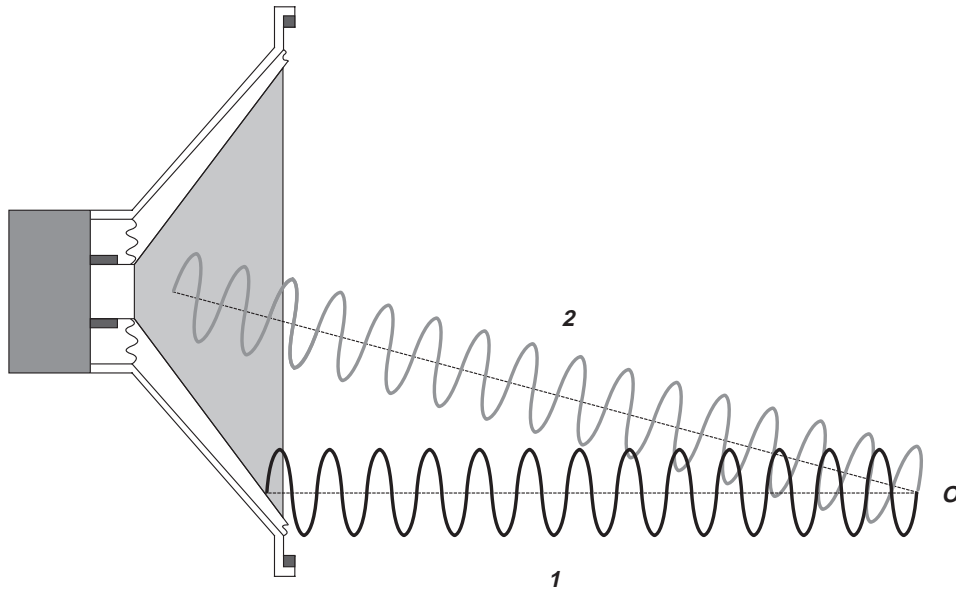

Figure 4.5: Two high frequency waves from speaker arriving at O.

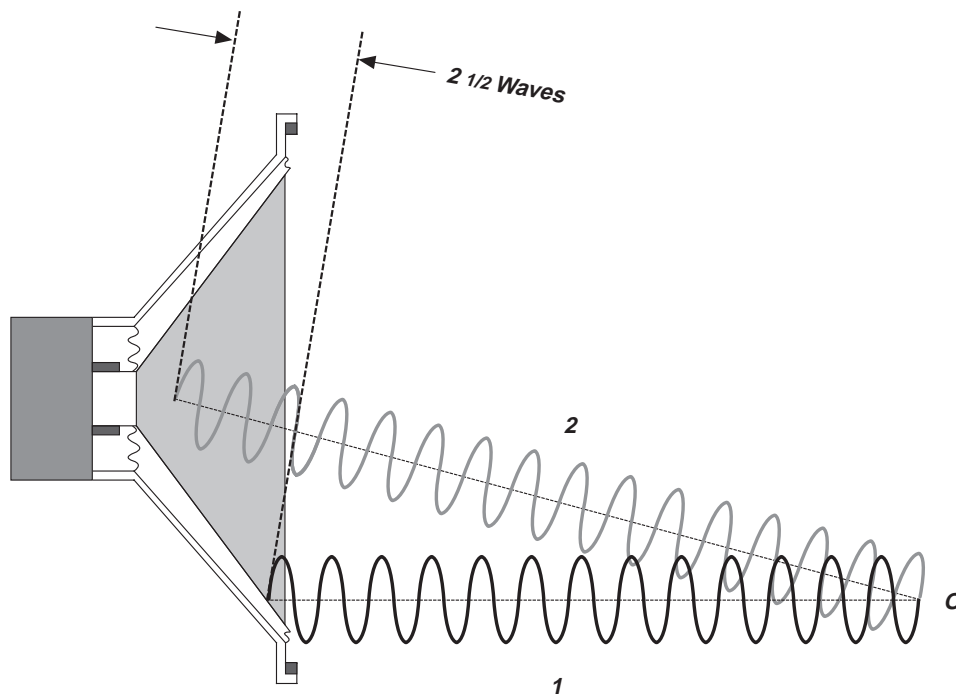

Figure 4.6: Details of waves 2 and 1 at high frequencies.

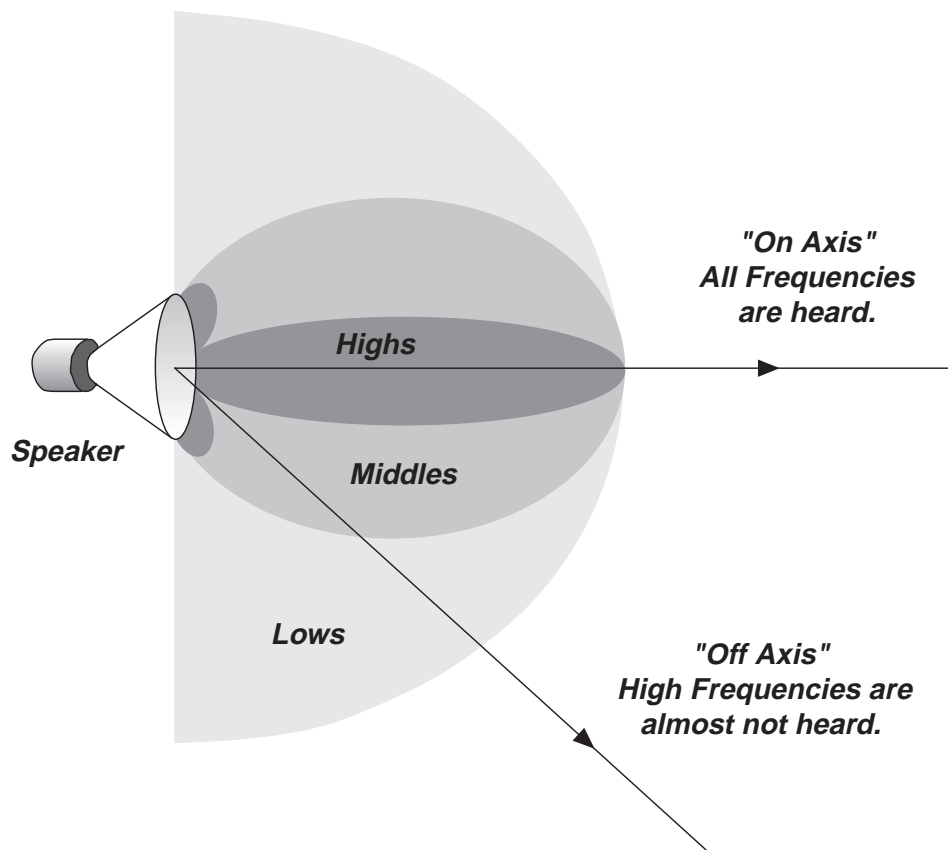

Figure 4.7: Sound dispersion of a driver as the frequency is increased.

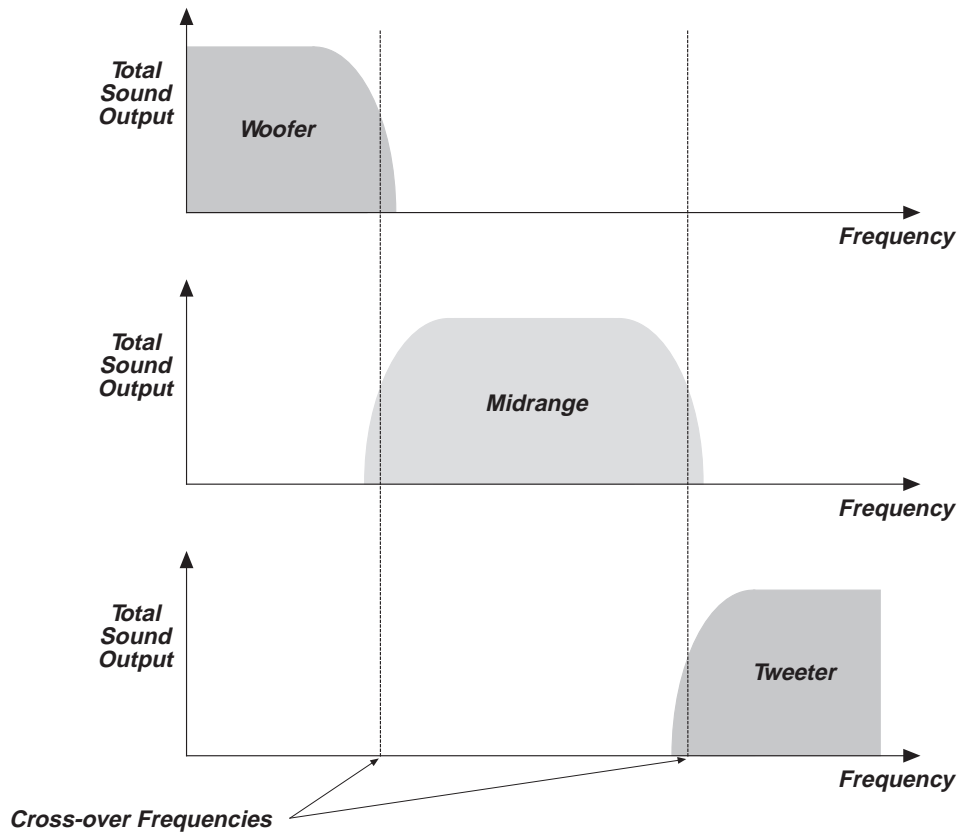

Figure 4.8: Division of audio spectrum for a three-way loudspeaker.

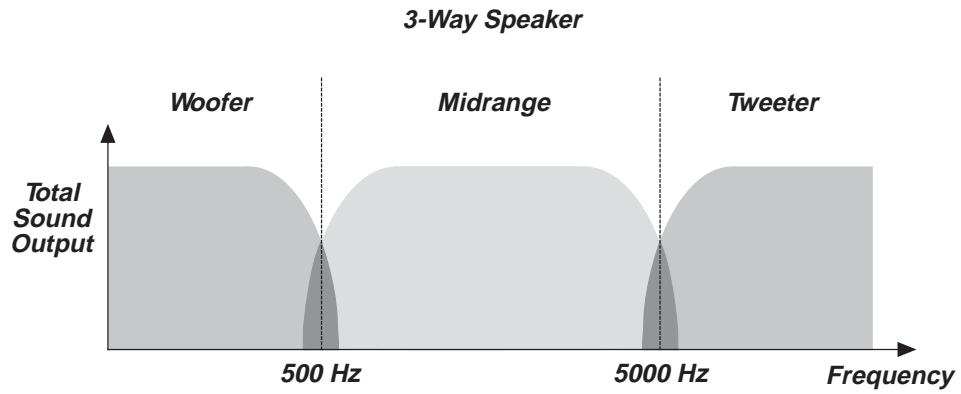

Figure 4.9: Net effect of subdividing the whole audio range into three sections.

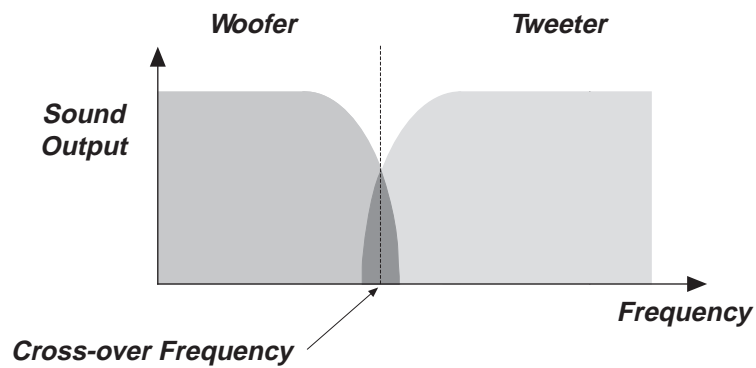

Figure 4.10: Subdivision of audio spectrum in a two-way system.

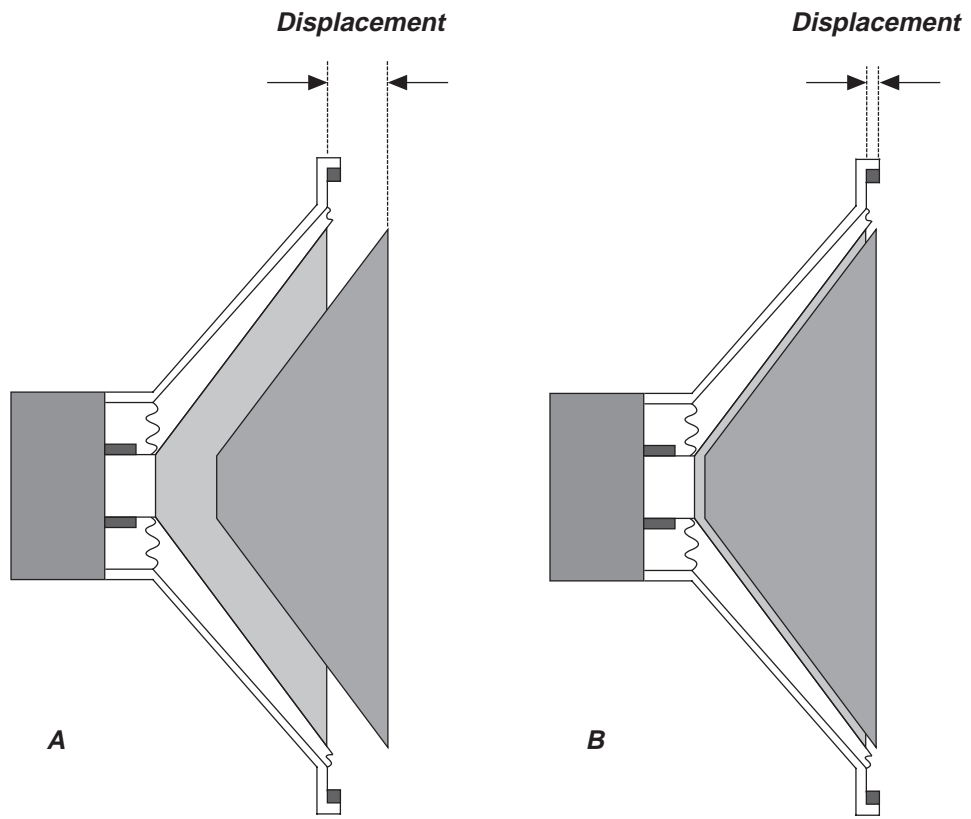

Figure 4.11: Amount of sound produced depends on volume displacement. A is louder than B.

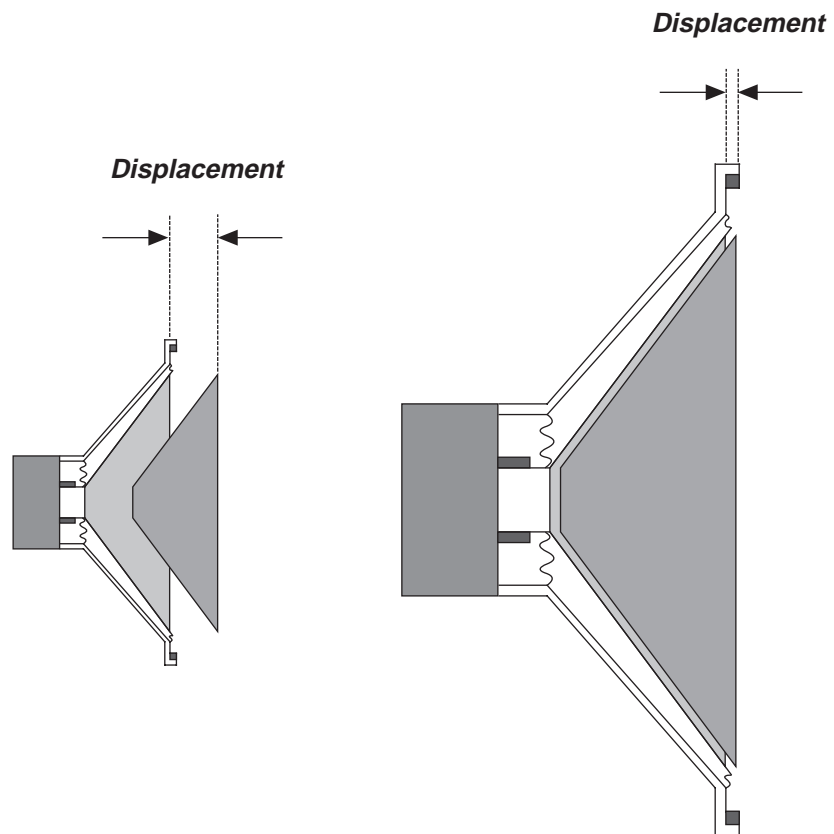

Figure 4.12: To produce same amount of sound by both drivers at the same frequency, the small one has to move through a larger distance than the big one.

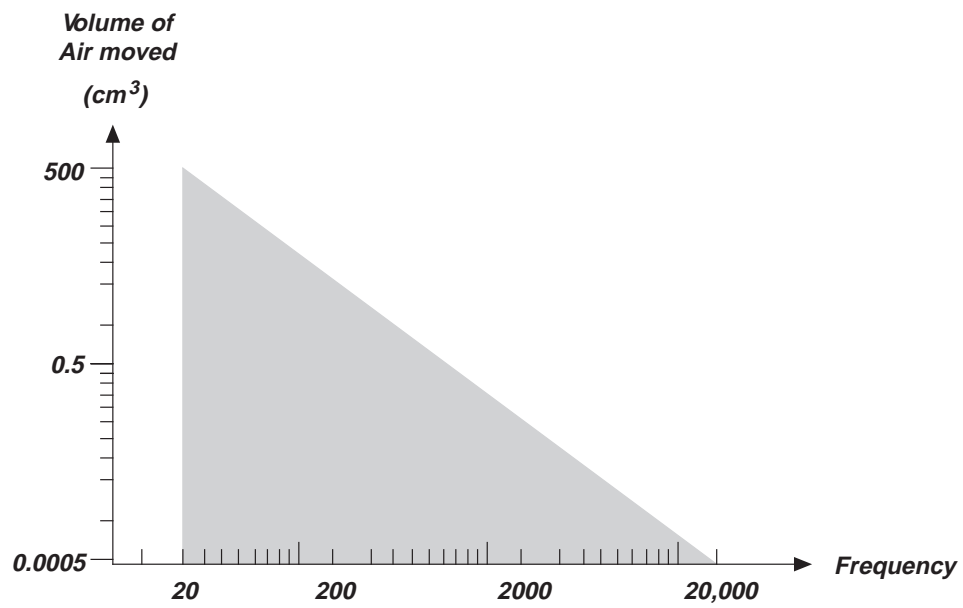

Figure 4.13: Volume of air moved by loudspeaker as a function of frequency to produce same loudness of sound.

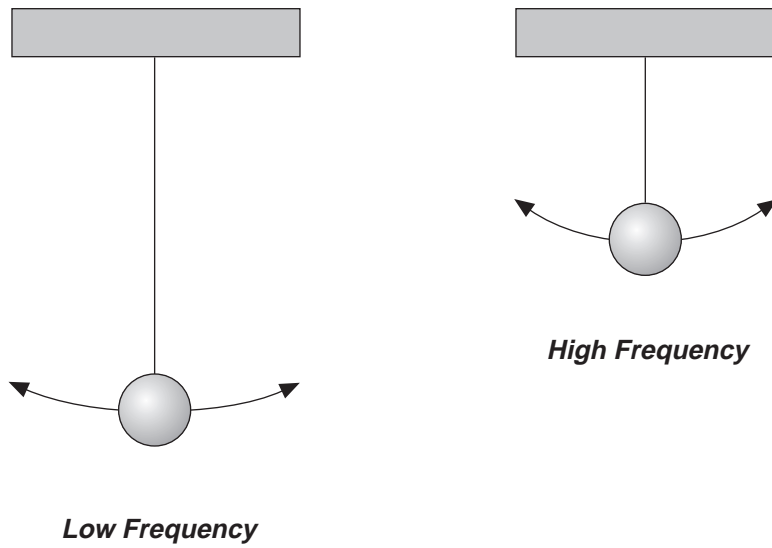

Figure 4.14: Low frequency and high frequency simple pendulums doing different amounts of work per second for same amplitude of displacement.

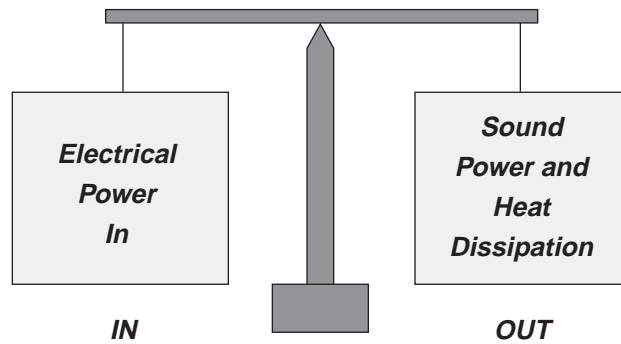

Figure 4.15: Balance between electrical power going to driver and the production of sound power and heat dissipation by driver.

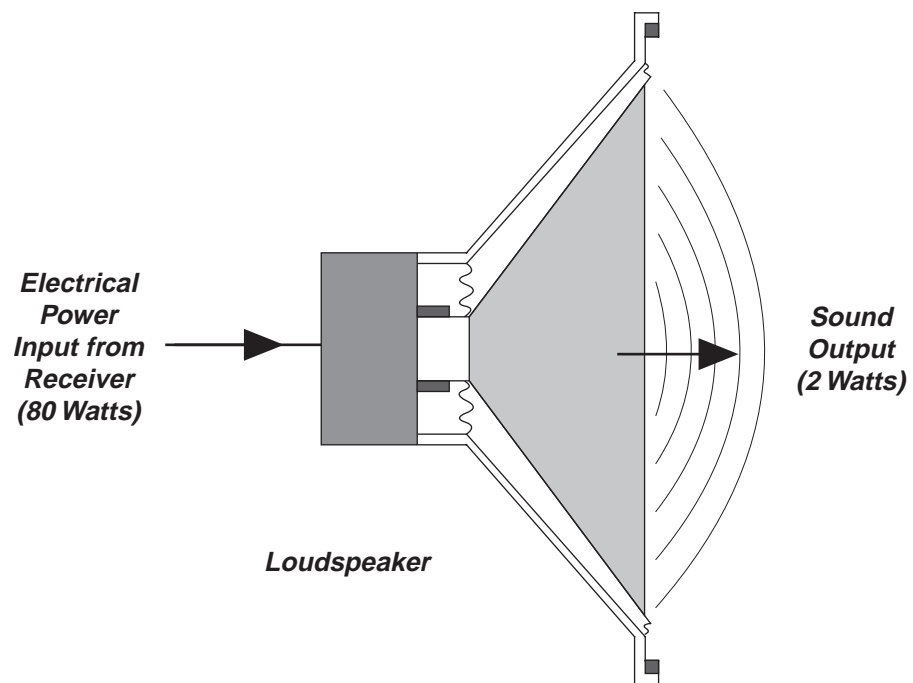

Figure 4.16: Example of a loudspeaker whose efficiency is less than 100%.

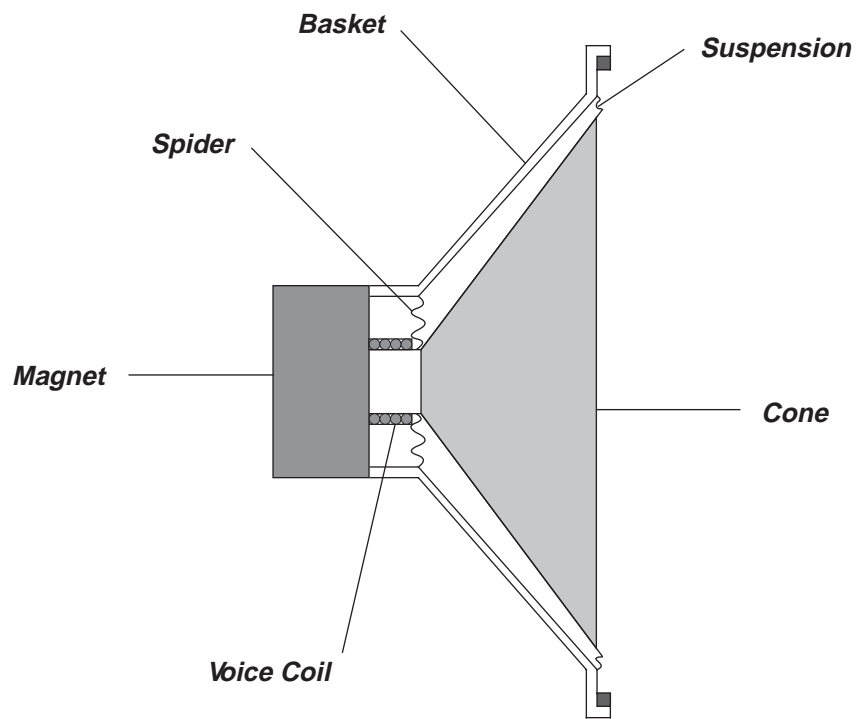
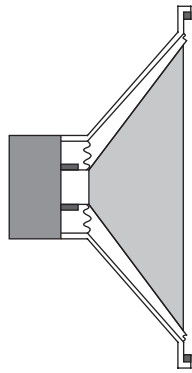
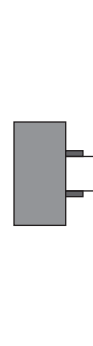

Figure 4.17: Basic cone speaker.



Cone-shaped Diaphragm



Flat Diaphragm

Figure 4.18: Comparison of cone-shape over flat shape for mechanical strength when thin material is used.

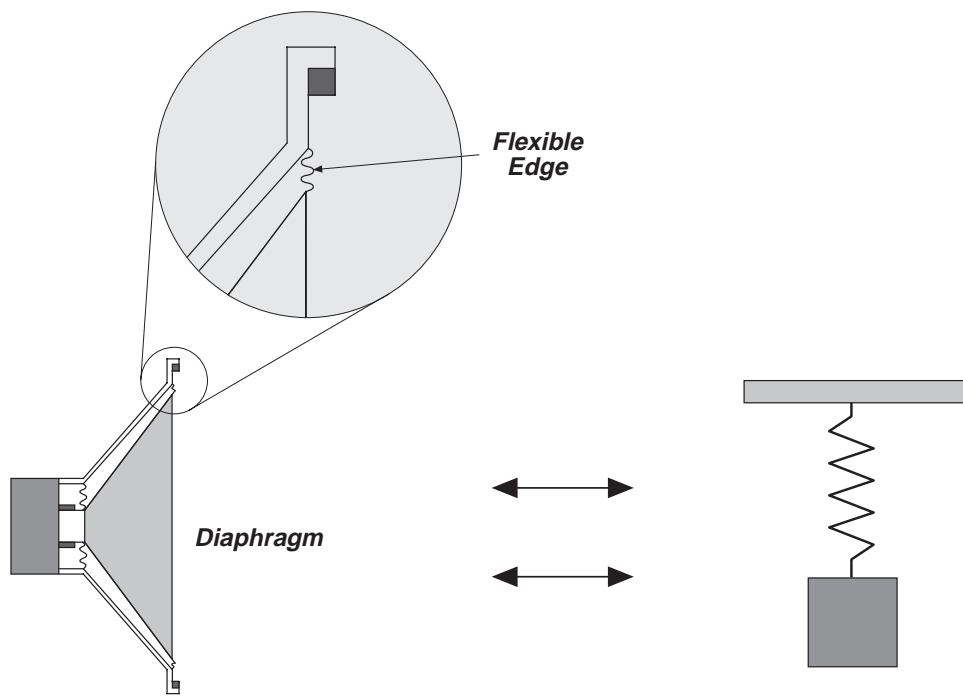

Figure 4.19: Modeling of diaphragm action by mass-spring oscillating system.

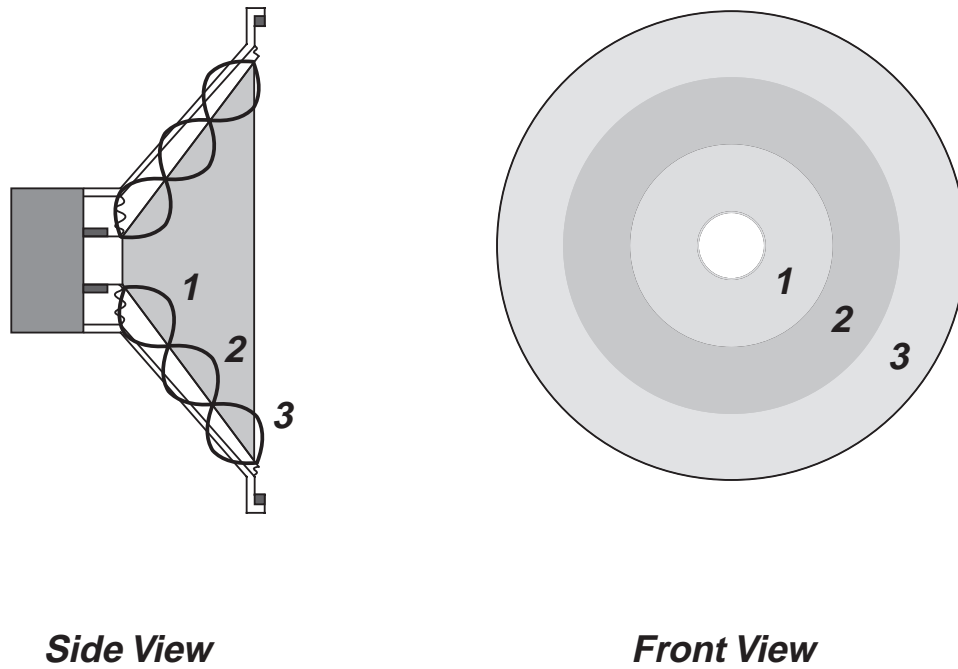

Figure 4.20: Standing wave on diaphragm of driver.

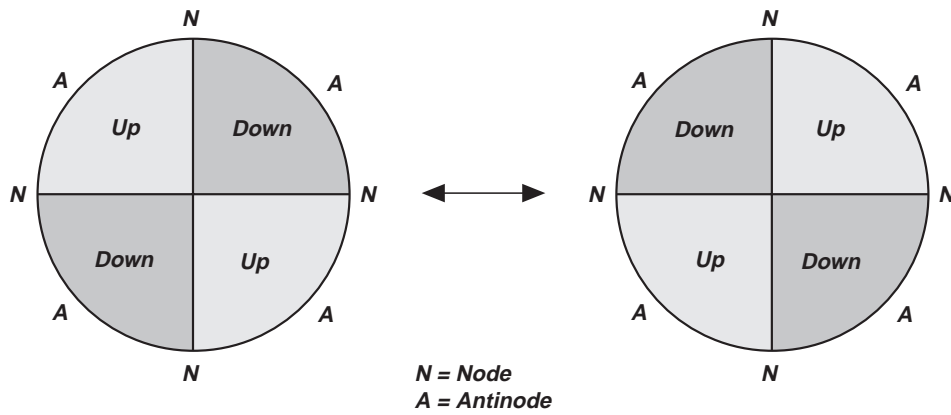

Figure 4.21: Standing wave around rim of diaphragm.

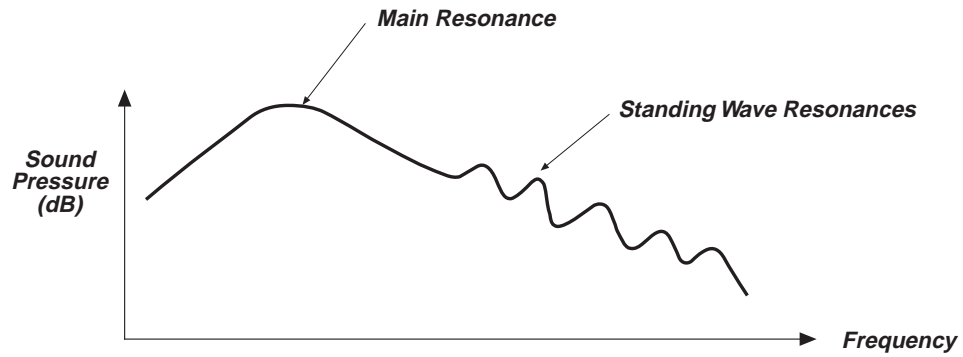

Figure 4.22: Typical frequency response of a cone speaker.



Figure 4.23: Baffle problem in cone driver.

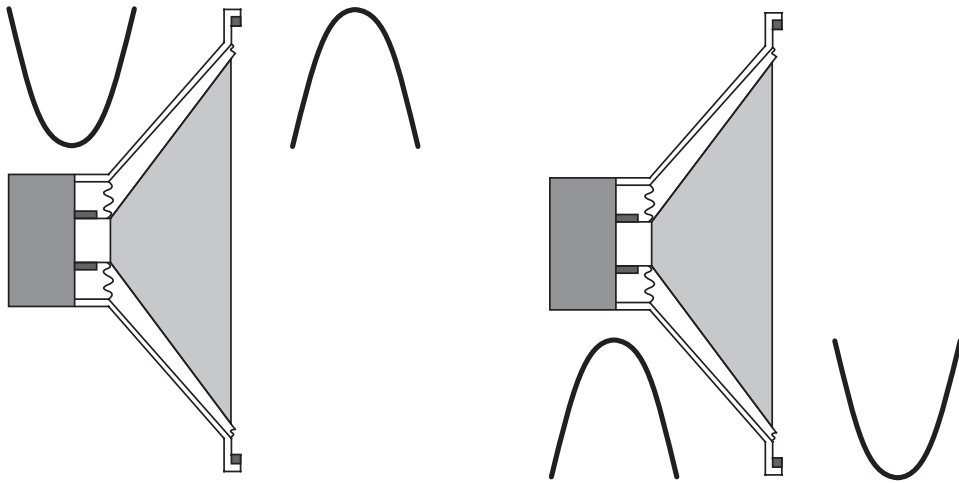

Figure 4.24: Front and rear of cone speakers are 180° out of phase.

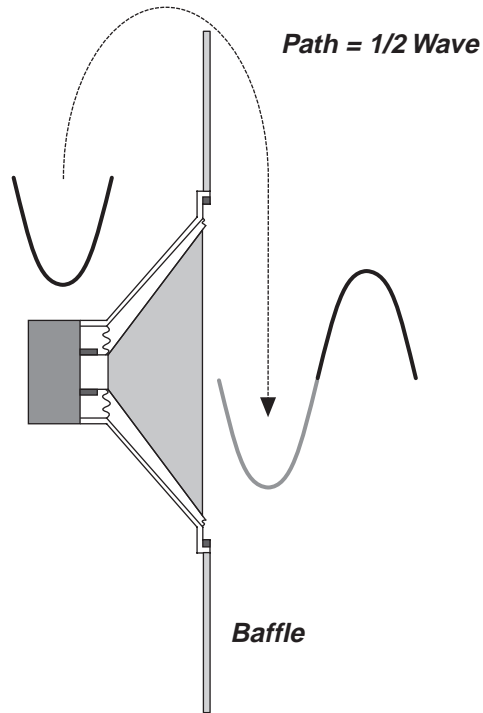

Figure 4.25: Baffle action.

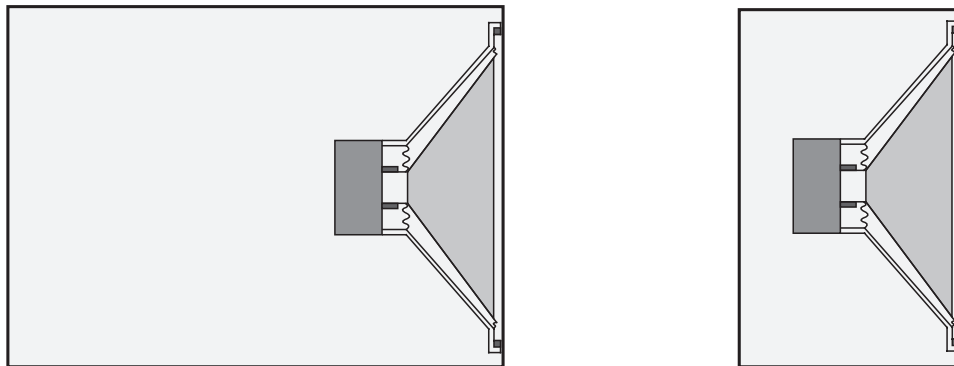

Figure 4.26: Two possible approaches for trapping rear sound in a speaker by means of an enclosure.

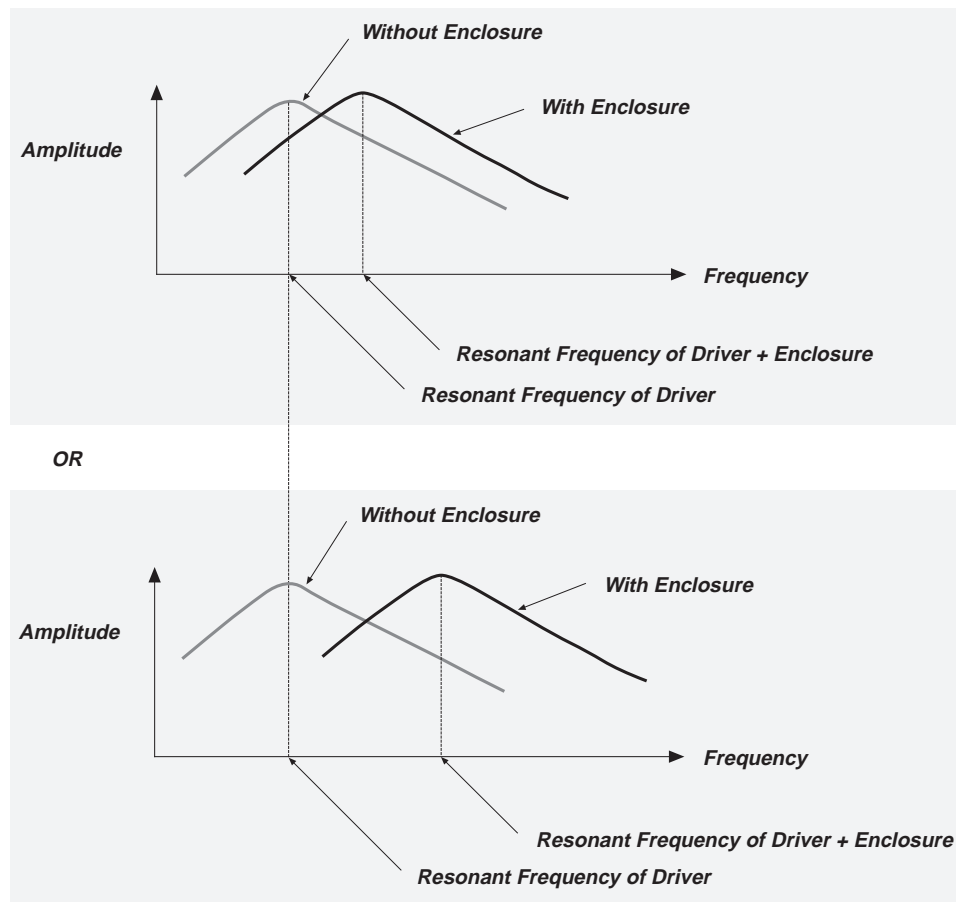

Figure 4.27: Effect of enclosure on frequency response of speaker.

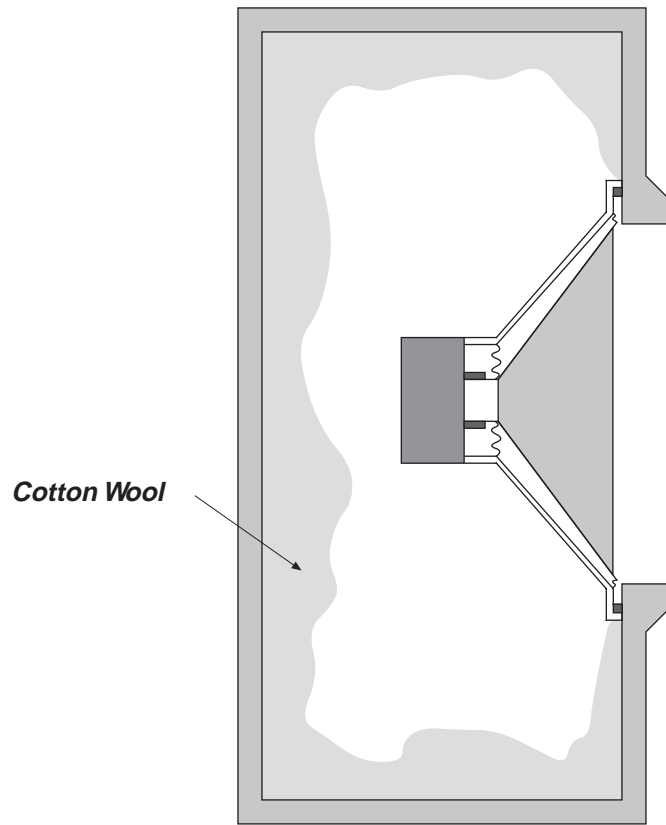

Figure 4.28: Reducing standing waves inside speaker enclosure.

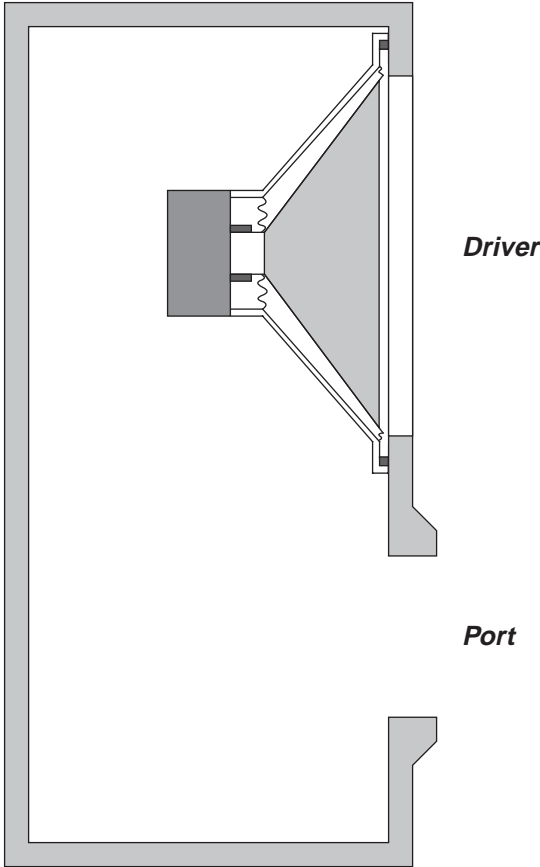

Figure 4.29: Basic bass-reflex enclosure.

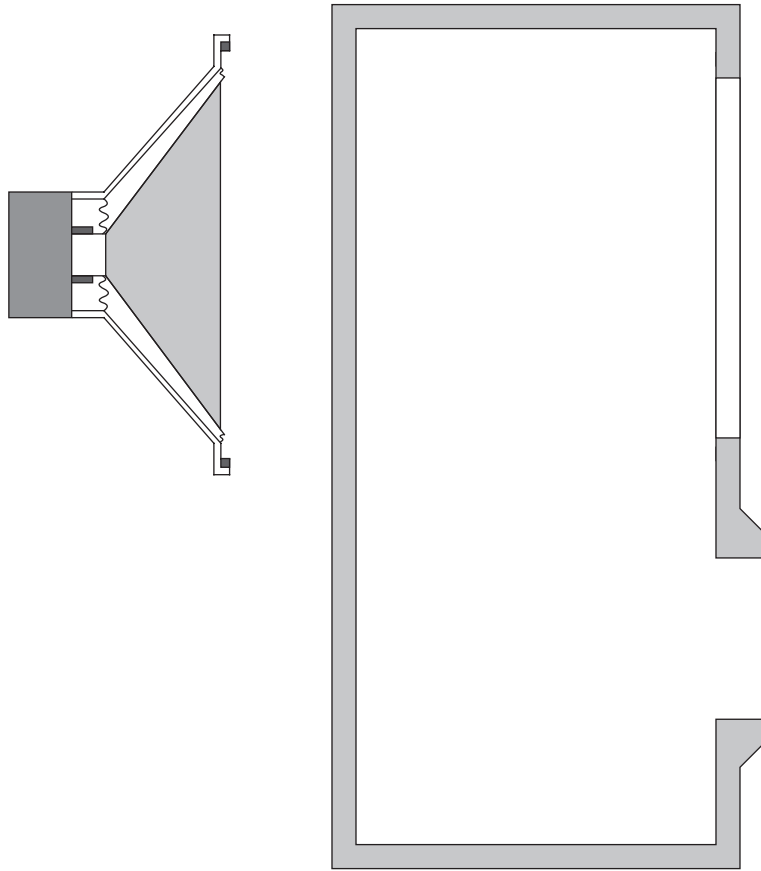

Figure 4.30: Oscillating components of bass-reflex speaker.

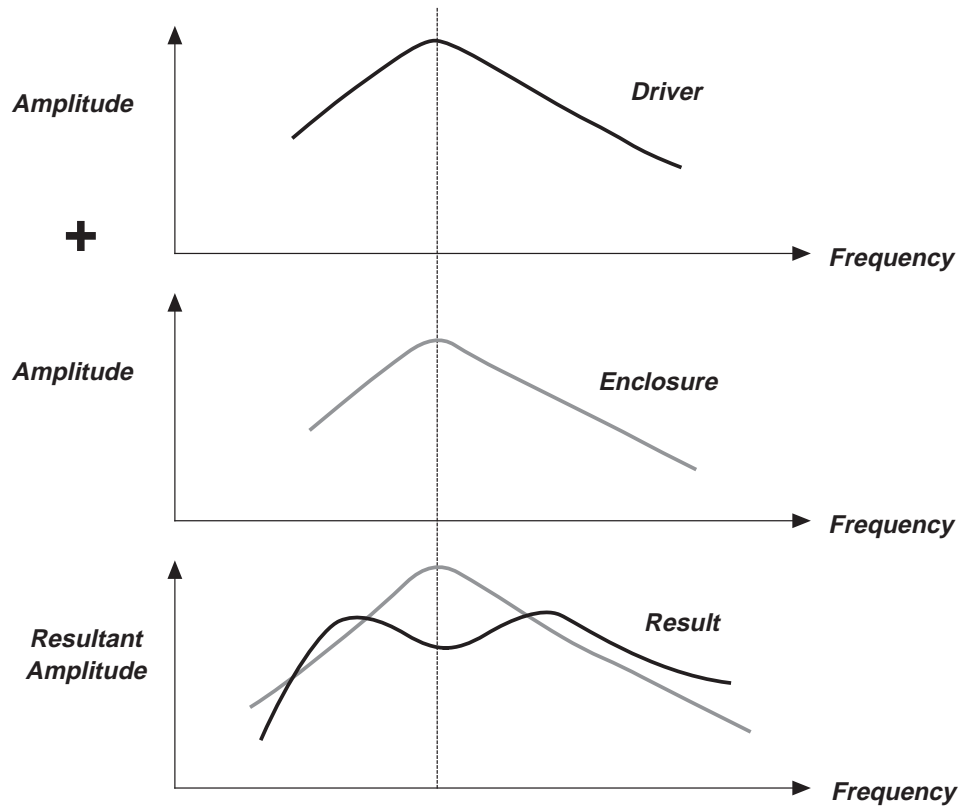

Figure 4.31: Splitting of original resonance into two new resonances in bass-reflex system.

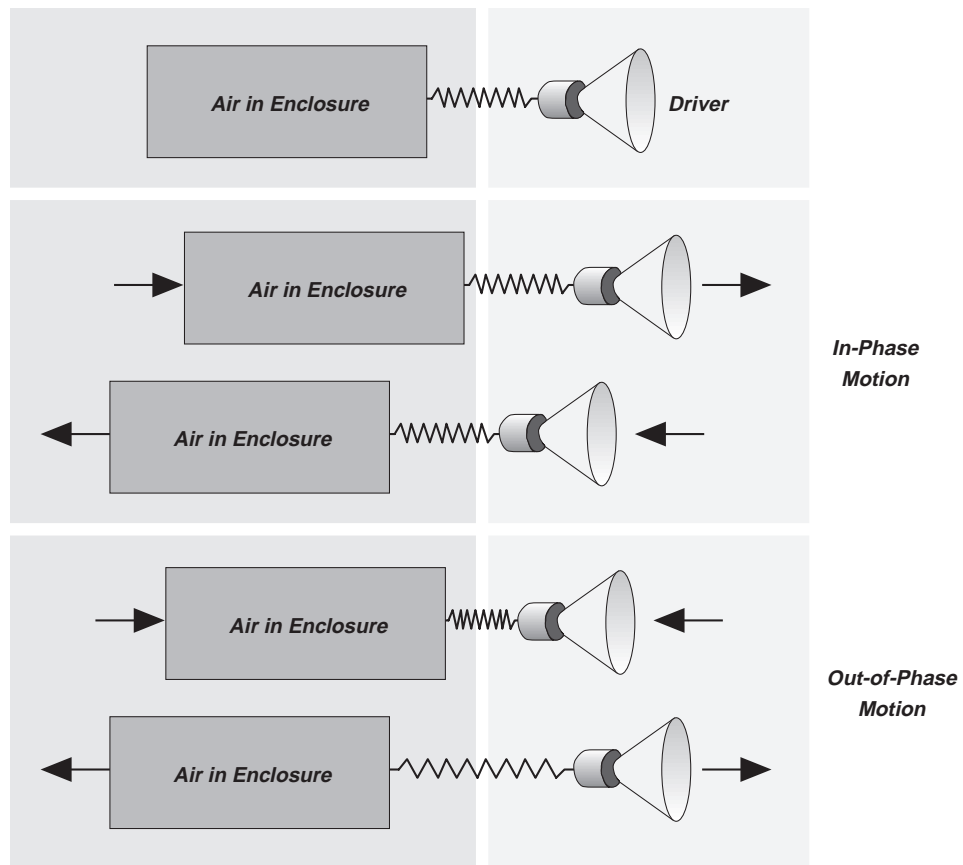

Figure 4.32: Resonant behavior, in-phase and out-of-phase, motion of strongly coupled components of bass-reflex system.

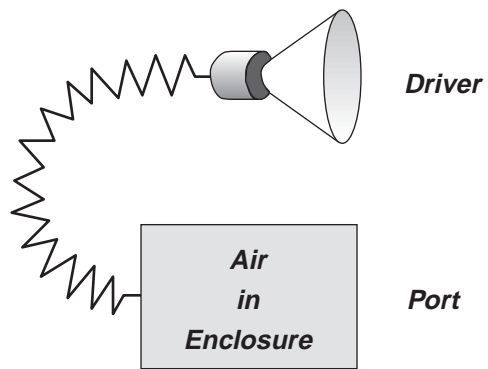

Figure 4.33: Coupled components of a bass-reflex speaker.

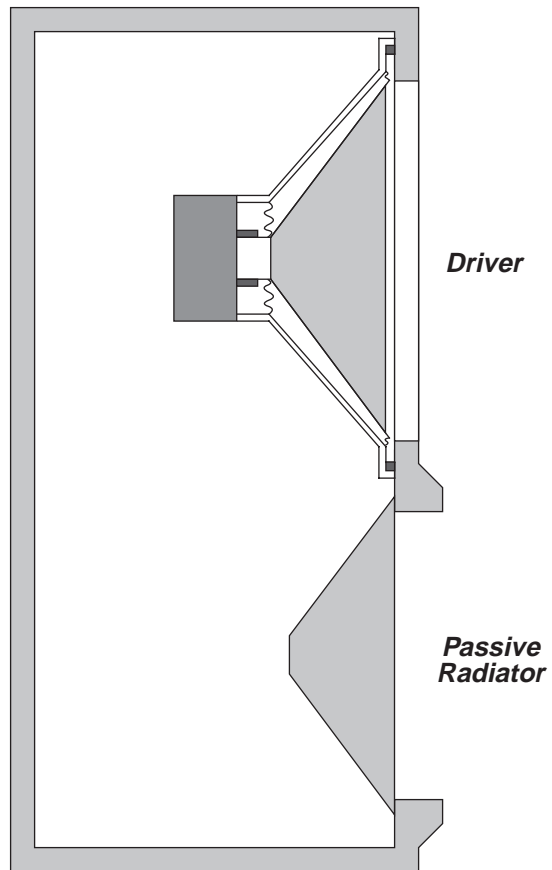

Figure 4.34: Bass-reflex speaker using a passive radiator over the port.

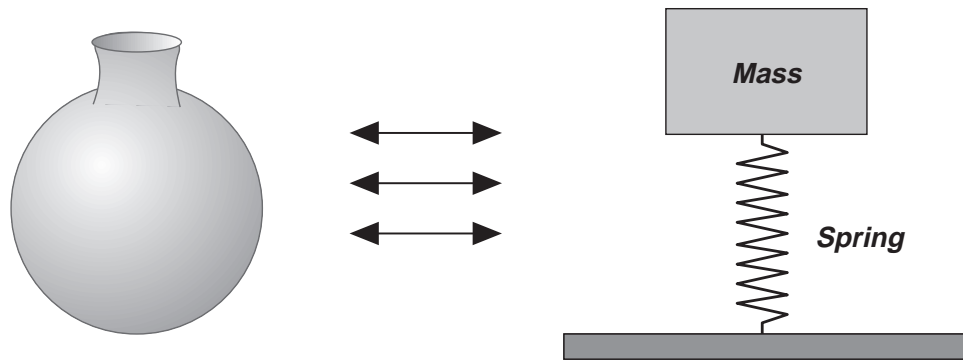

Figure 4.35: Helmholtz resonator behaves like mass-spring system.

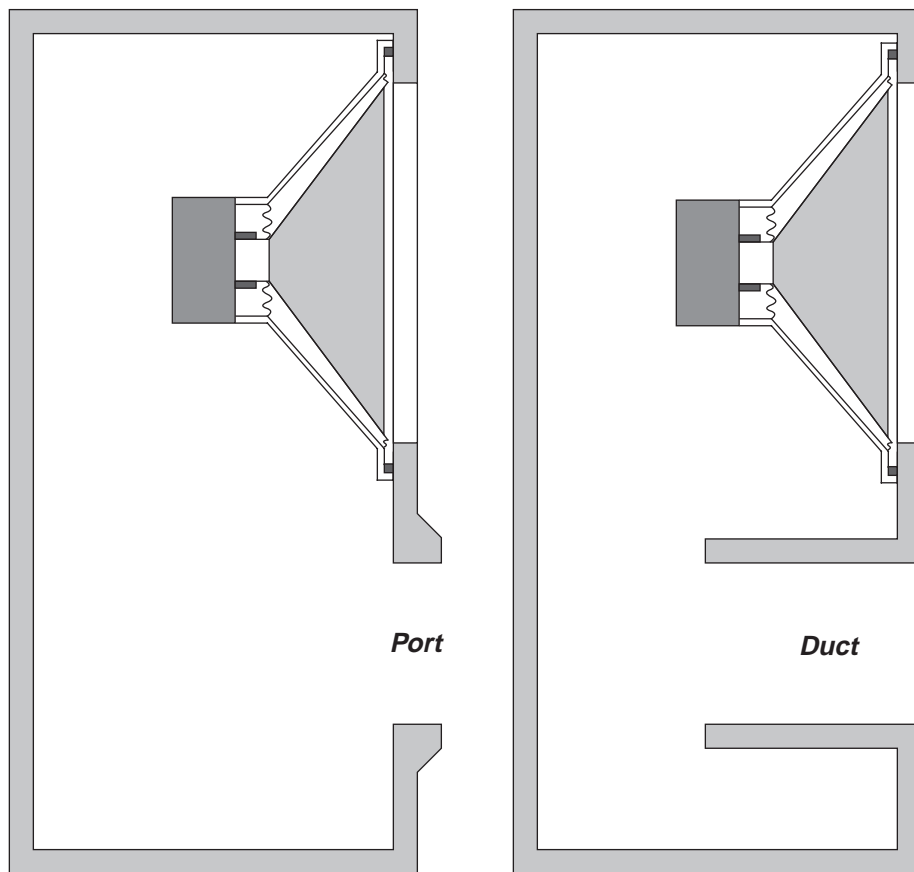

Figure 4.36: Bass-reflex speaker using a port or a duct.

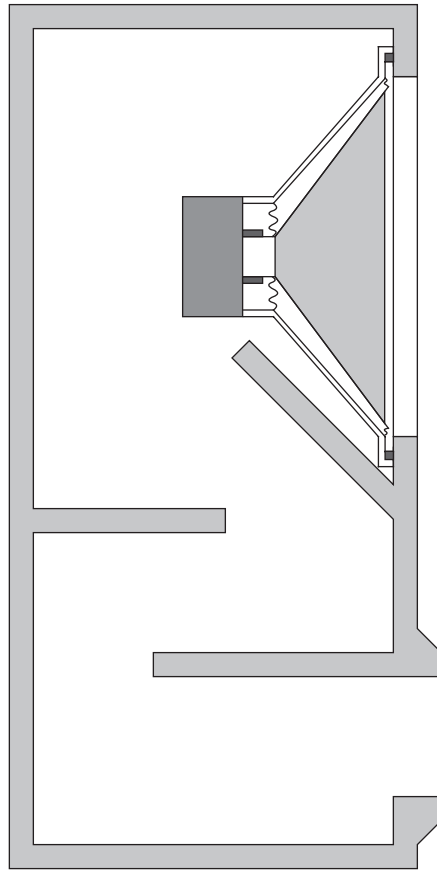

Figure 4.37: Acoustic labyrinth enclosure.

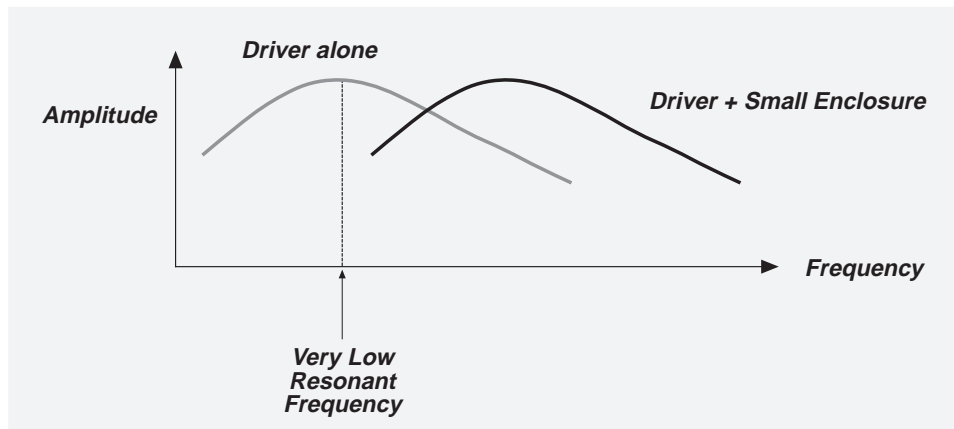

Figure 4.38: Change of frequency response of speaker when a small enclosure is used.

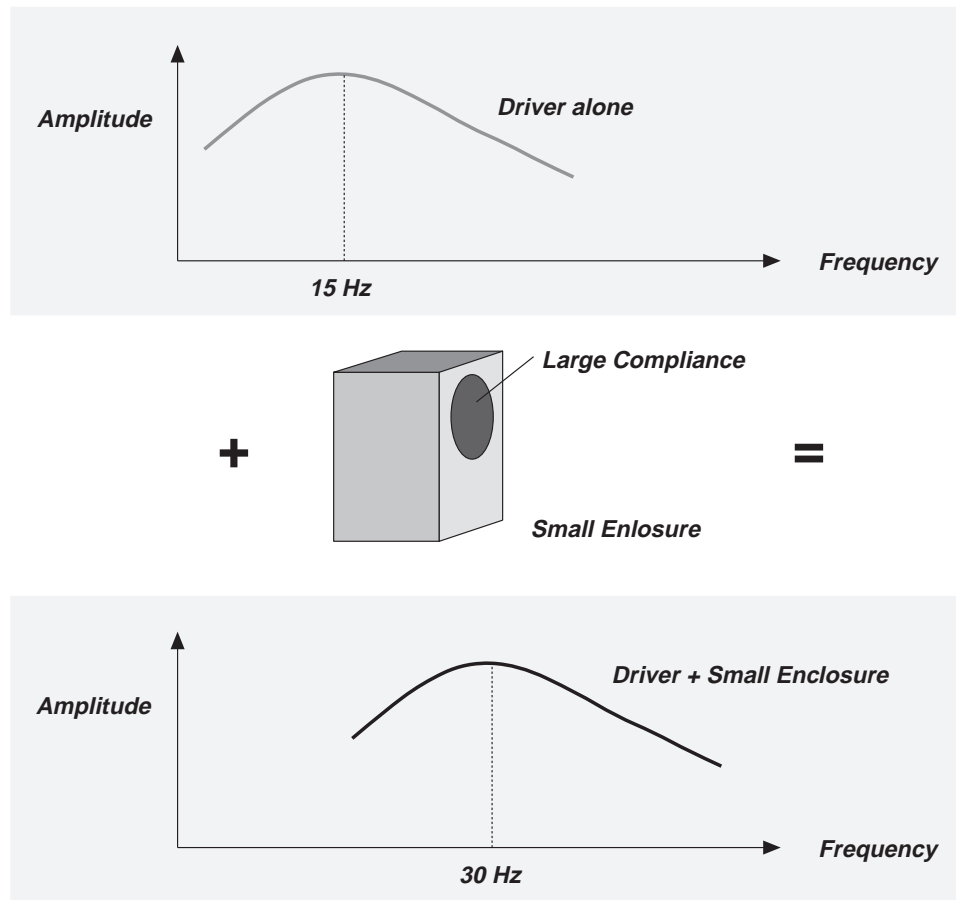

Figure 4.39: Effect of small enclosure on frequency response of driver.

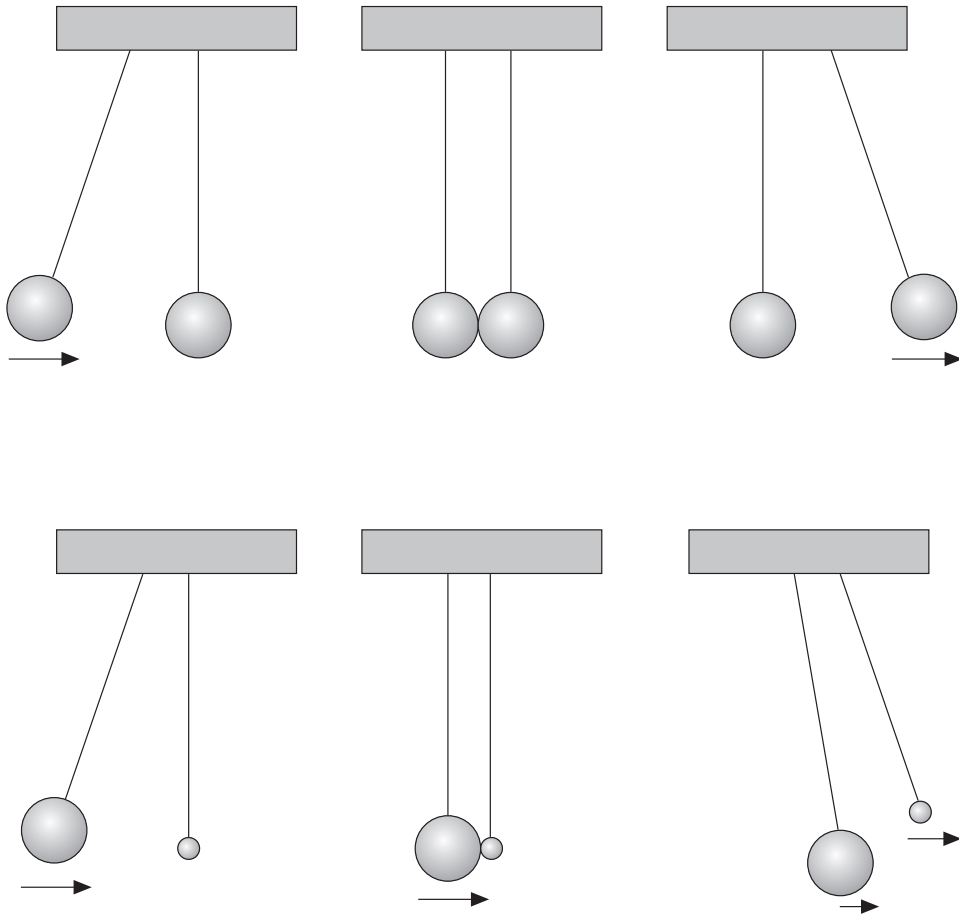

Figure 4.40: Transfer of energy from a bob to one of equal mass, and to one of different mass.

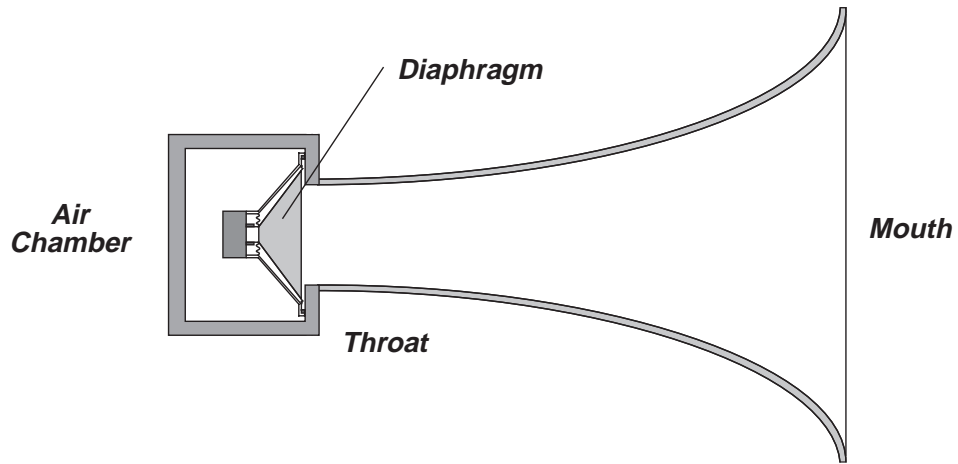

Figure 4.41: A horn for matching vibrations of a light diaphragm to a large volume of air.

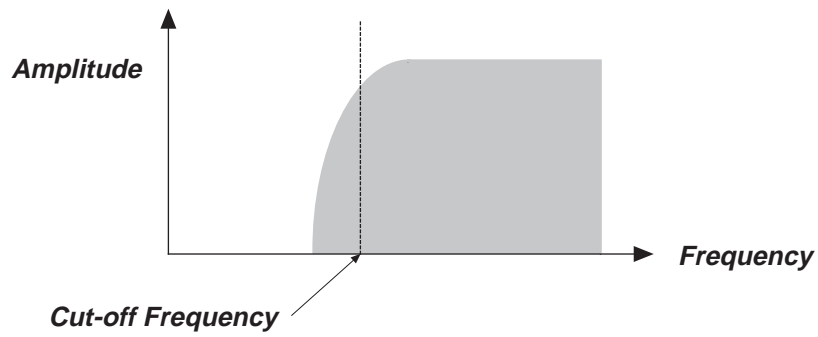

Figure 4.42: Low frequency response of a horn.

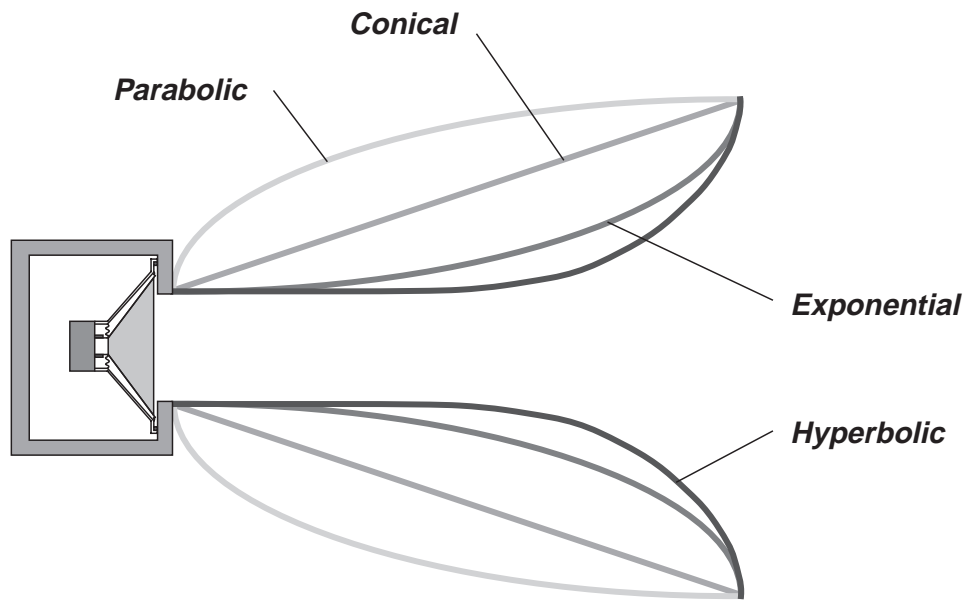

Figure 4.43: Some common horn shapes.

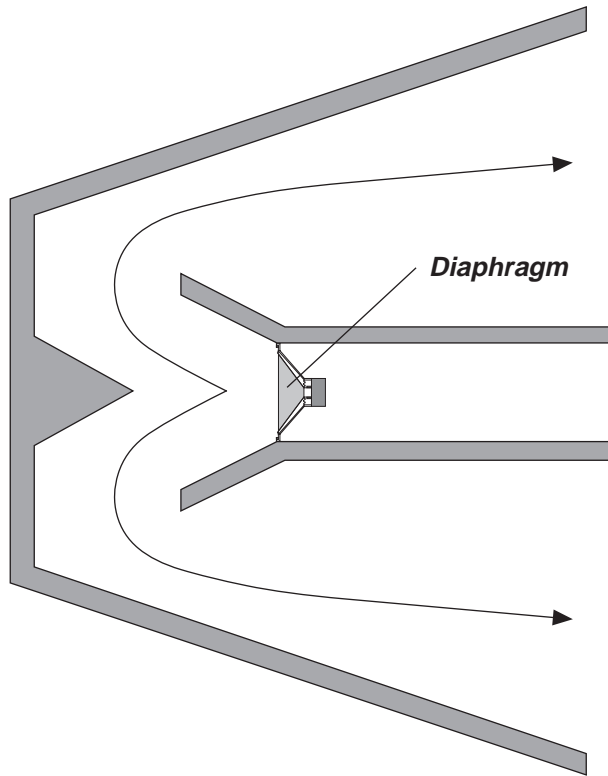

Figure 4.44: Folded horn.

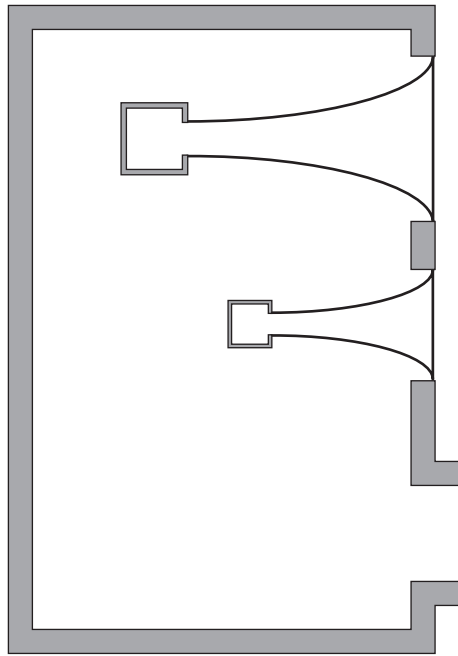

Figure 4.45: Two-way horn loudspeaker with bass-reflex enclosure.

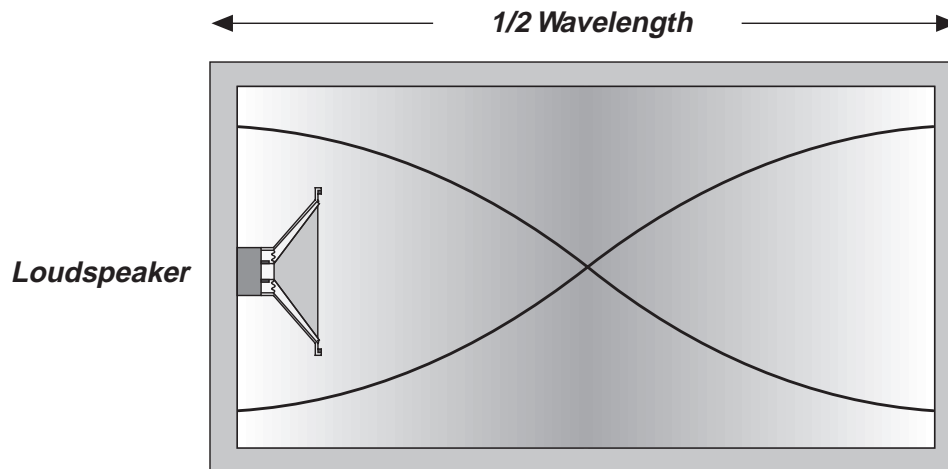

Figure 4.46: Standing wave set up in a room with maxima and minima in sound pressure.

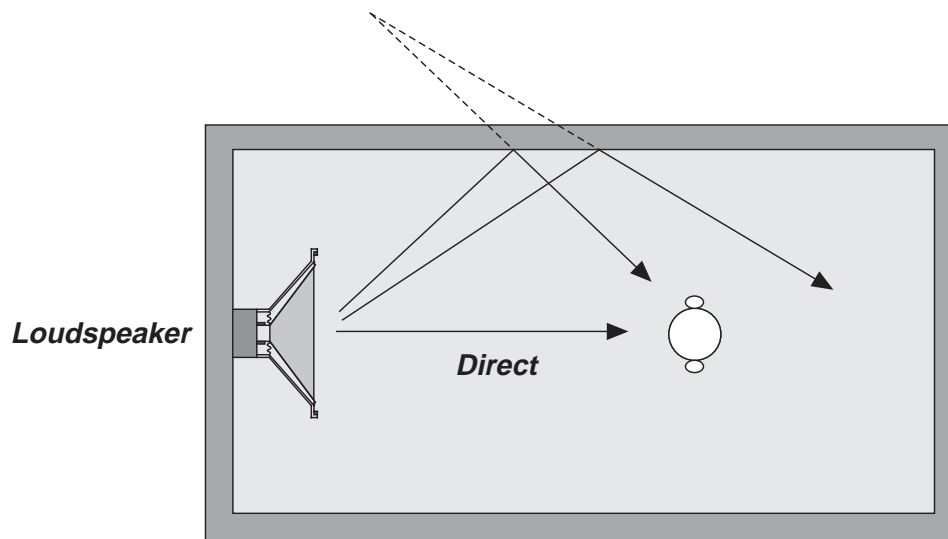

Figure 4.47: Reflected waves by a wall appear to come from behind the wall since it acts like a mirror.

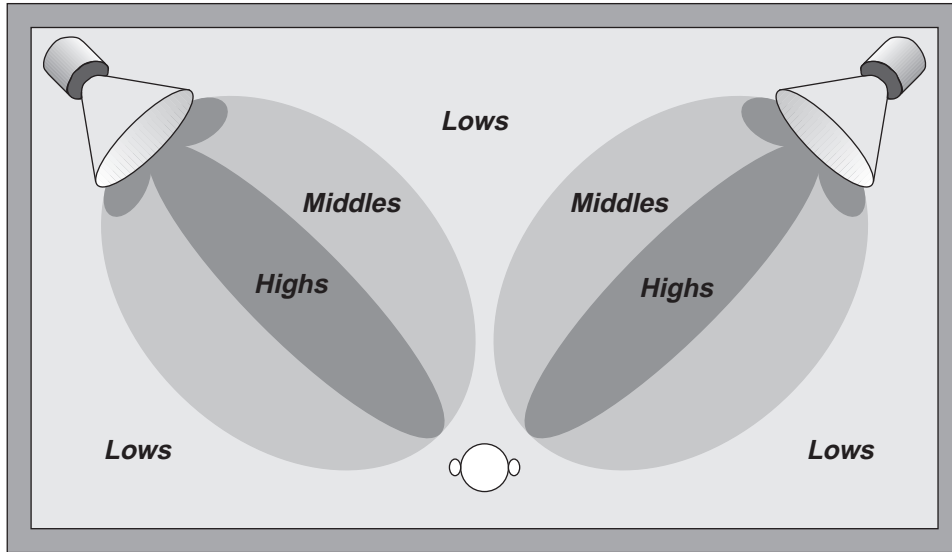

Figure 4.48: Stereo coverage in a room.

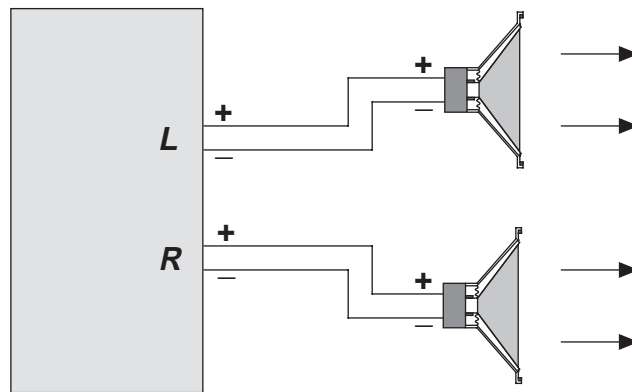

Figure 4.49: Speaker phasing: speakers are in phase.

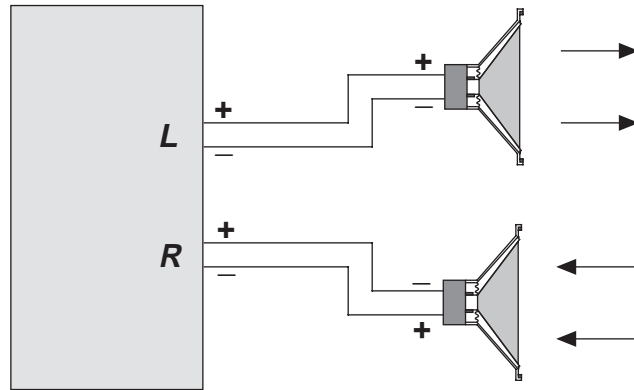

Figure 4.50: Speaker phasing: speakers are out of phase.

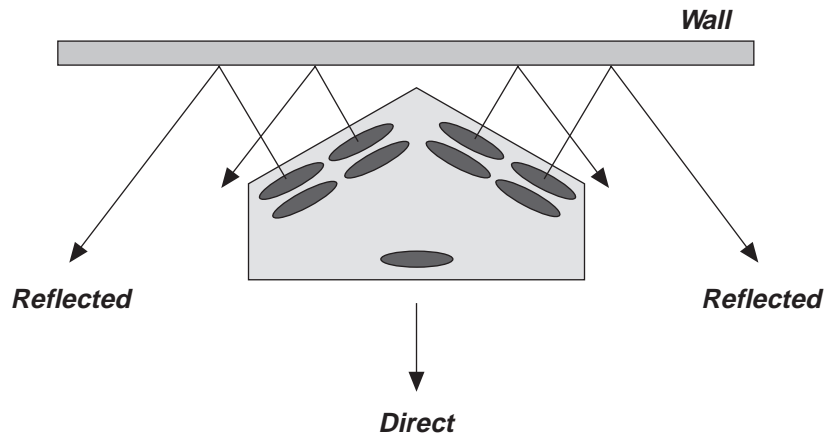

Figure 4.51: Geometry of a Bose 901 speaker.

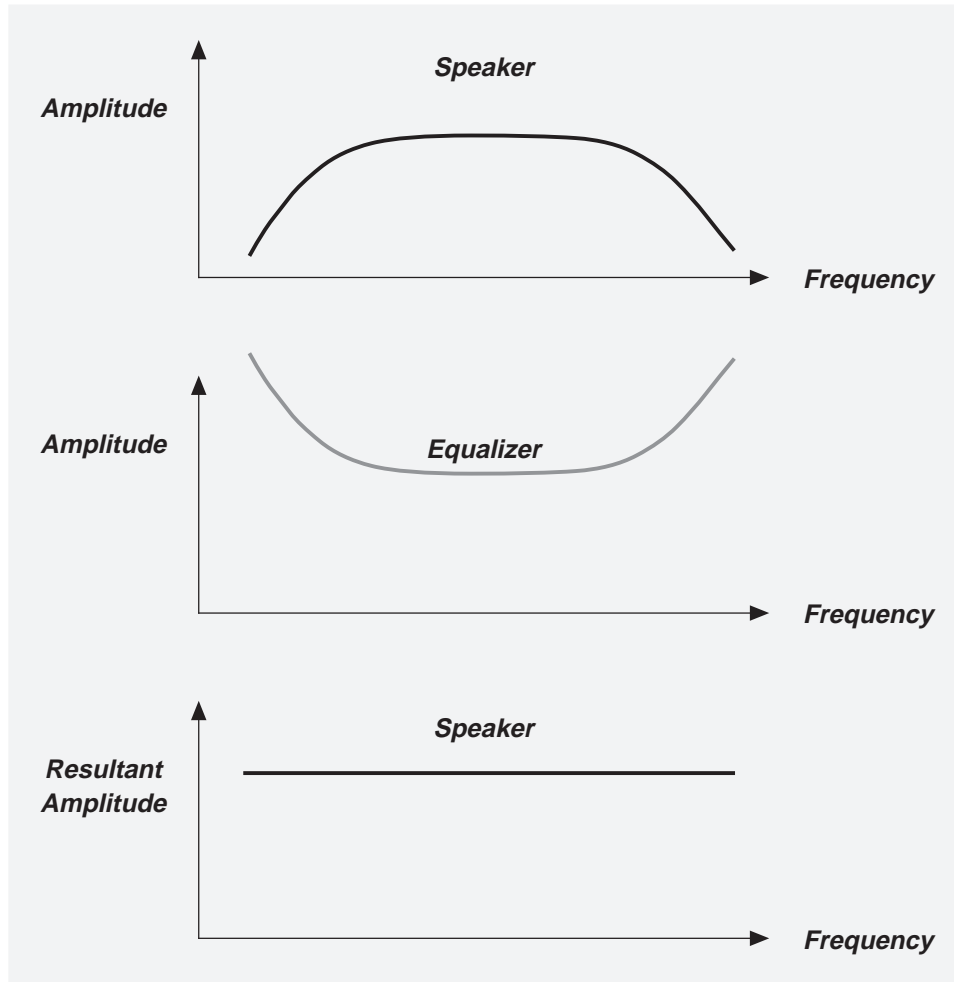

Figure 4.52: Effect of equalizer on frequency response of Bose speakers.

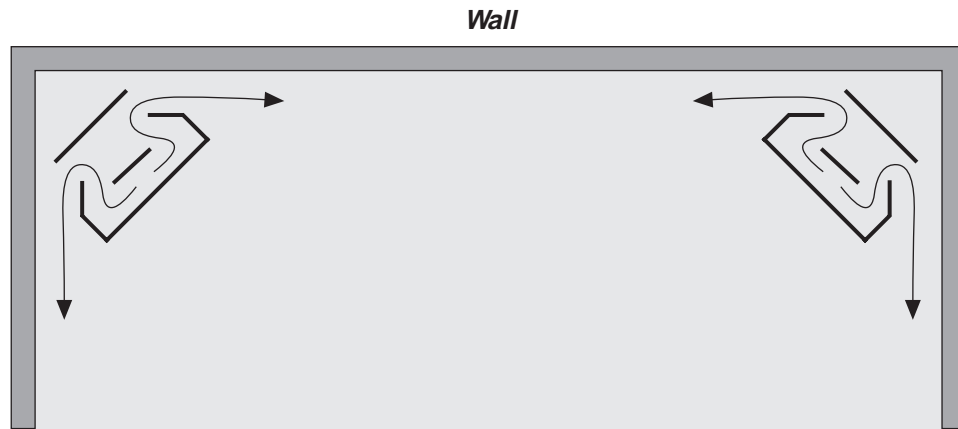

Figure 4.53: Bass horn in Klipsch horn speaker.

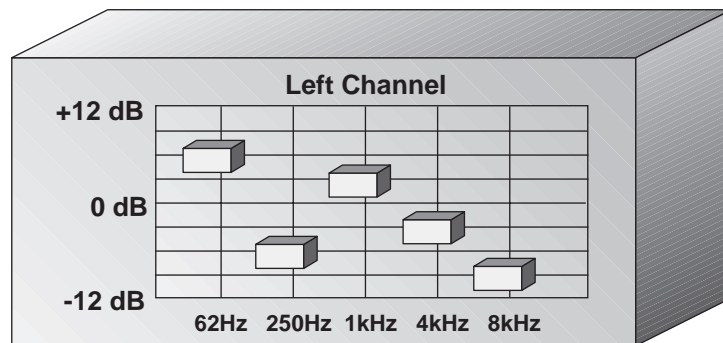

Figure 4.54: Graphic equalizer.

Chapter 5

Electricity

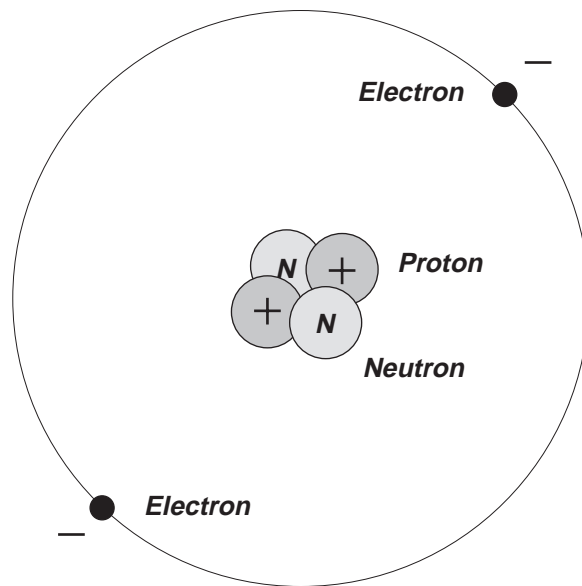

Figure 5.1: Example of an atom: a Helium atom.

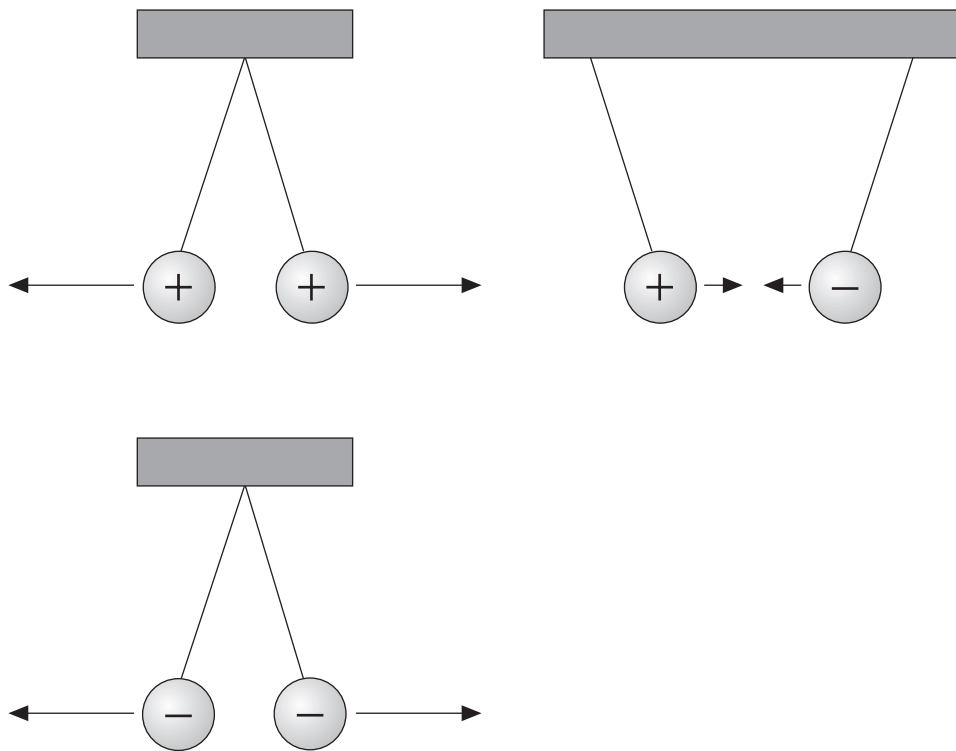

Figure 5.2: Forces between charged objects; like charges repel and unlike charges attract.

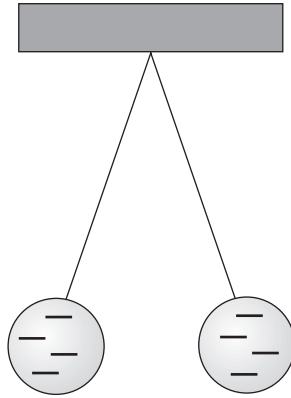

Figure 5.3: Charged ping-pong balls repelling each other.

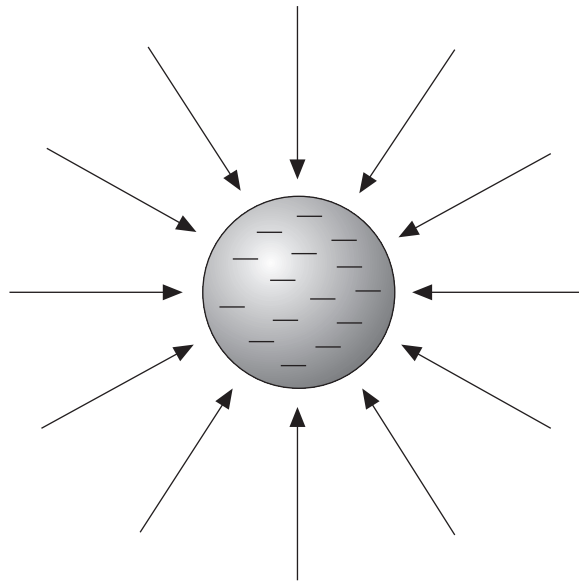

Figure 5.4: Electric field produced by a charged object.

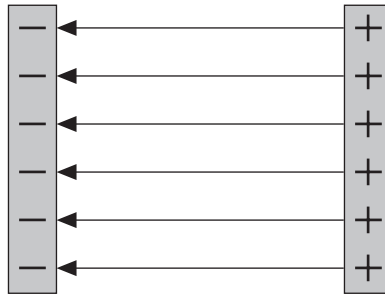

Figure 5.5: Electric field between two charged plates.

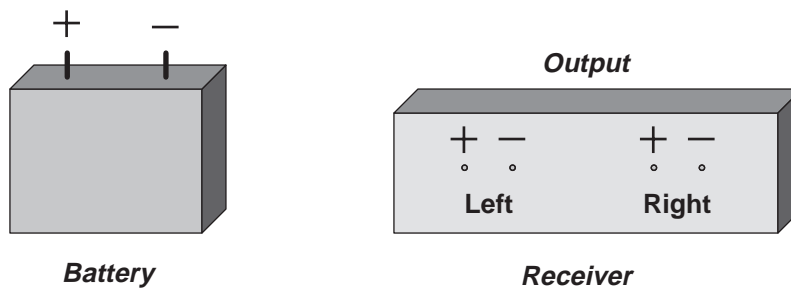

Figure 5.6: Examples of voltage sources: a battery, the output of a receiver.

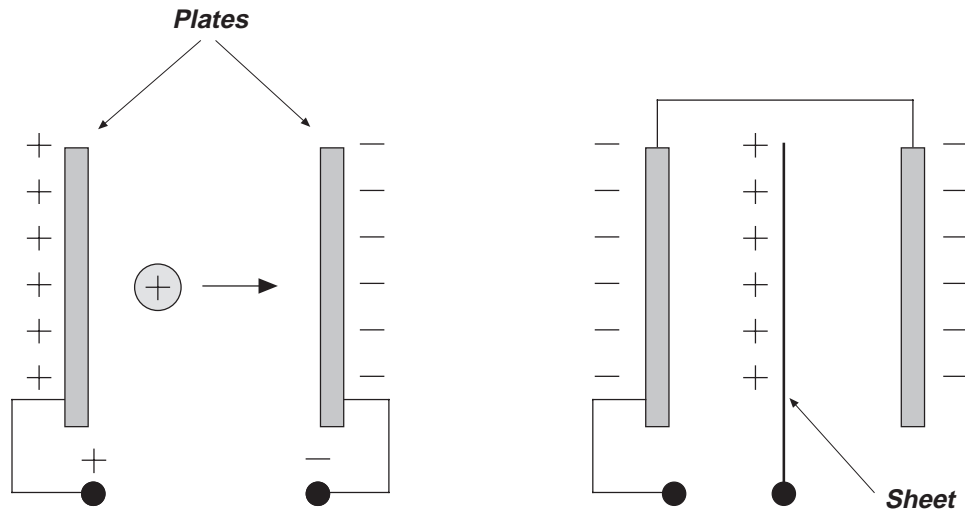

Figure 5.7: Electrostatic speaker: basic principle and actual speaker.

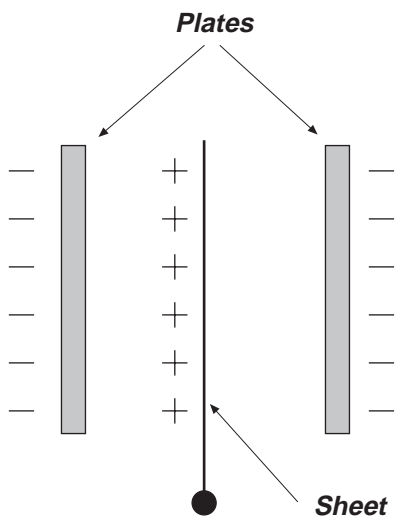

Figure 5.8: Simplified version of an electrostatic speaker at equilibrium.

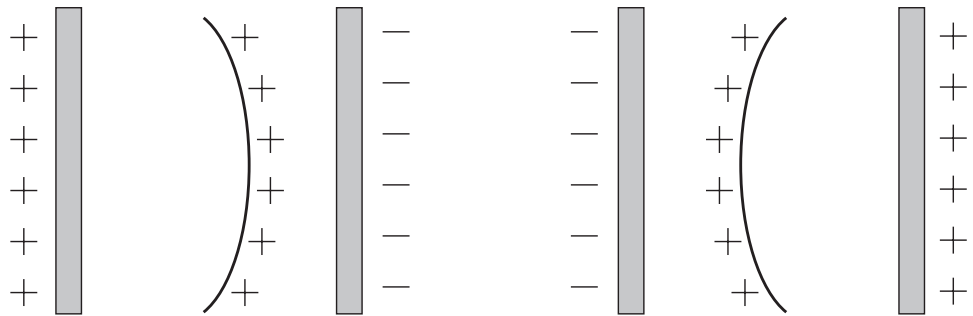

Figure 5.9: Push-pull action by two plates on charged sheet.

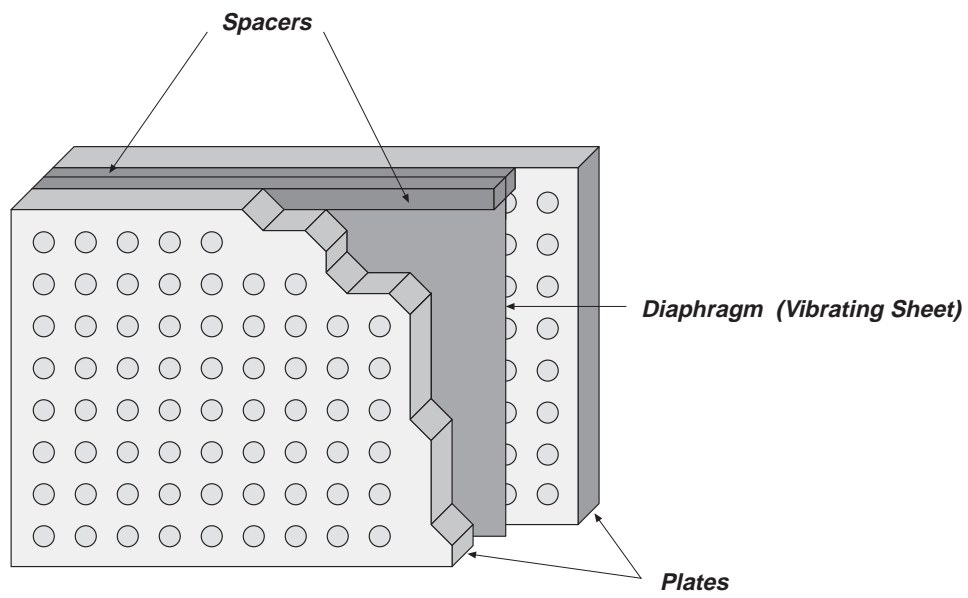

Figure 5.10: An electrostatic speaker.

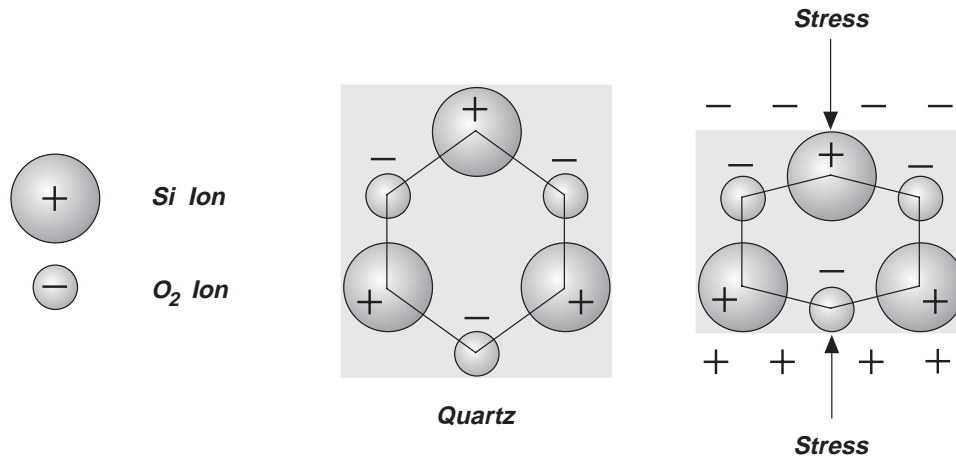

Figure 5.11: Some crystals under pressure produce positive and negative charges on surface.

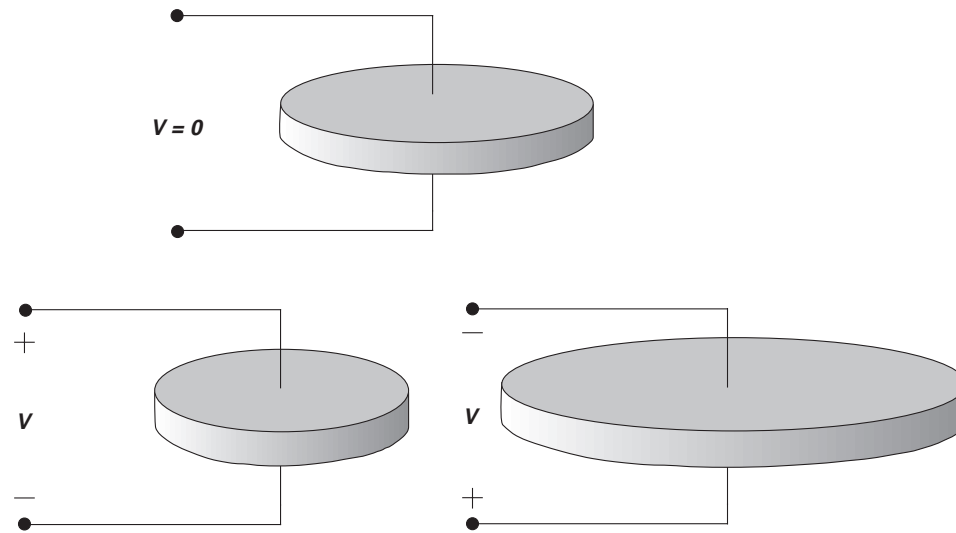

Figure 5.12: Dimensional changes of a piezoelectric ceramic when a voltage is applied.

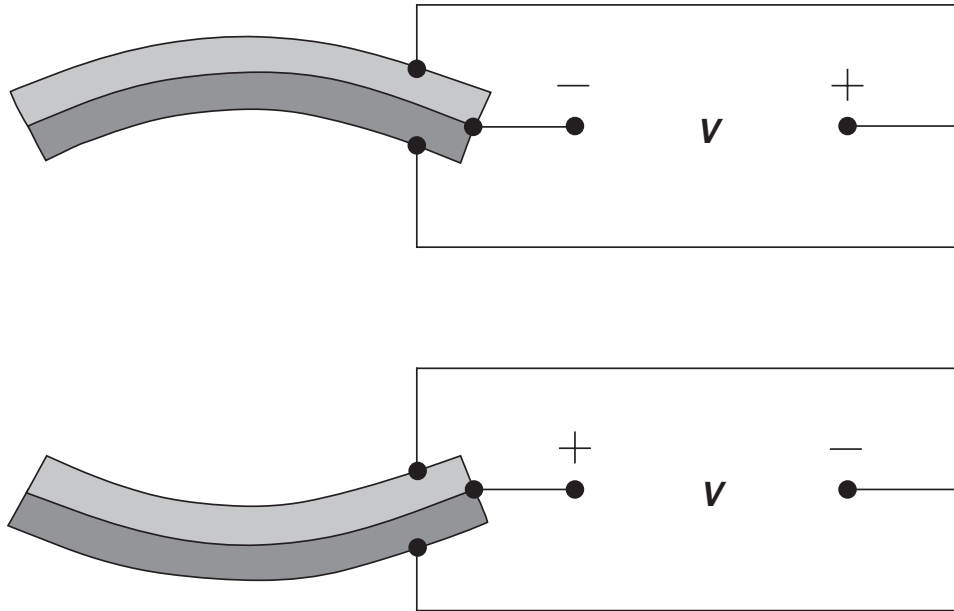

Figure 5.13: Bending action of a double piezoelectric driver.

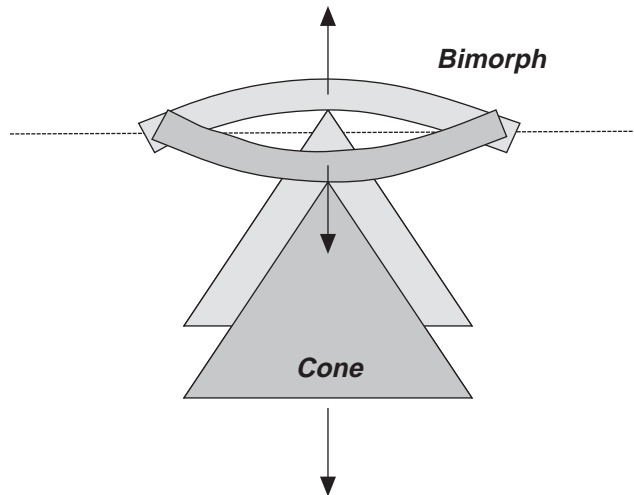

Figure 5.14: Pumping action of cone caused by bending of bimorph.

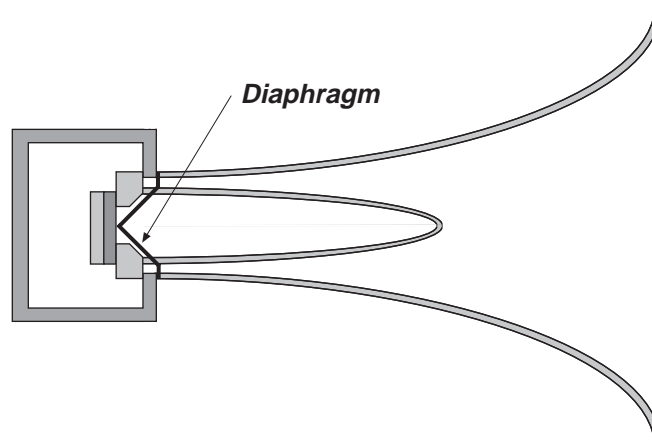

Figure 5.15: Typical piezo horn.

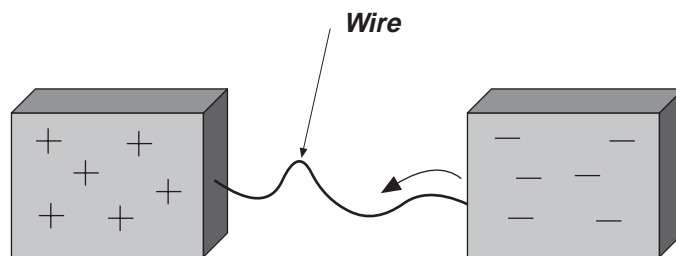

Figure 5.16: Wire connected between two charged objects allows charges to be transferred.

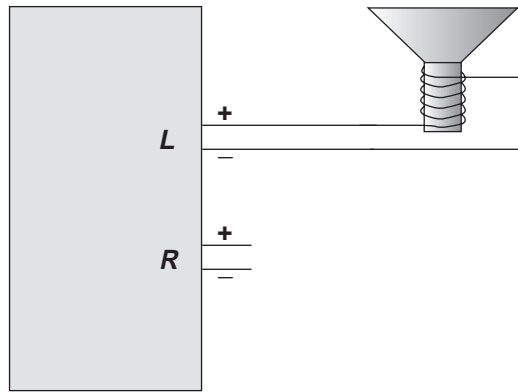

Figure 5.17: Flow of electric current from amplifier to speaker.

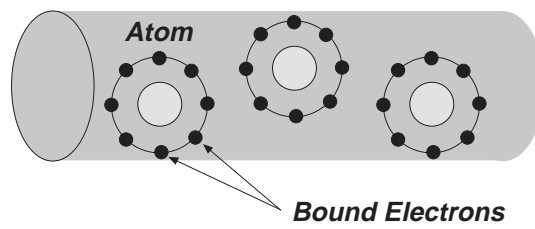

Figure 5.18: Solid with atoms where electrons are tightly bound and which does not conduct electricity under normal circumstances.

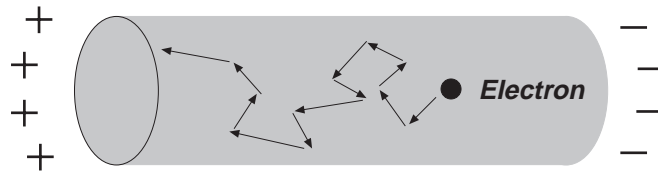

Figure 5.19: Motion of one electron in a conductor in the presence of an electric field. Changes of direction are due to scattering.

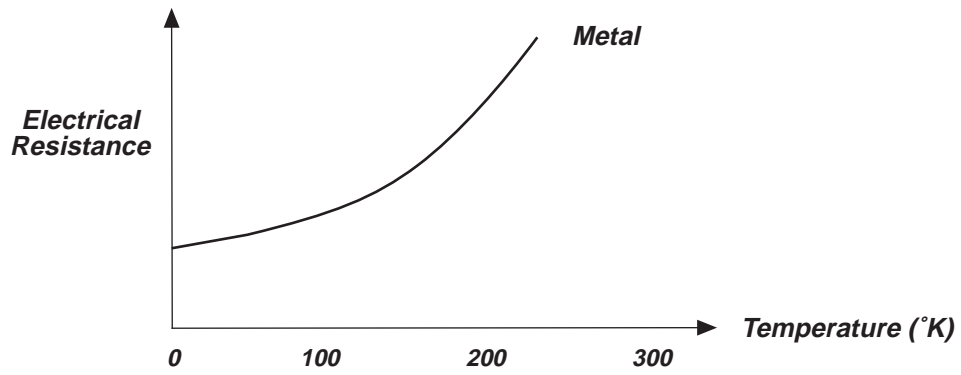

Figure 5.20: Temperature dependence of the electrical resistance in a conductor.

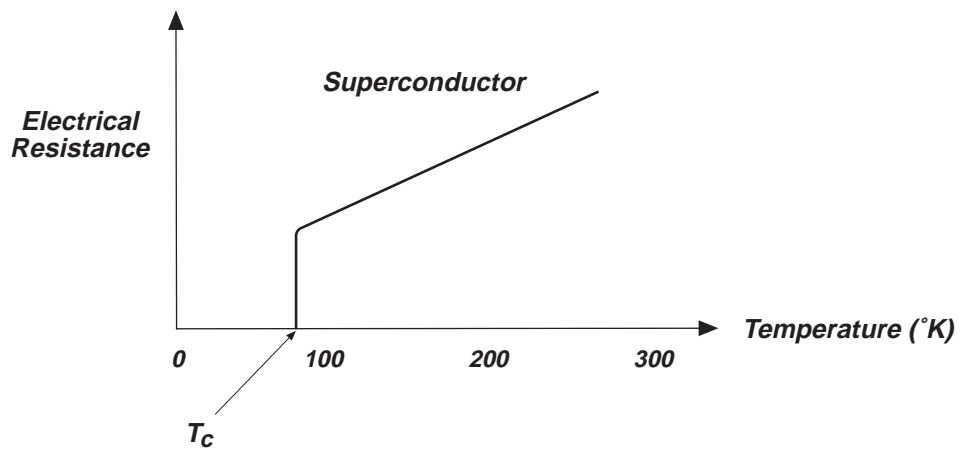

Figure 5.21: Superconductivity at T_c below which the resistance is zero.

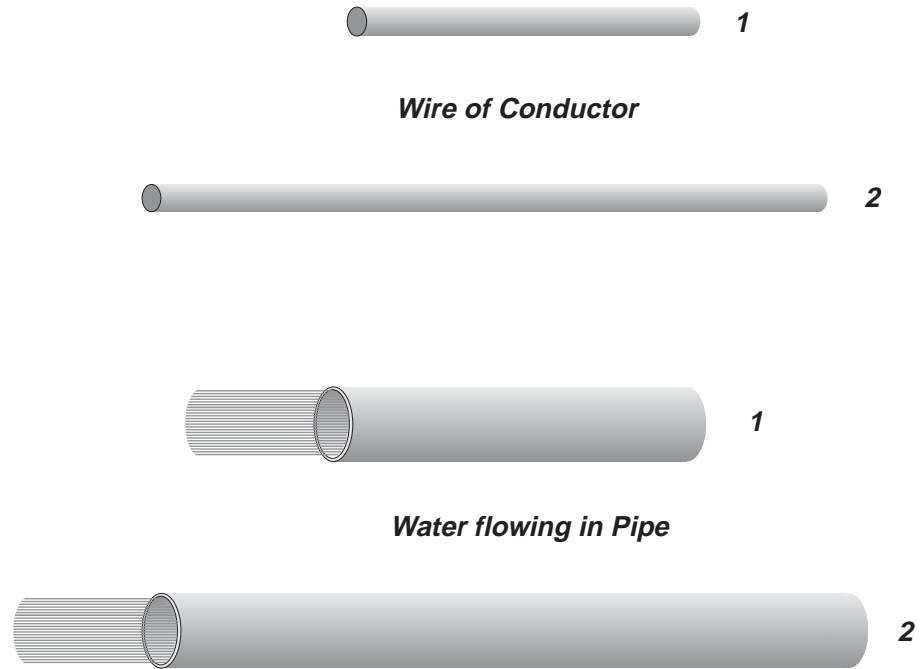

Figure 5.22: The resistance to current or to water flow increases as the length of a conductor or pipe increases. Resistance of 2 is double that of 1.

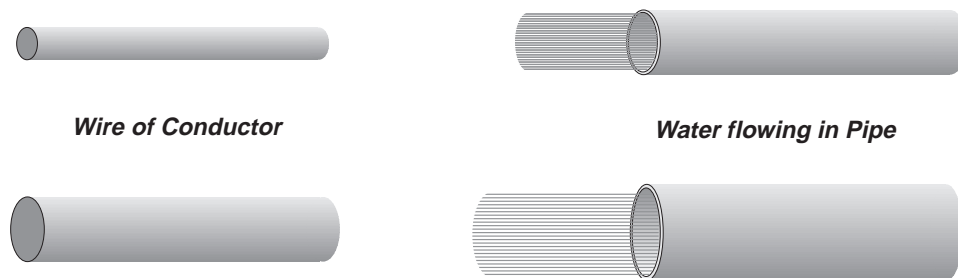

Figure 5.23: By increasing the cross-sectional area of a conductor, resistance to current or water flow decreases.

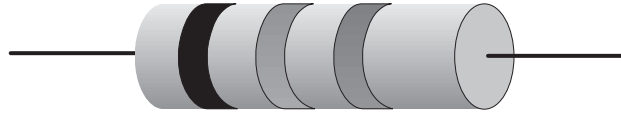

Figure 5.24: Resistor with colored bands to specify its resistance value.

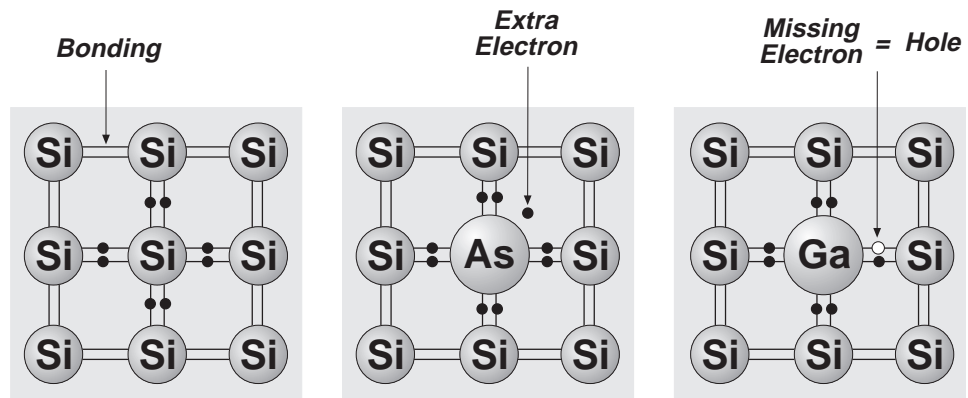

Figure 5.25: Pure silicon, silicon doped with arsenic, and silicon doped with gallium.

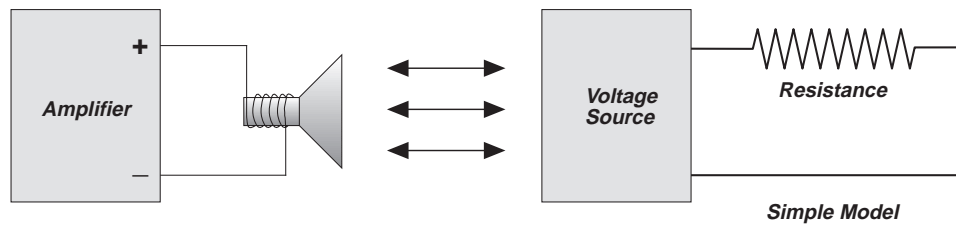

Figure 5.26: Example of simple circuit.

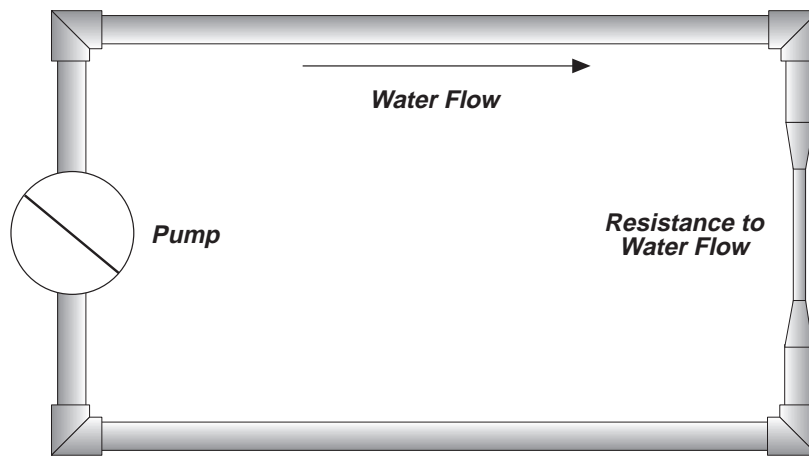

Figure 5.27: Model using water for electric circuit.

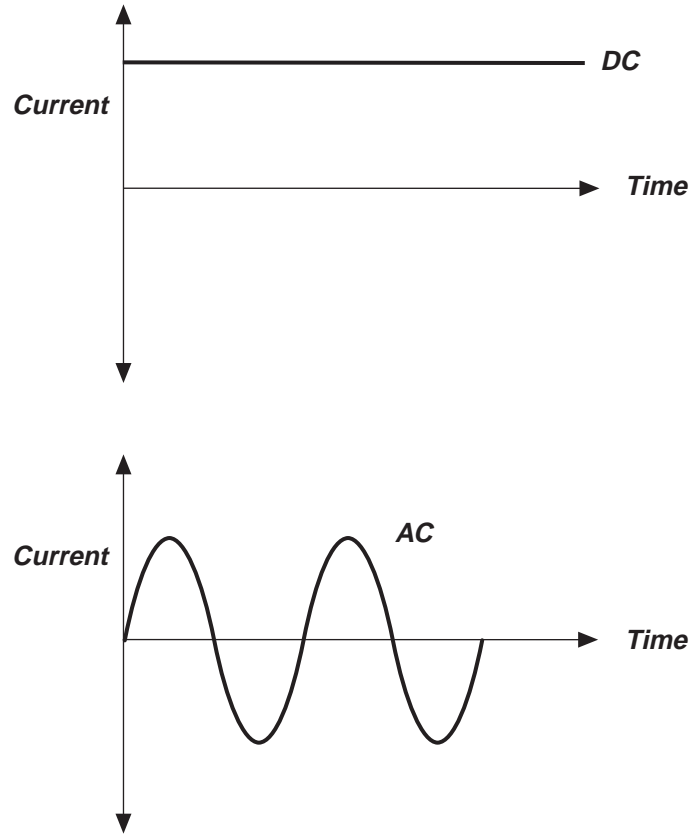

Figure 5.28: Comparison between DC and AC current.

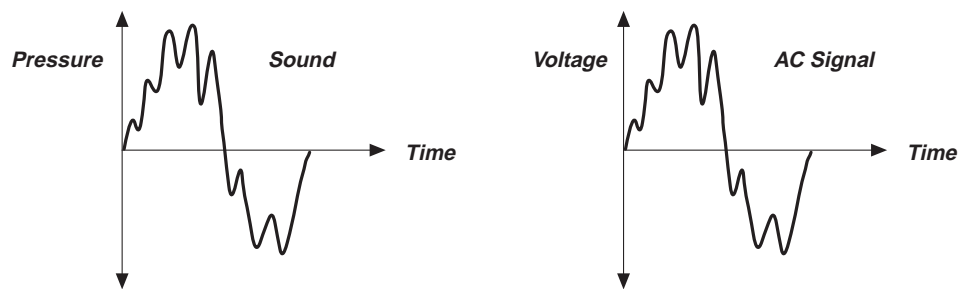

Figure 5.29: Representation of a sound wave by an AC electrical signal.

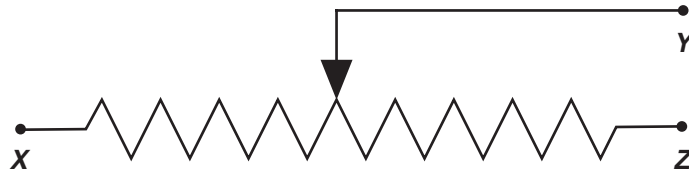

Figure 5.30: Variable resistance between X and Y.

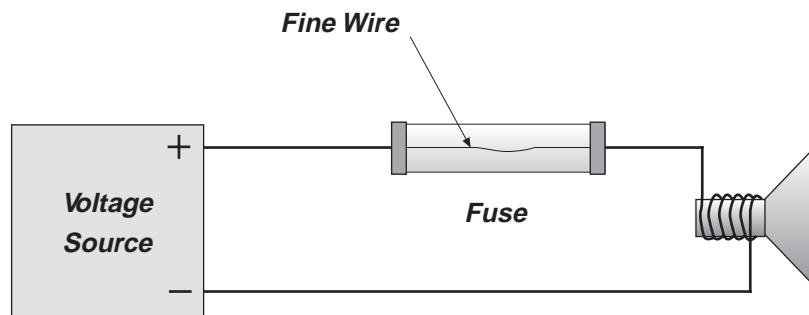

Figure 5.31: Fuse to protect speaker.

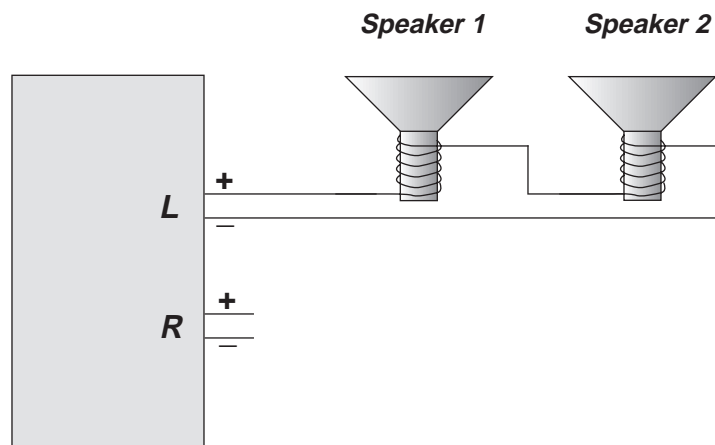

Figure 5.32: Two speakers connected in series to one channel of amplifier.

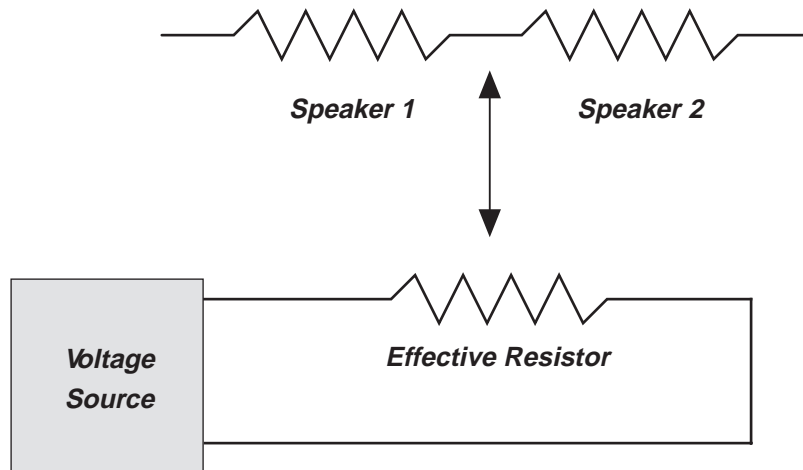

Figure 5.33: Model of series circuit.

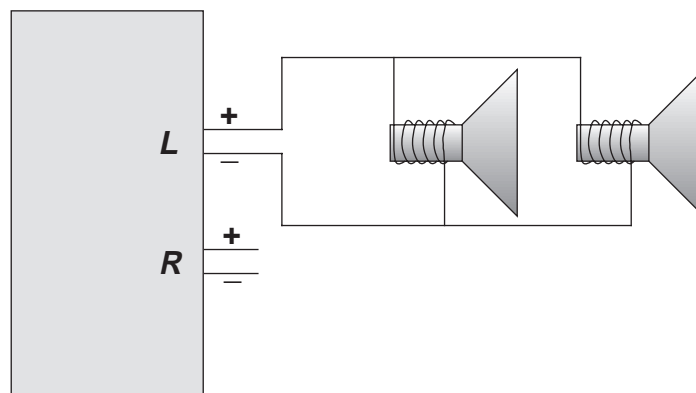

Figure 5.34: Parallel connection of two speakers to an amplifier.

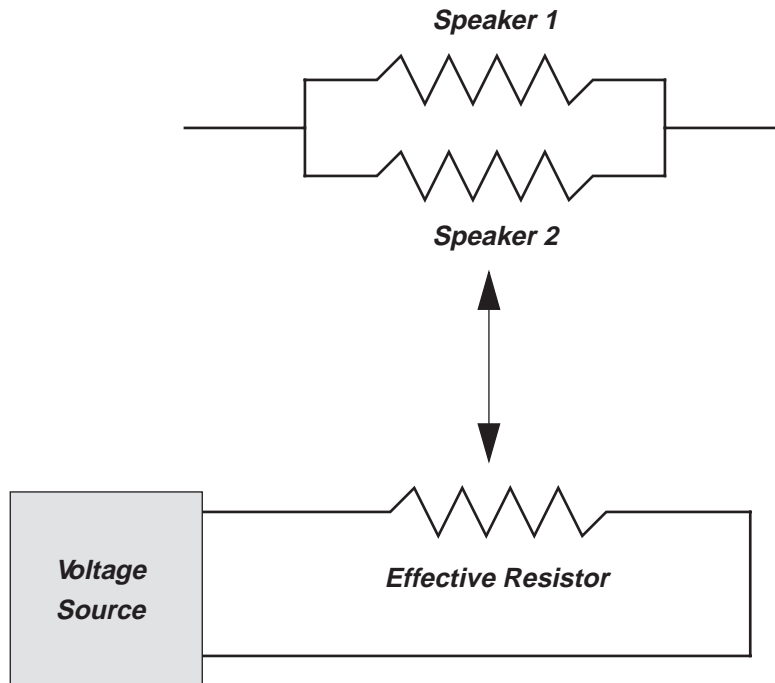

Figure 5.35: Model of parallel connections.

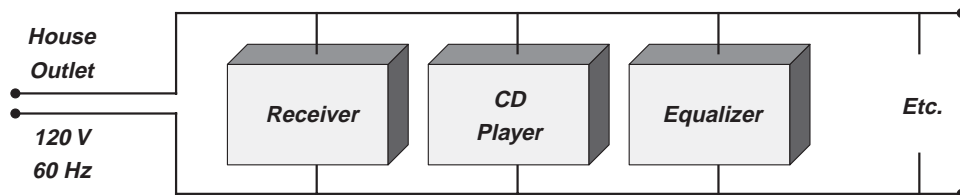

Figure 5.36: Parallel connections of hi-fi components to house electrical outlet.

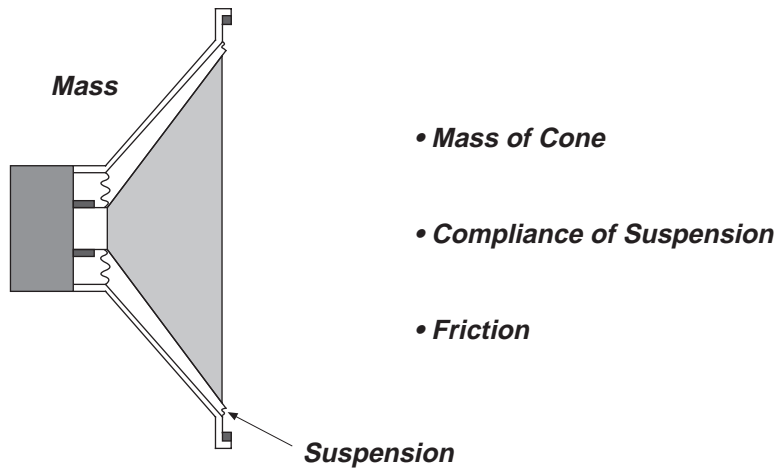

Figure 5.37: Response of cone speaker to a force.

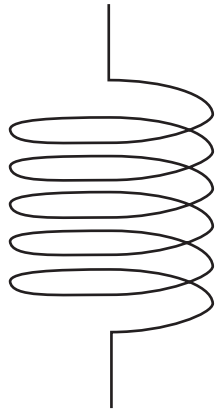

Figure 5.38: Coil used to produce a magnetic field when a current flows through it. It has inductance.

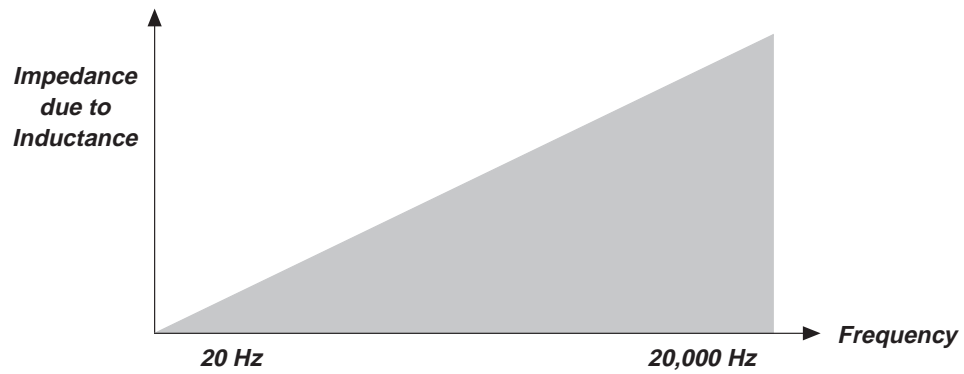

Figure 5.39: Frequency dependence of impedance associated with inductance.

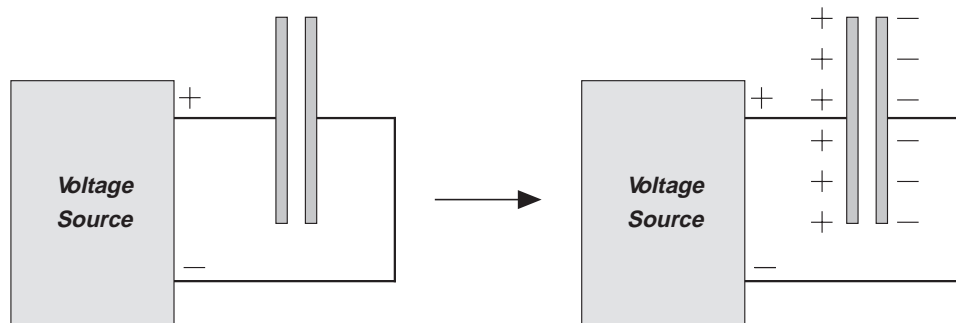

Figure 5.40: Charging of a capacitor.

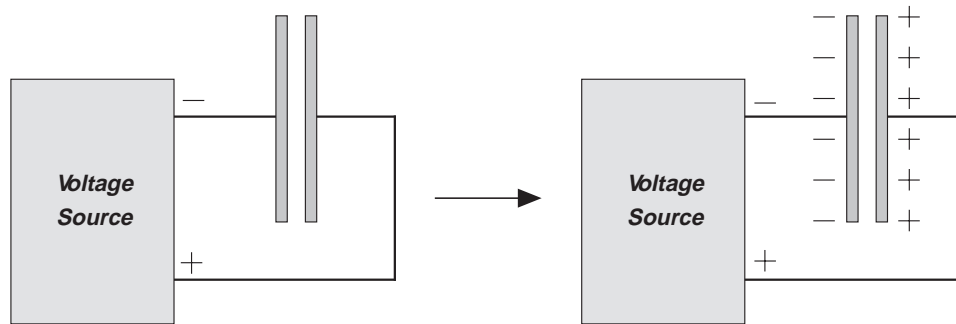

Figure 5.41: Charging of a capacitor when polarity of voltage source is reversed.

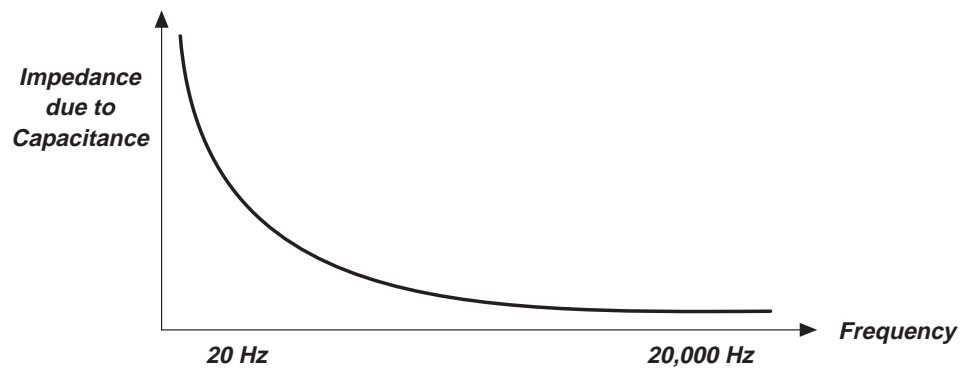

Figure 5.42: Frequency dependence of impedance due to capacitance.

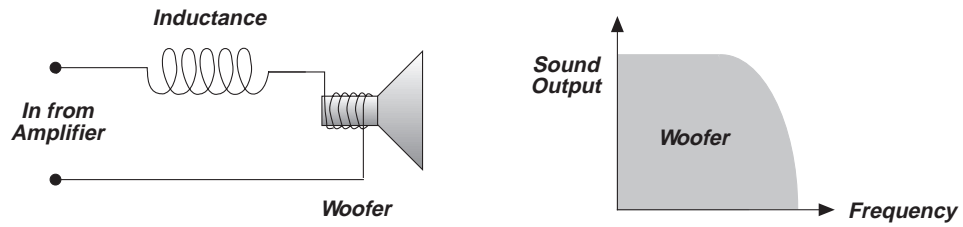

Figure 5.43: Inductance in series with woofer prevents high frequencies from reaching it.

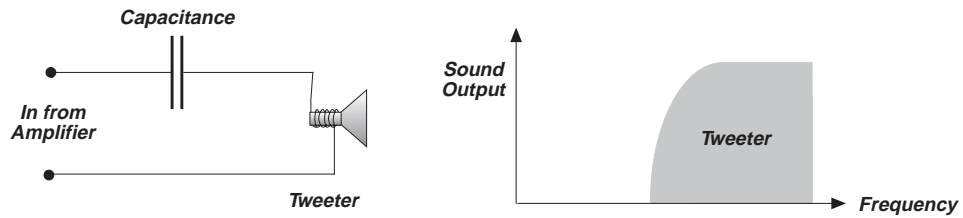

Figure 5.44: Capacitance in series with tweeter. It prevents low frequencies from reaching it.

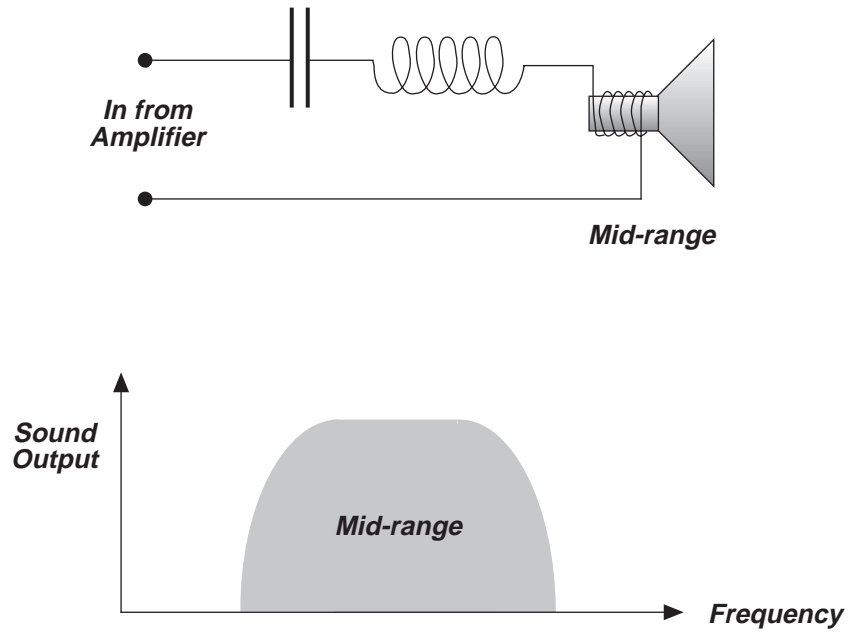

Figure 5.45: Capacitance and inductance in series with mid-range speaker to prevent the high and low frequencies from reaching it.

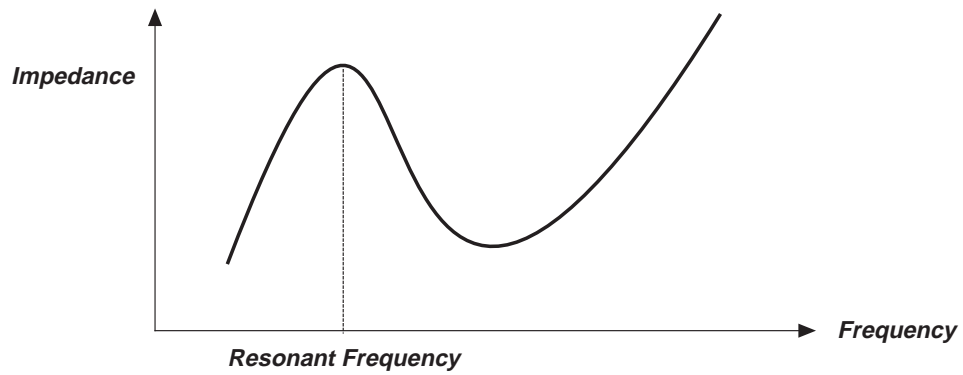

Figure 5.46: Impedance curve of driver.

Chapter 6

Amplifiers

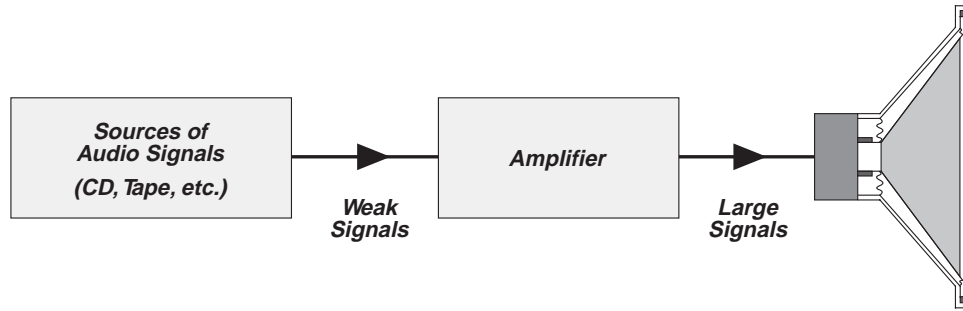

Figure 6.1: Importance of amplifier in hi-fi system.

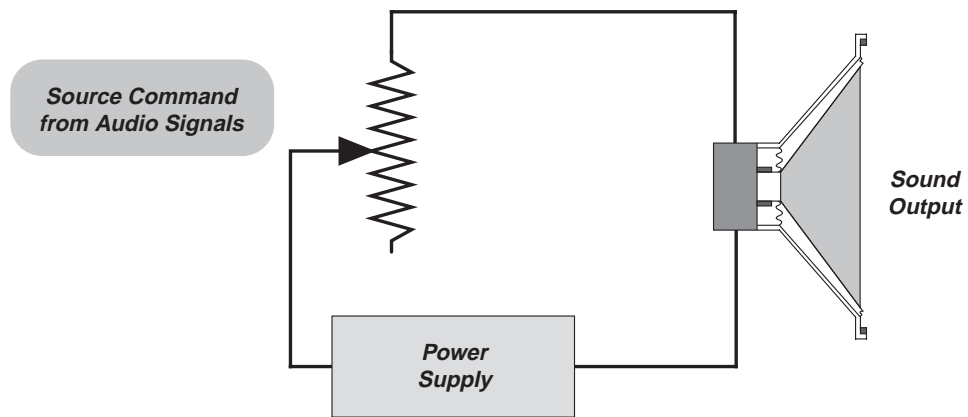

Figure 6.2: Basic amplifier.

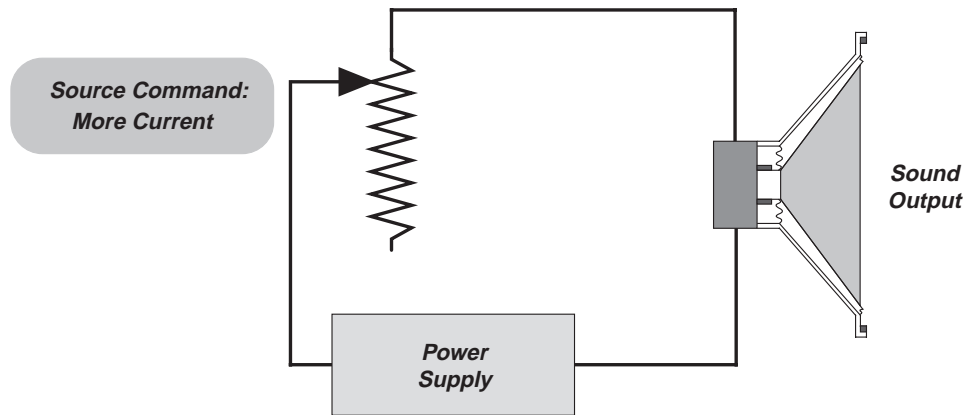

Figure 6.3: Amplifier command for more current.

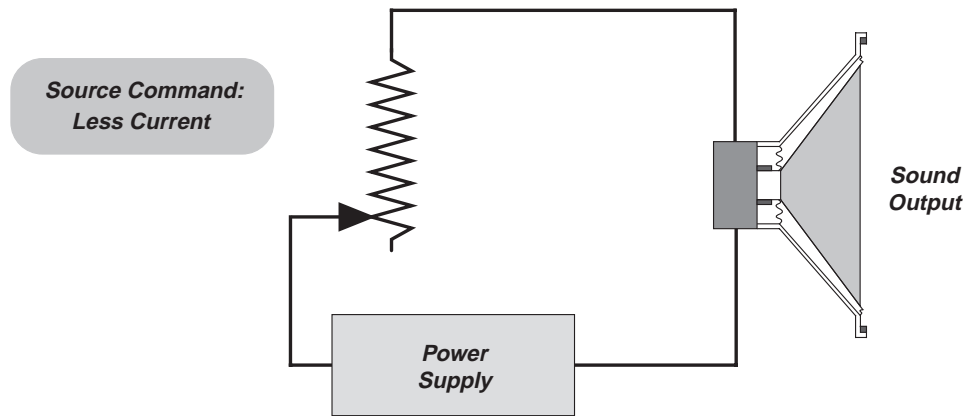

Figure 6.4: Amplifier command for less current.

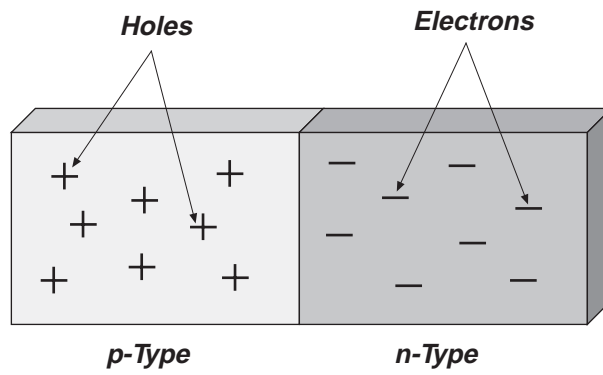

Figure 6.5: Semiconductor junction.

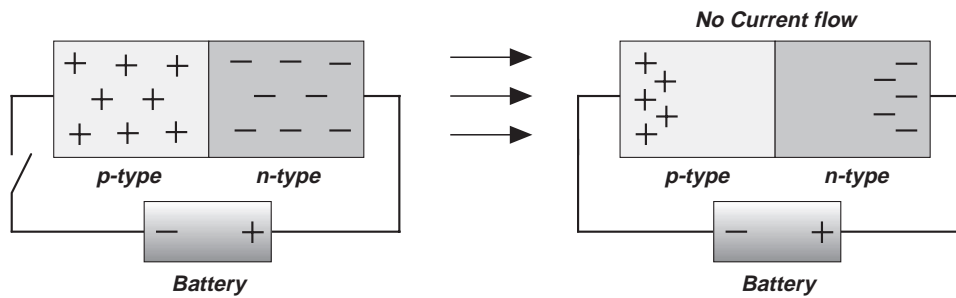

Figure 6.6: Reverse-biased semiconductor junction.

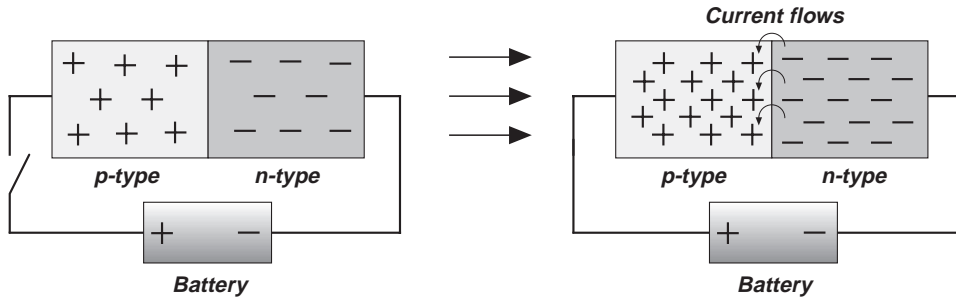

Figure 6.7: Forward-biased semiconductor junction.

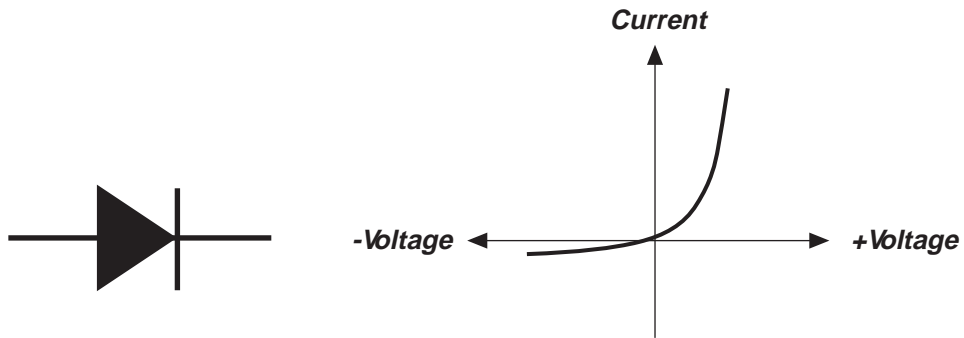

Figure 6.8: Symbol for diodes and its characteristics.

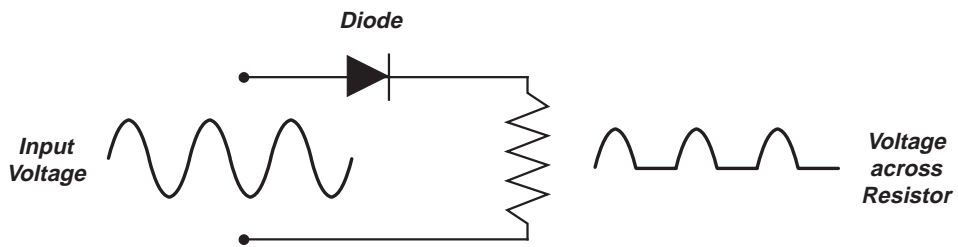

Figure 6.9: Rectifier action of a diode when an AC voltage is applied.

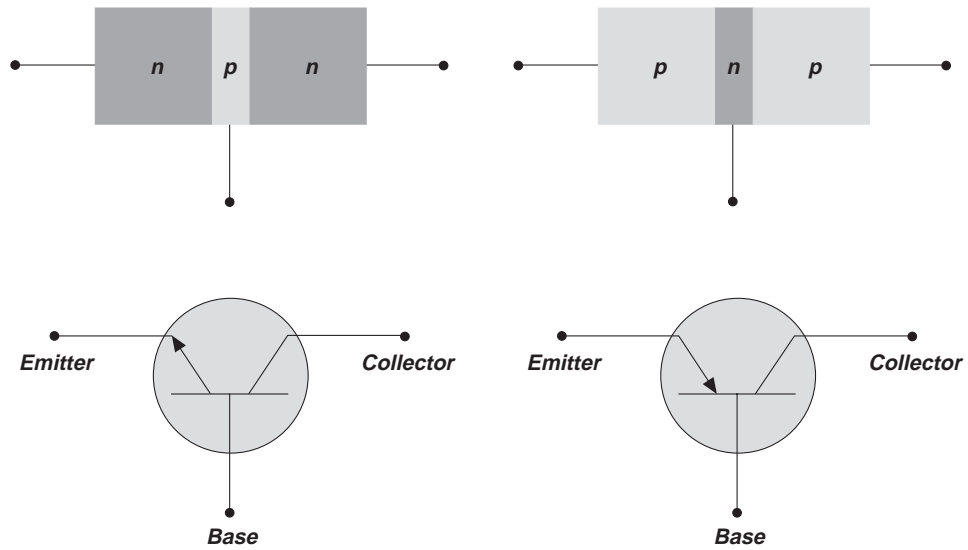

Figure 6.10: Diagram of transistor and its circuit symbol for two possibilities.

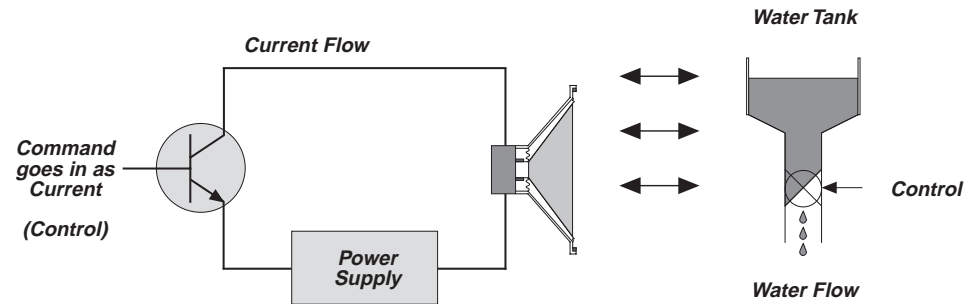

Figure 6.11: Amplifier action of transistor in a circuit compared to control of water flow.

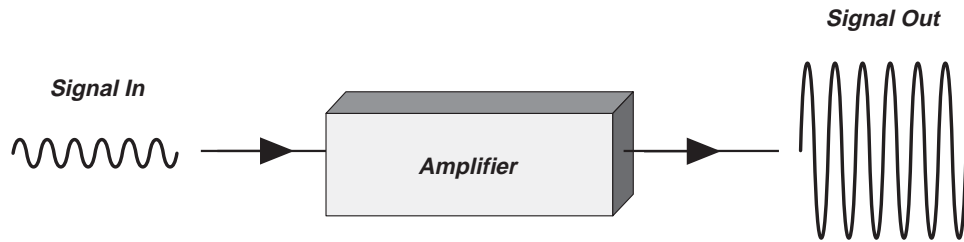

Figure 6.12: Function of an amplifier.

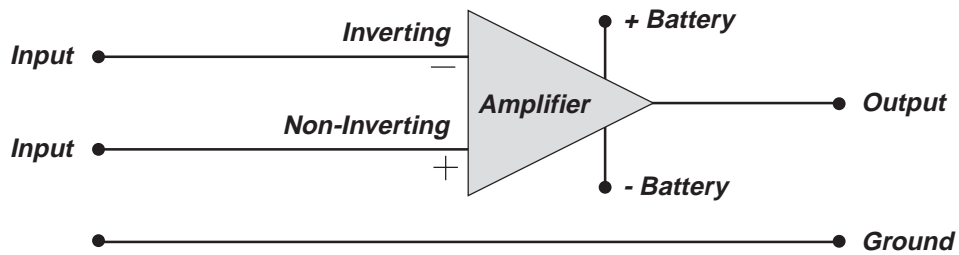

Figure 6.13: Amplifier integrated on a chip.

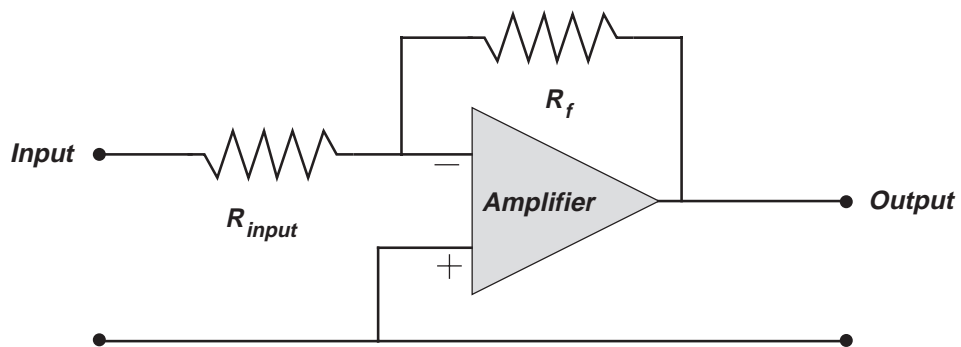

Figure 6.14: Operational amplifier with negative feedback.

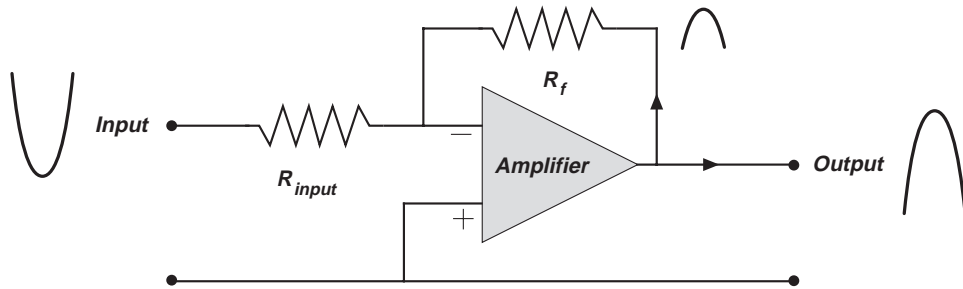

Figure 6.15: Negative feedback corrects fluctuations in gain.

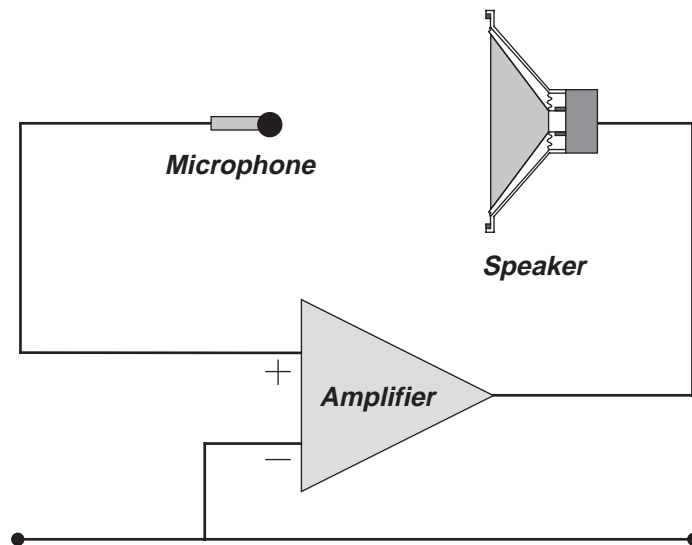

Figure 6.16: Positive feedback in large hall with a mike and a loudspeaker system driven by mike.

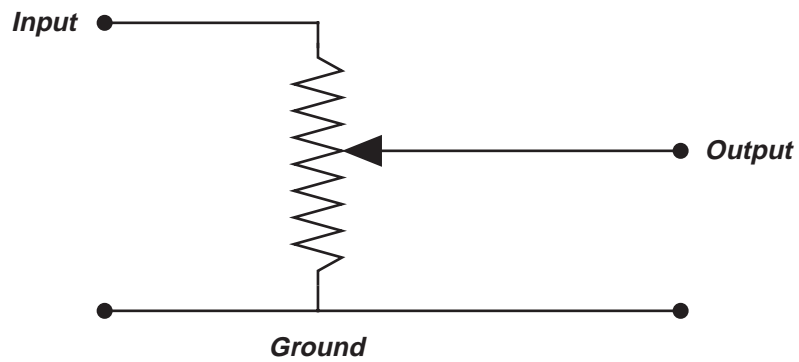

Figure 6.17: Volume control.

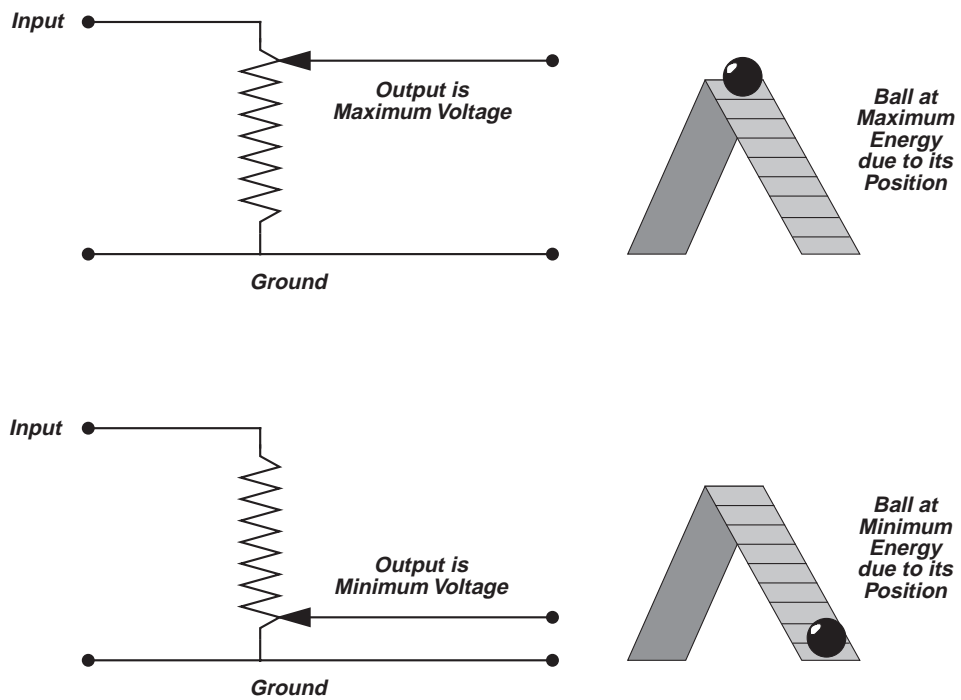

Figure 6.18: Comparison of potentiometer action with energy of a ball on a ladder.



Figure 6.19: Bass and Treble controls.

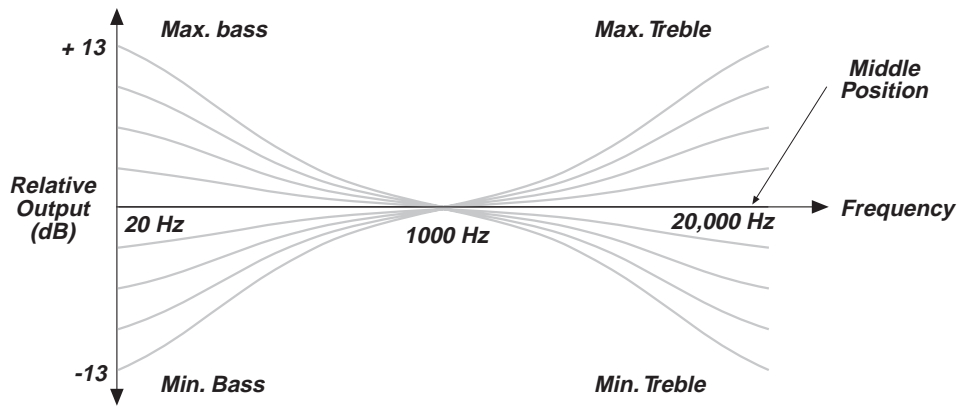

Figure 6.20: Effect on signal spectrum of Bass and Treble controls.

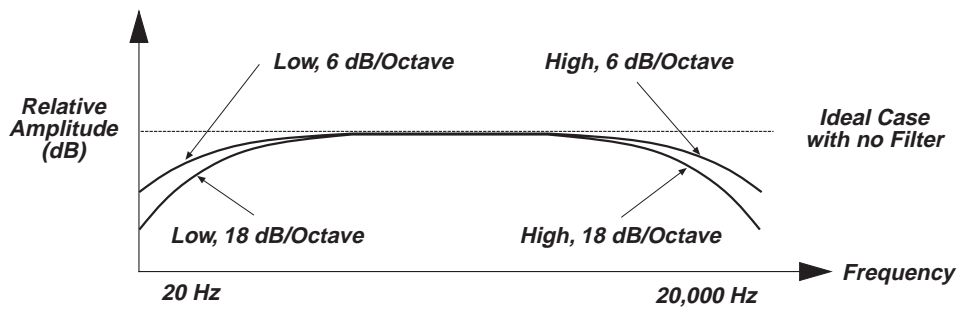

Figure 6.21: Action of LOW and HIGH filters with 6 dB/octave attenuation, and also with 18 db/octave attenuation.

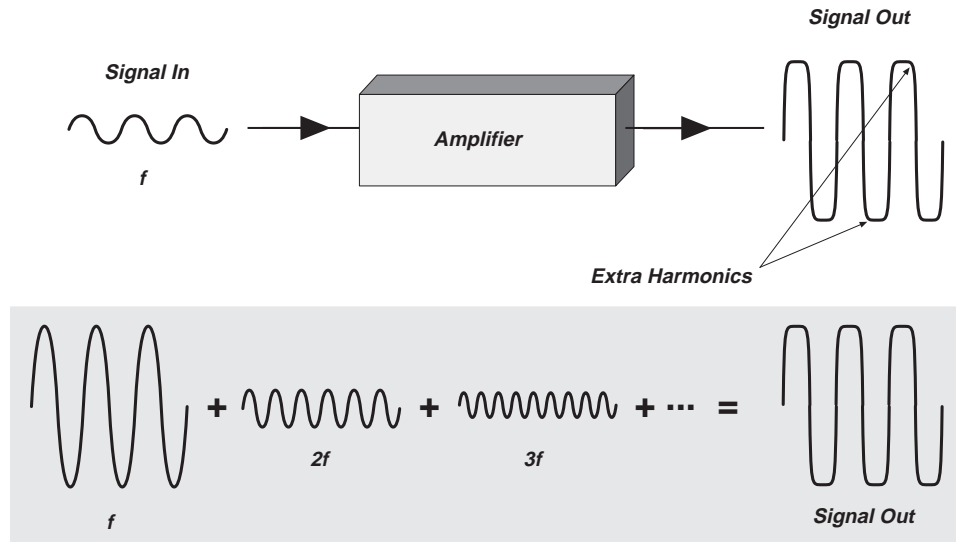

Figure 6.22: Harmonic distortion by amplifier.

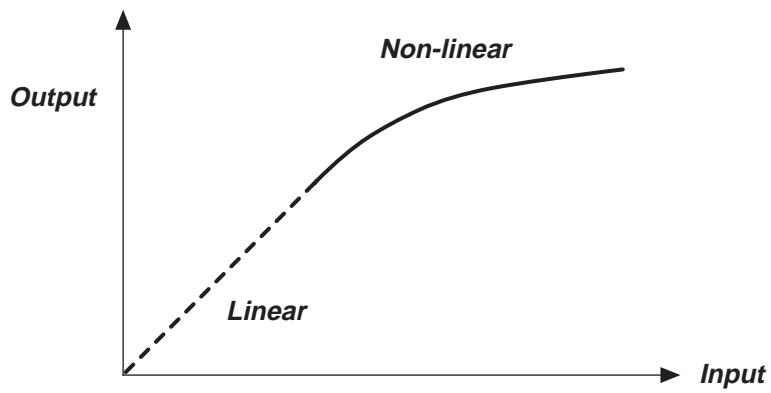

Figure 6.23: Non-linear gain of amplifier.

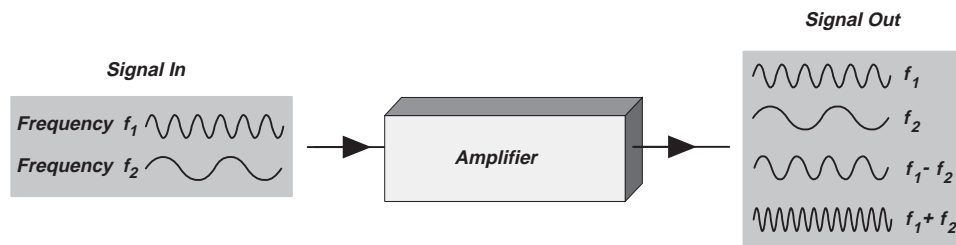

Figure 6.24: IM distortion in amplifier.

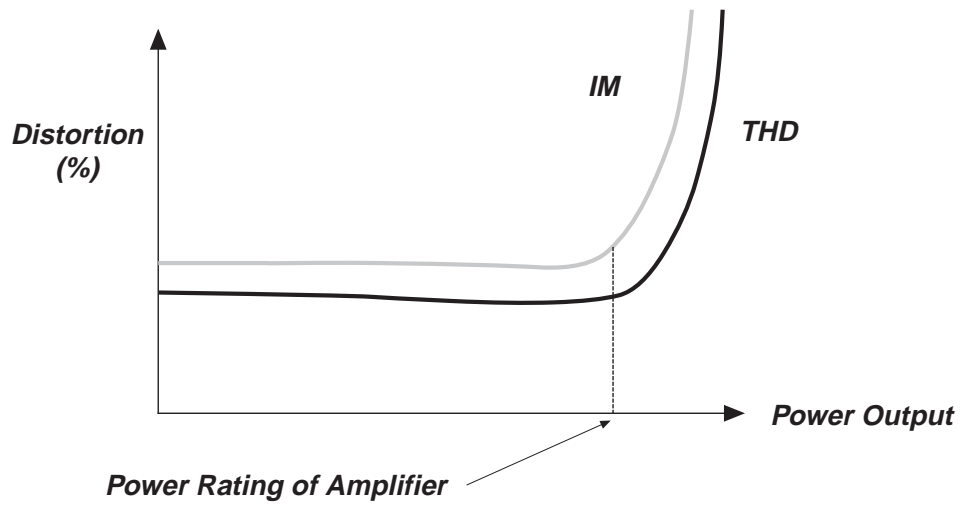

Figure 6.25: Distortion increases sharply about power rating of amplifier.

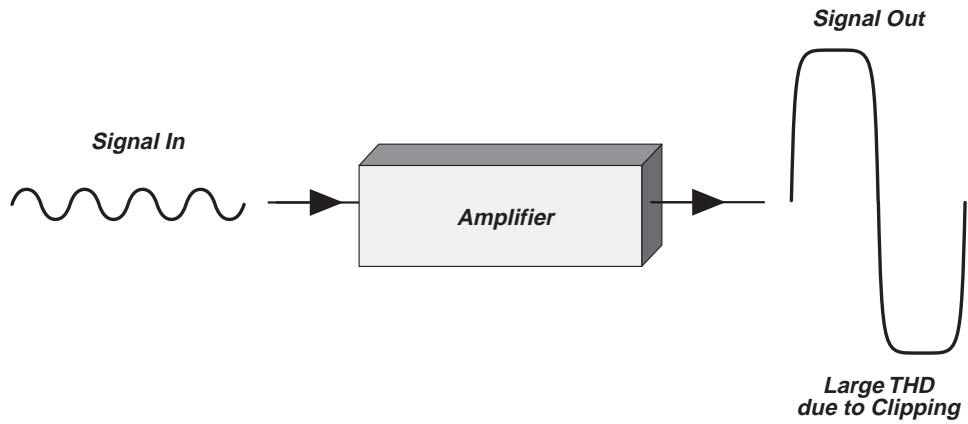

Figure 6.26: Clipping of waveform by amplifier at high output levels beyond the rated value.

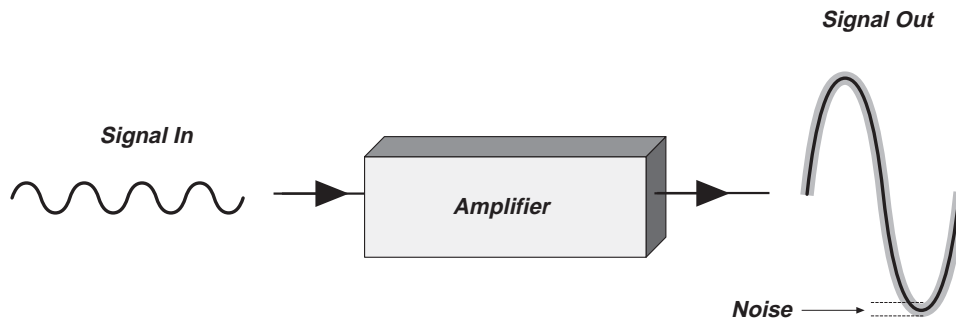

Figure 6.27: Effect of noise from amplifier.

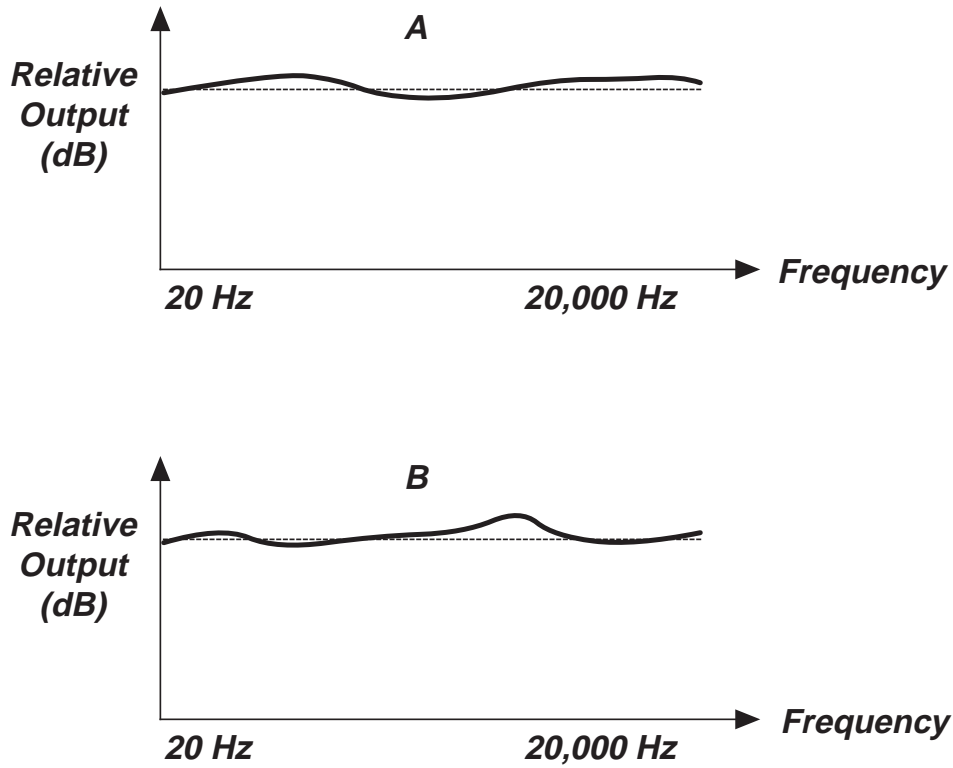

Figure 6.28: Comparing 2 amplifiers with the same specs. Even though their specs are the same, the amplifiers will sound different.

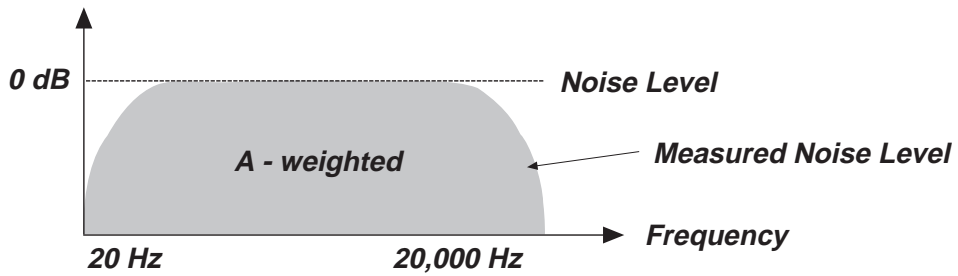

Figure 6.29: A-weighted method of measuring noise.

Chapter 7

Electromagnetism

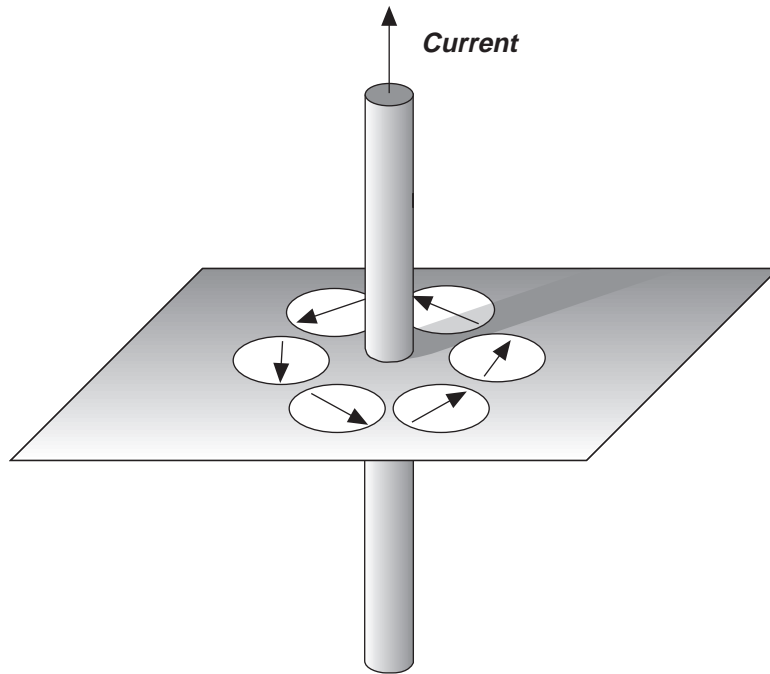

Figure 7.1: Effect of current in a wire on compasses around it.

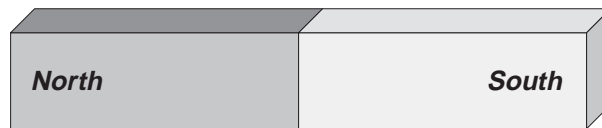

Figure 7.2: Bar magnet has a north pole and a south pole.

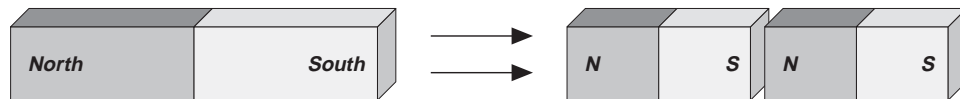

Figure 7.3: Cutting a bar magnet produces shorter magnets each with its own respective north and south poles.

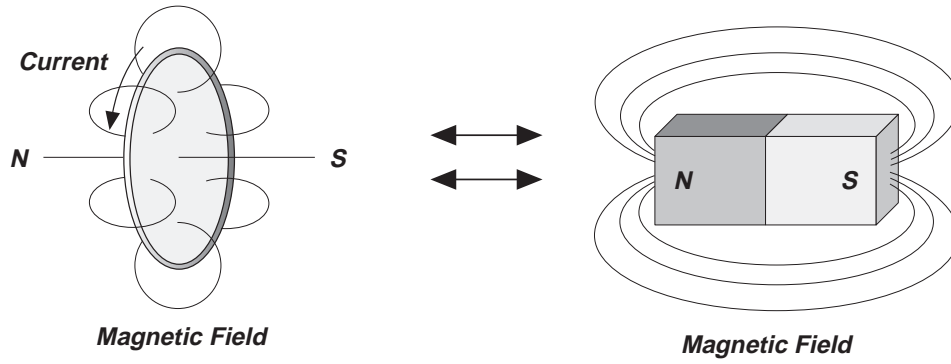

Figure 7.4: Magnetic dipole is the basic unit of magnetism.

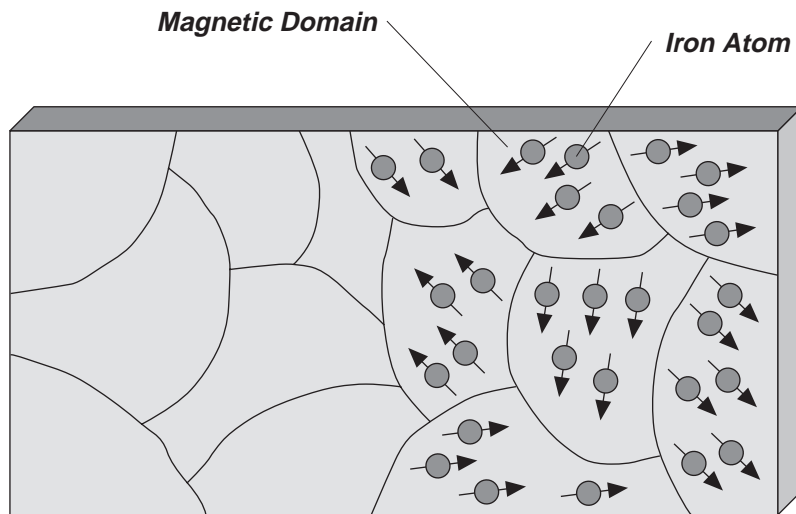

Figure 7.5: Unmagnetized piece of iron.

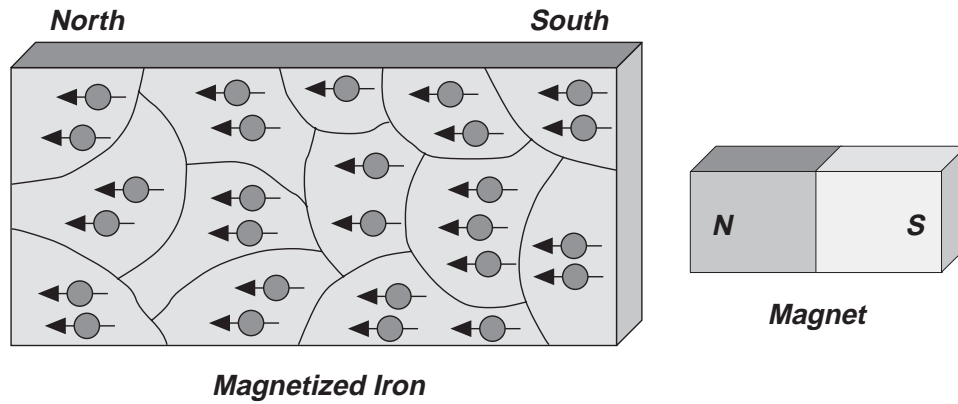

Figure 7.6: Alignment of domains in a piece of iron by a bar magnet. Iron becomes magnetized.

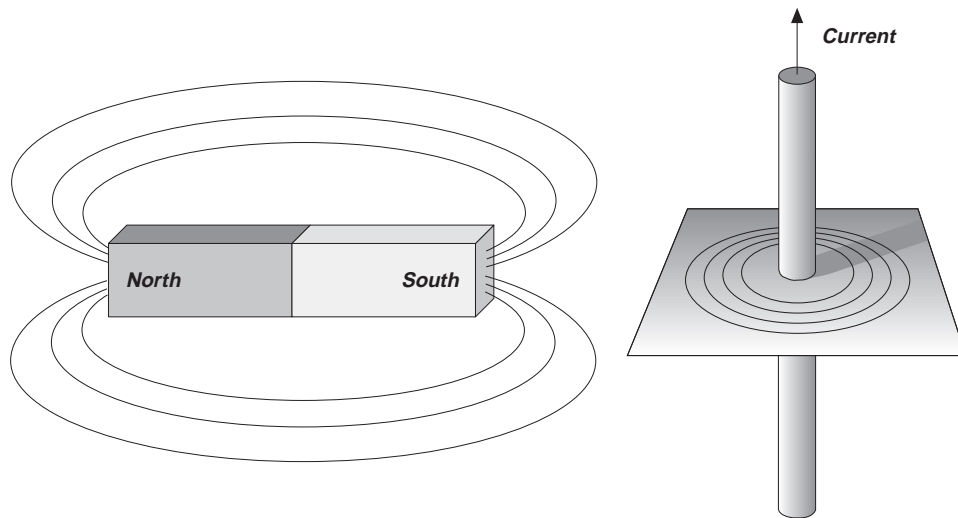

Figure 7.7: Magnetic field around a bar magnet and a wire carrying a current.

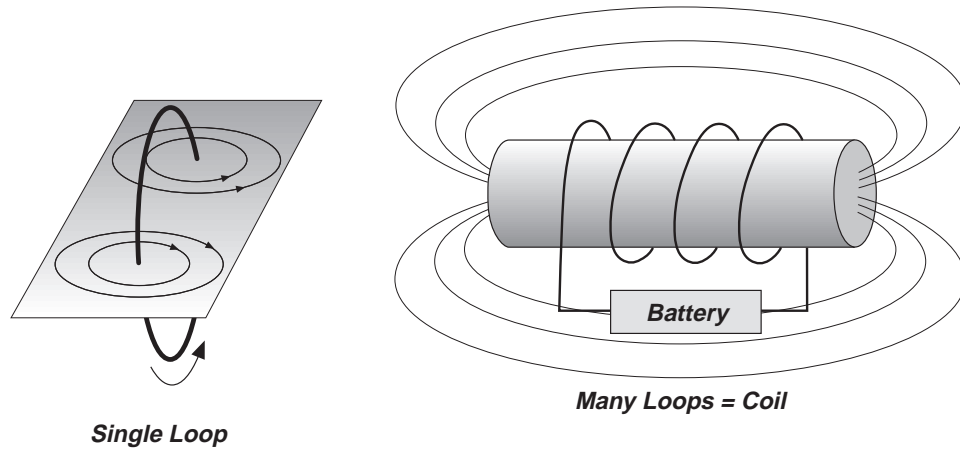

Figure 7.8: Increasing the magnetic field produced by a current in a wire: by forming a loop, and by using many loops.

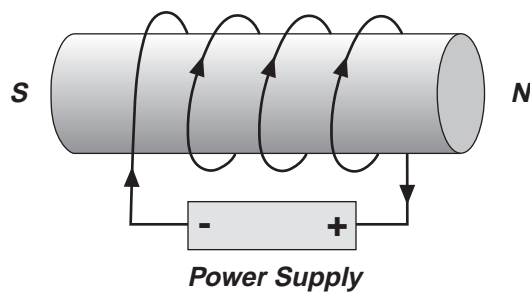

Figure 7.9: An electromagnet.

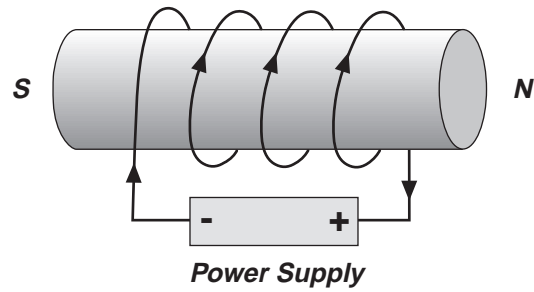

Figure 7.10: Determination of direction of magnetic field using first left-hand rule.

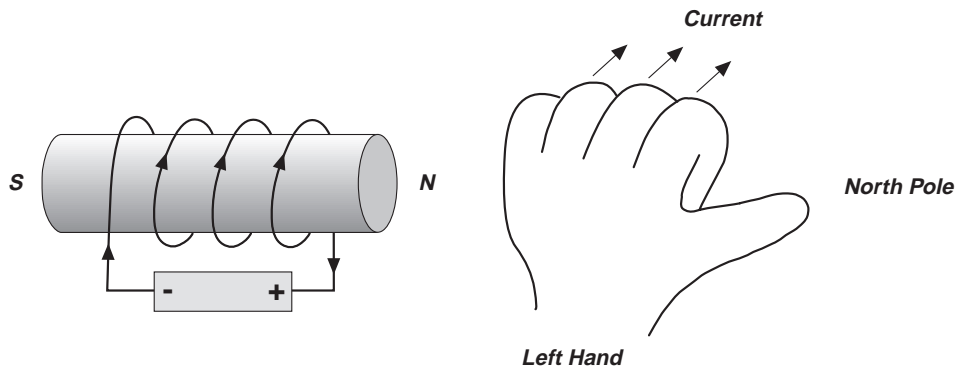

Figure 7.11: Rule for determining direction of magnetic field in an electromagnet.

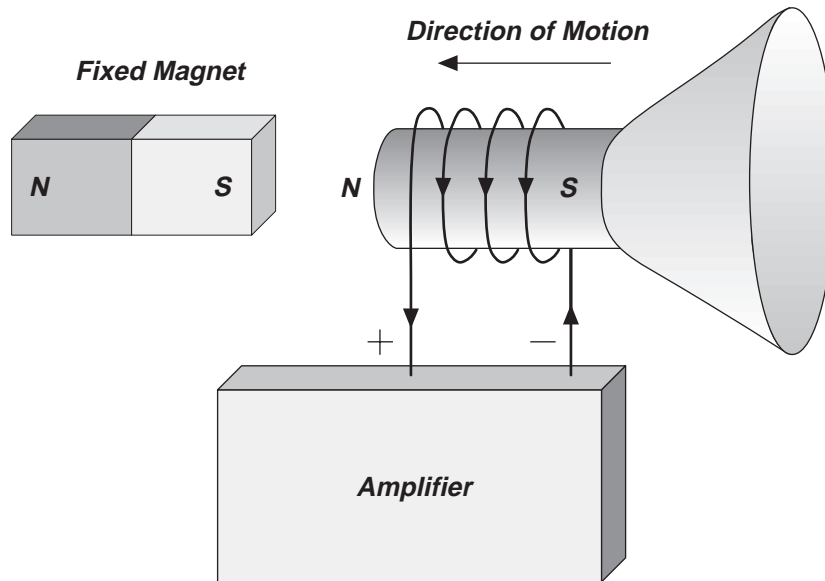

Figure 7.12: First left-hand rule and how a cone speaker works.

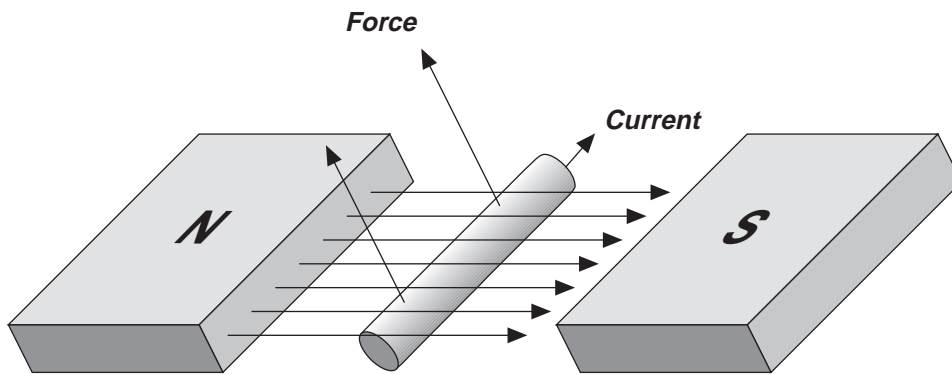

Figure 7.13: Force on wire carrying a current in a magnetic field.

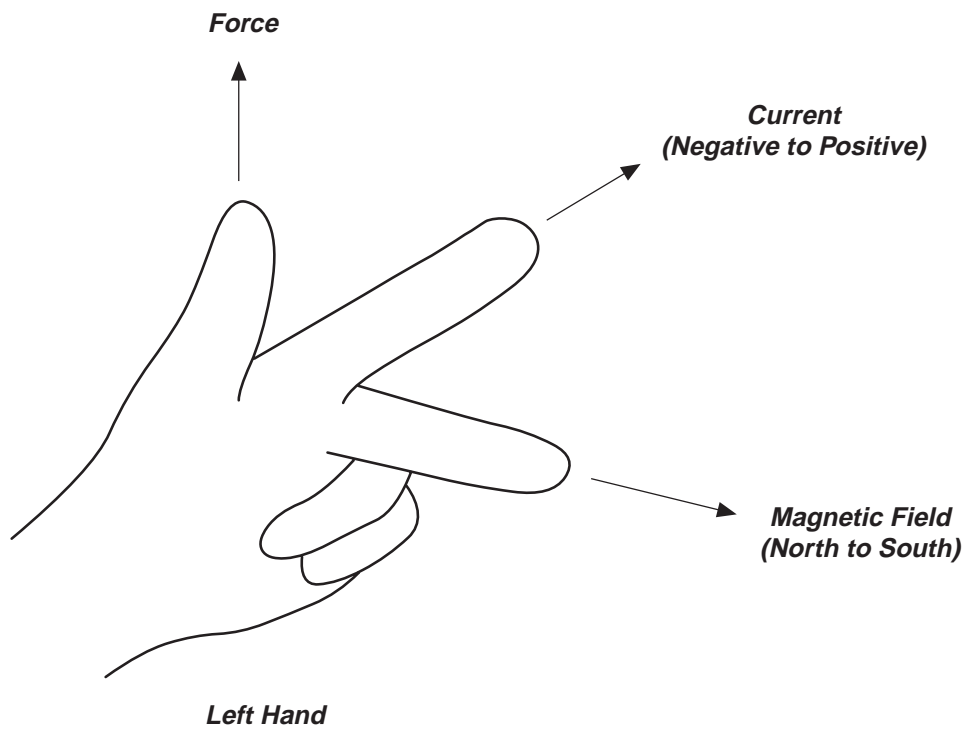

Figure 7.14: The second left-hand rule showing direction of force on wire carrying a current in a magnetic field.

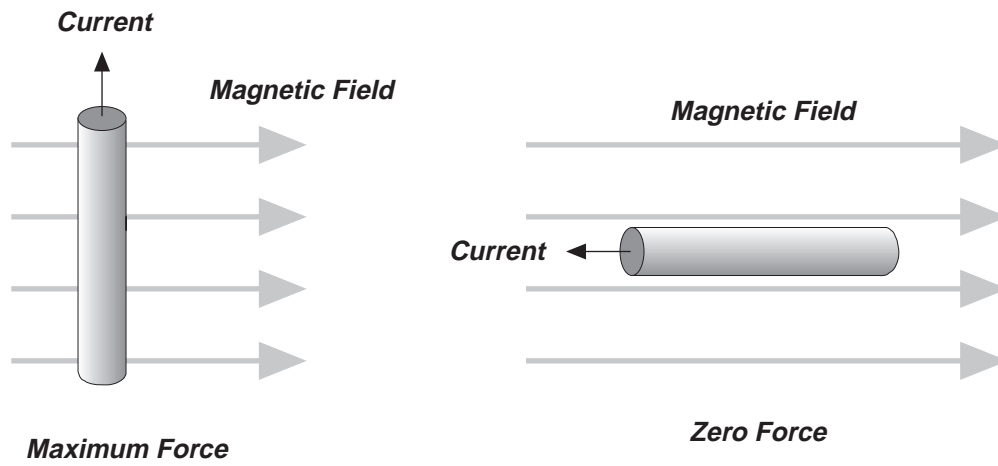

Figure 7.15: Direction of force depends on orientation of current with respect to magnetic field.

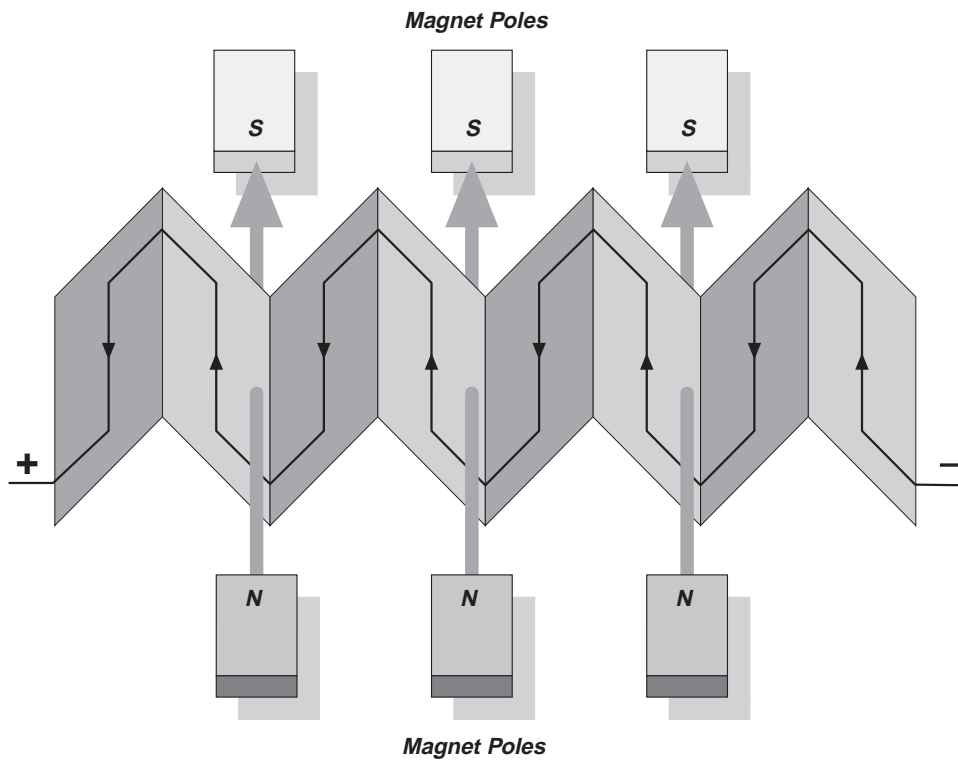

Figure 7.16: A Heil Speaker.

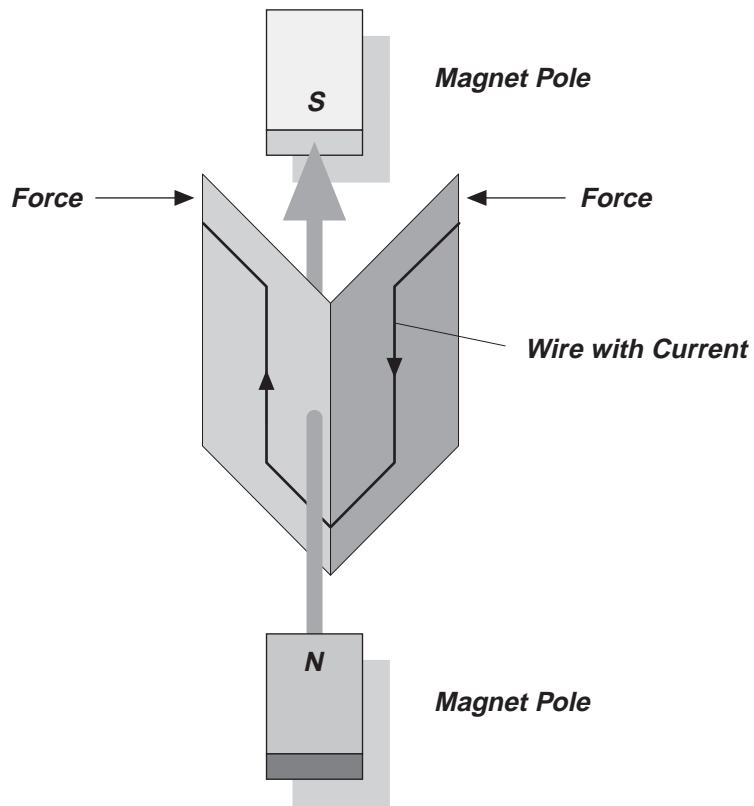

Figure 7.17: One set of folds in Heil speaker.

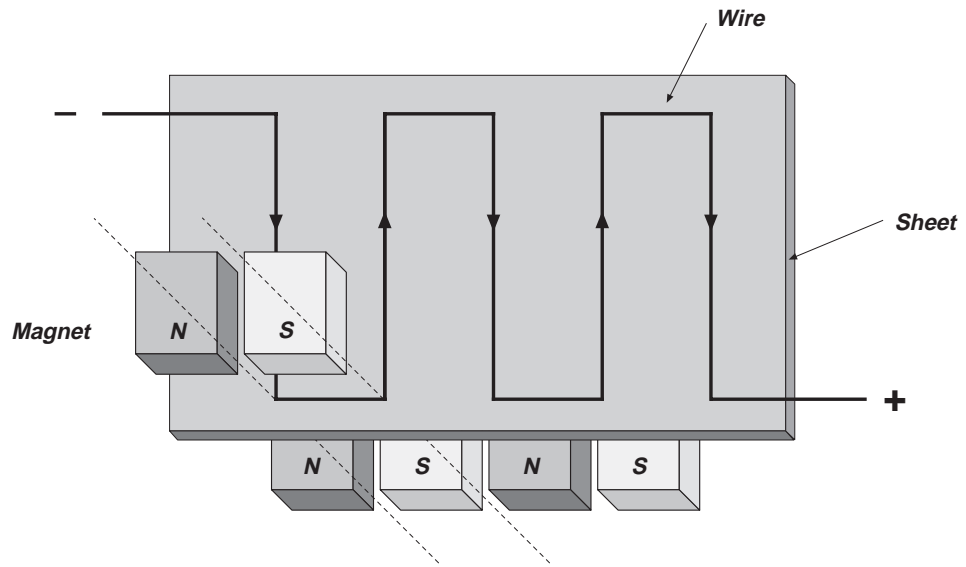

Figure 7.18: Magnetic Planar Speaker.

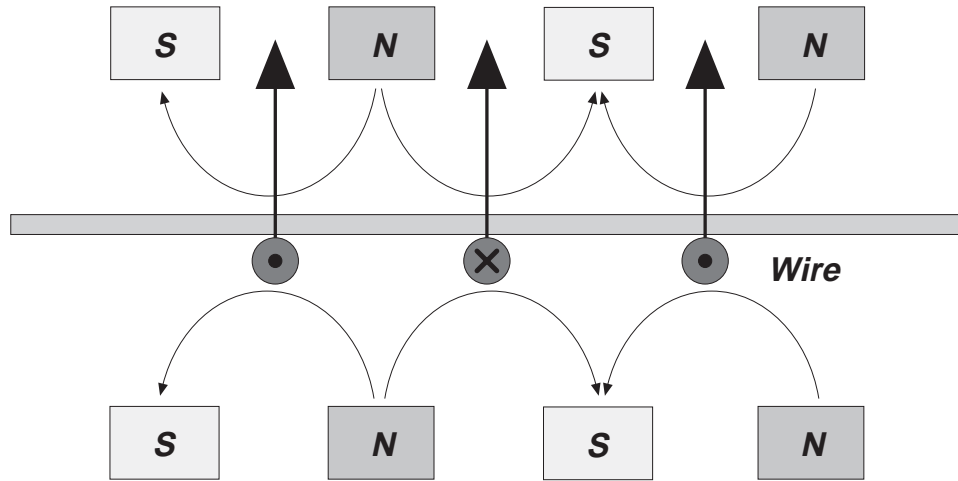

Figure 7.19: Forces on diaphragm when current direction is as indicated.

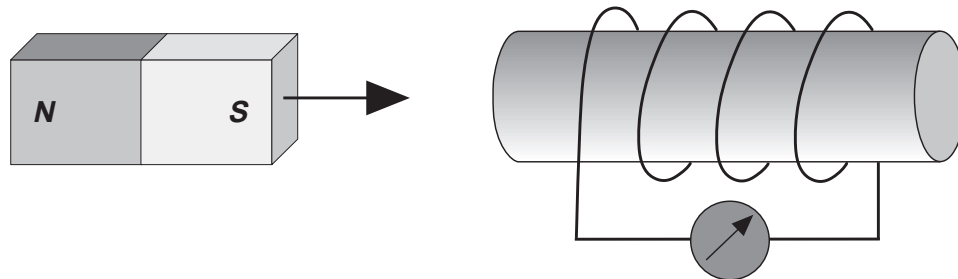

Figure 7.20: A bar magnet moving into a coil induces an electric current in that coil.

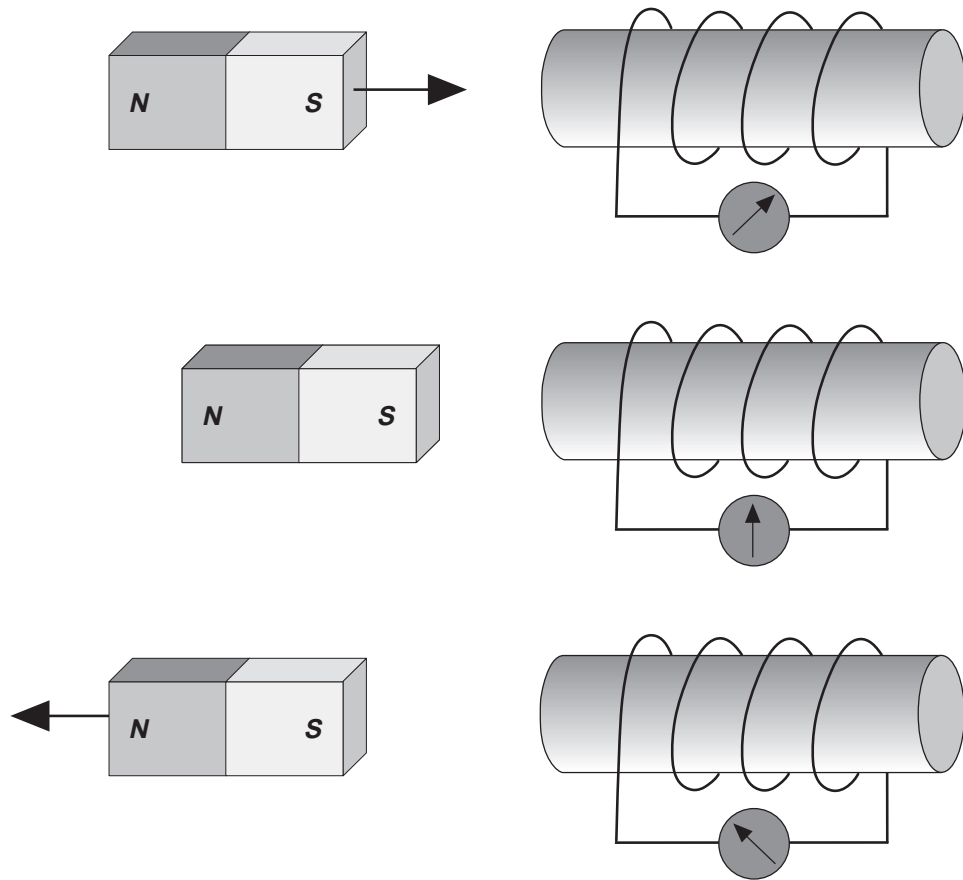

Figure 7.21: Induced current in coil by moving magnet.

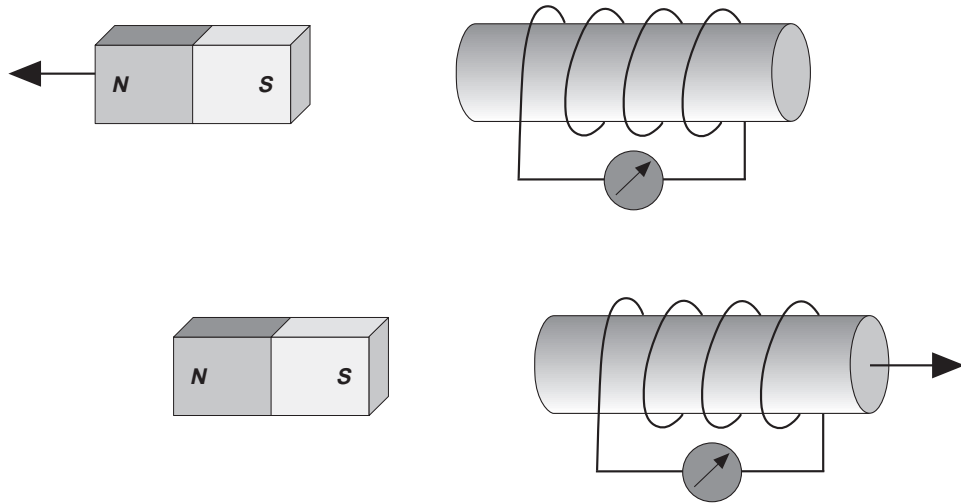

Figure 7.22: Significance of relative motion between magnet and coil.

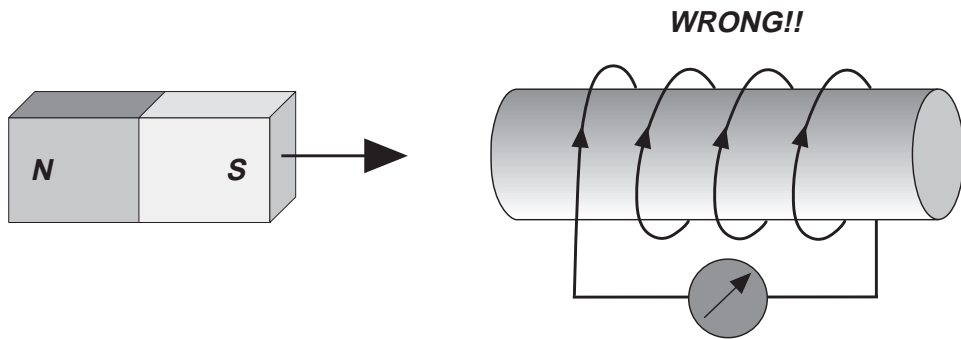

Figure 7.23: Direction of induced current (wrong).

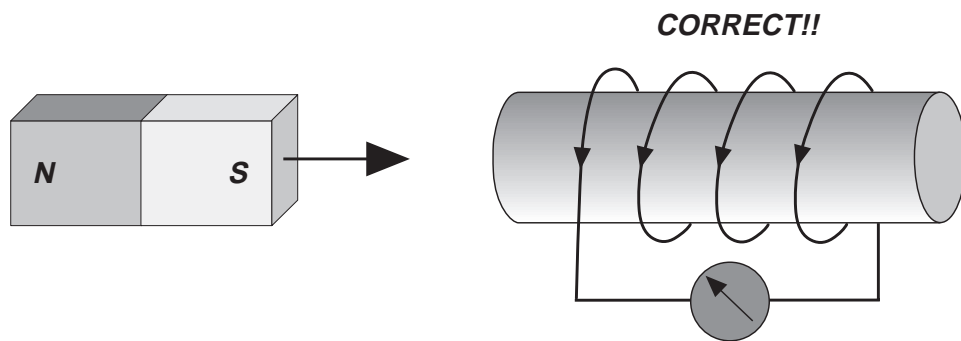

Figure 7.24: Direction of induced current (correct).

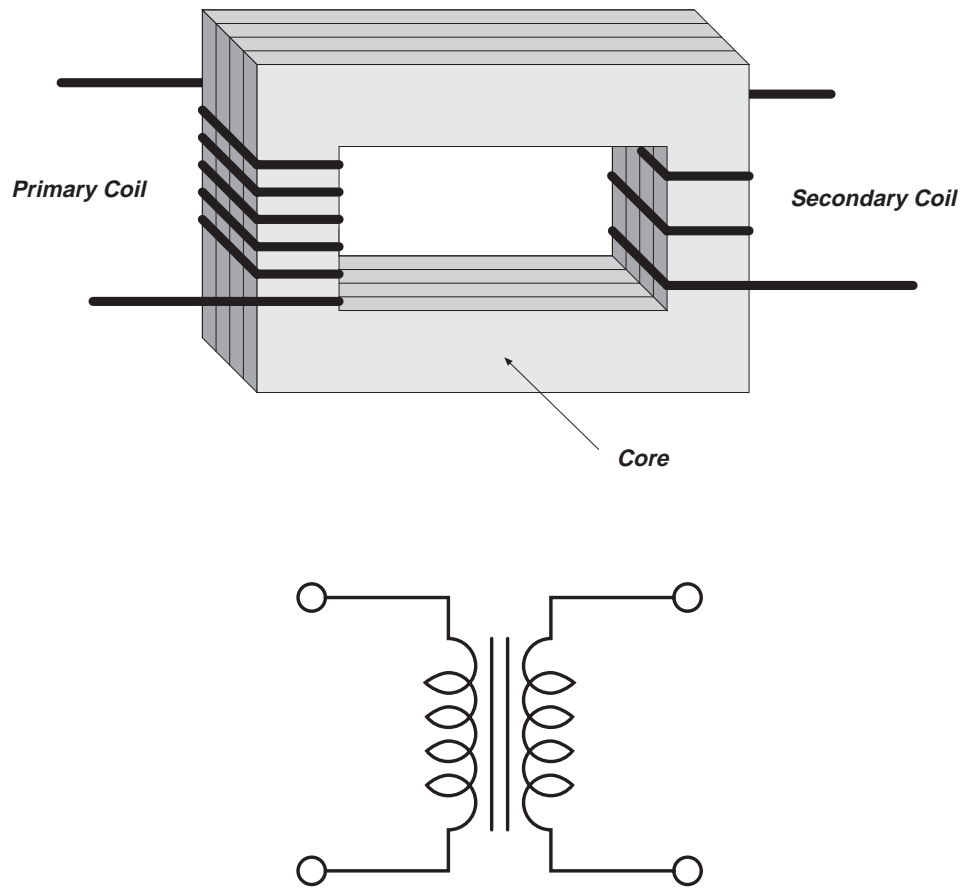

Figure 7.25: Schematic of a transformer and its circuit symbol.

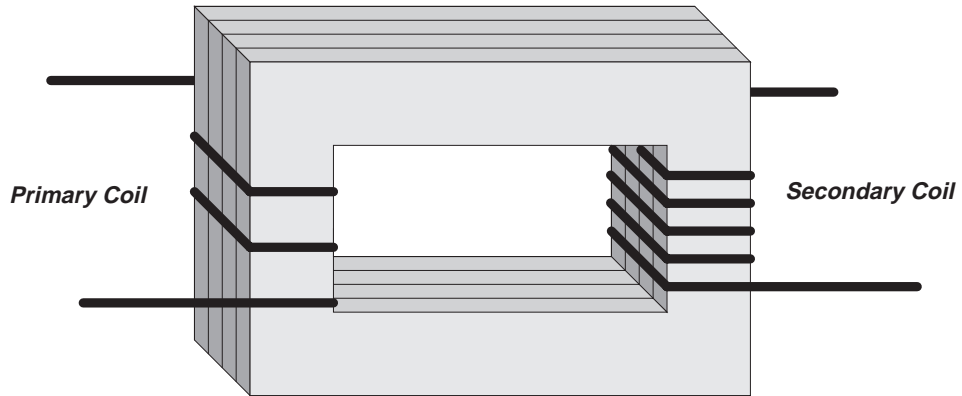

Figure 7.26: Step-up transformer.

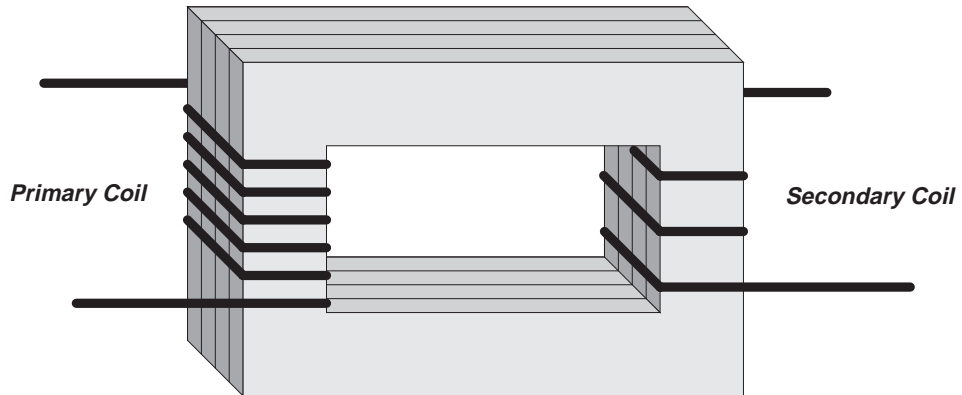

Figure 7.27: Step-down transformer.

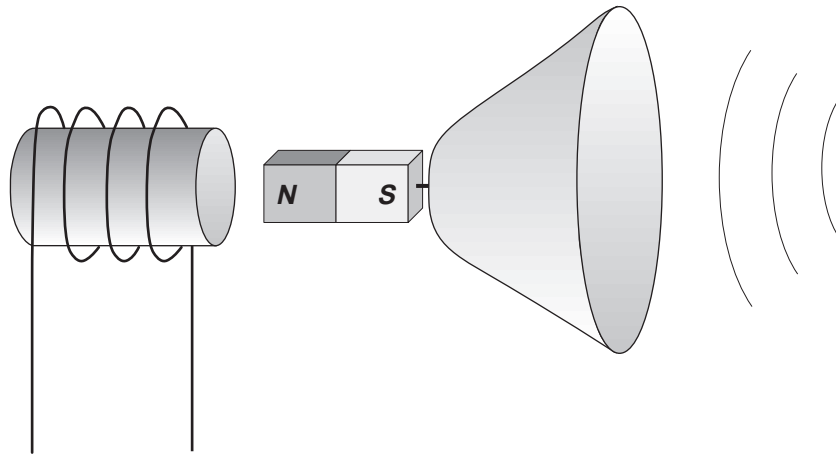

Figure 7.28: Schematic of microphone based on Faraday's law of induction.

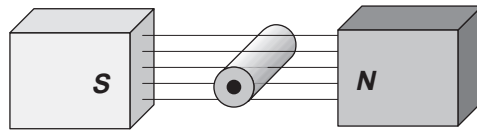

Figure 7.29: Exercise 7.14.

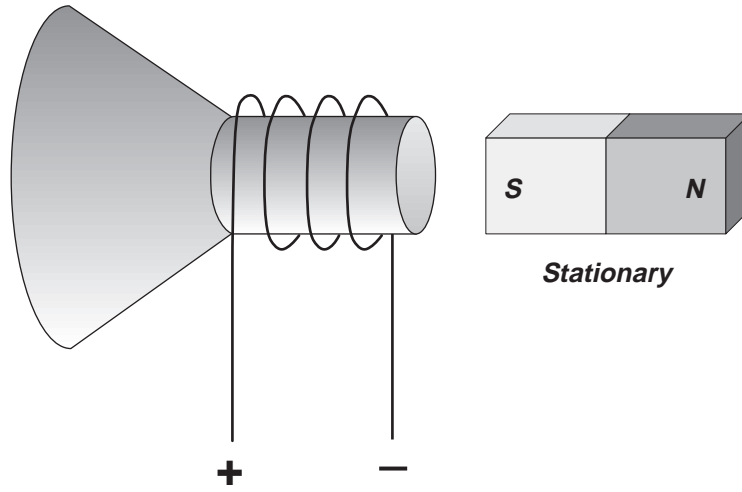

Figure 7.30: Exercise 7.15.

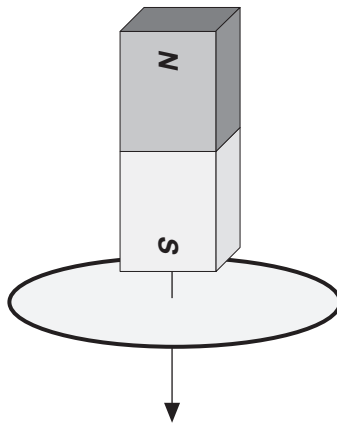

Figure 7.31: Exercise 7.18.

Chapter 8

Electromagnetic Waves and Tuners

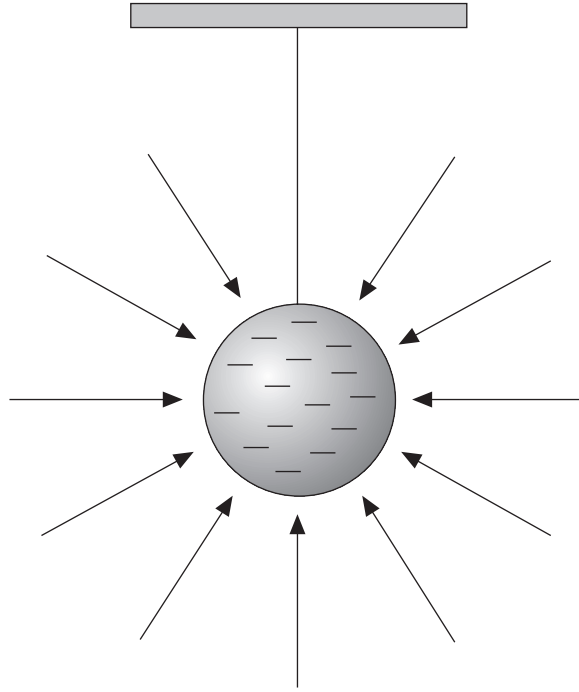

Figure 8.1: Electric Field around charged ping-pong ball.

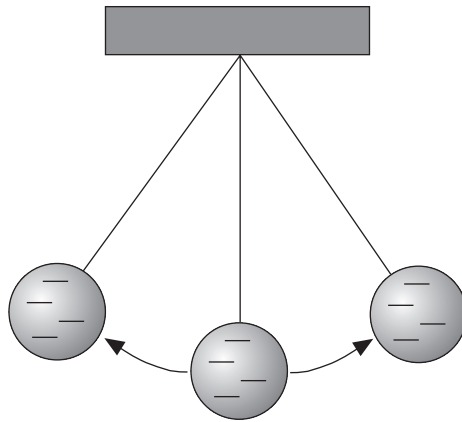

Figure 8.2: Oscillating charged ball.

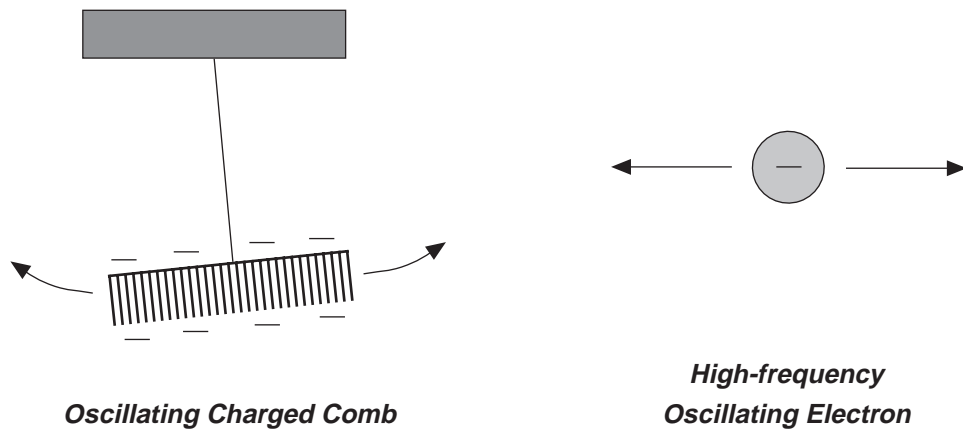

Figure 8.3: Generation of electromagnetic waves at two different frequencies.

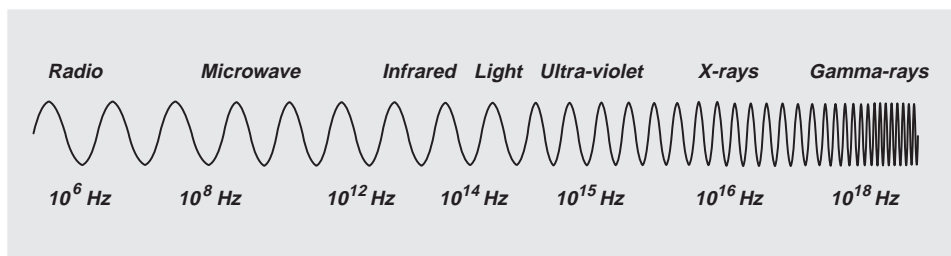

Figure 8.4: Spectrum of electromagnetic waves.

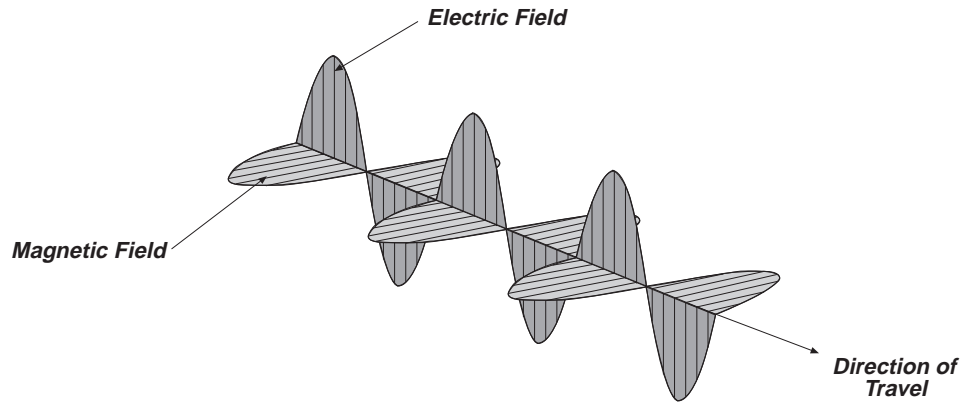

Figure 8.5: Electromagnetic waves are transverse waves with oscillating electric and magnetic fields.

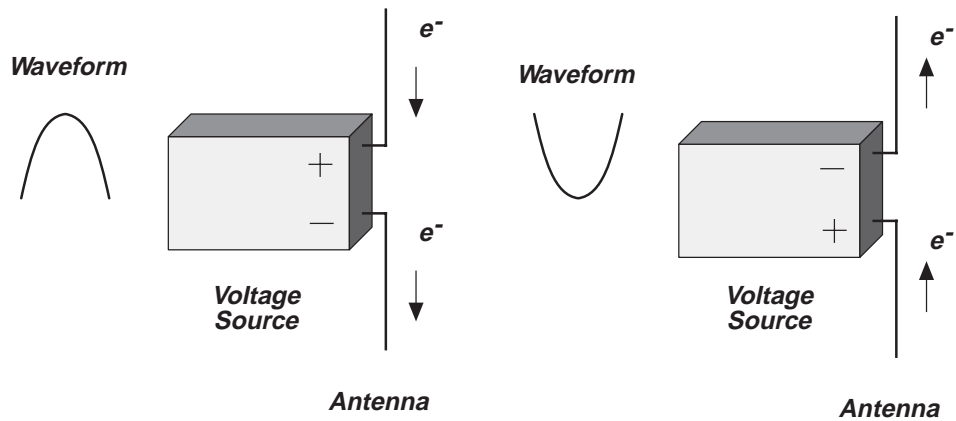

Figure 8.6: Production of electromagnetic waves by oscillating electrons in antenna.

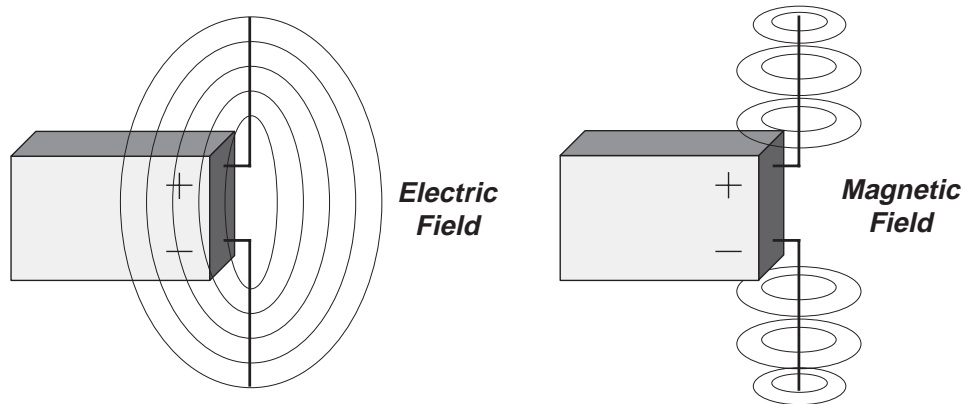

Figure 8.7: Generation of electric and magnetic fields by antenna.

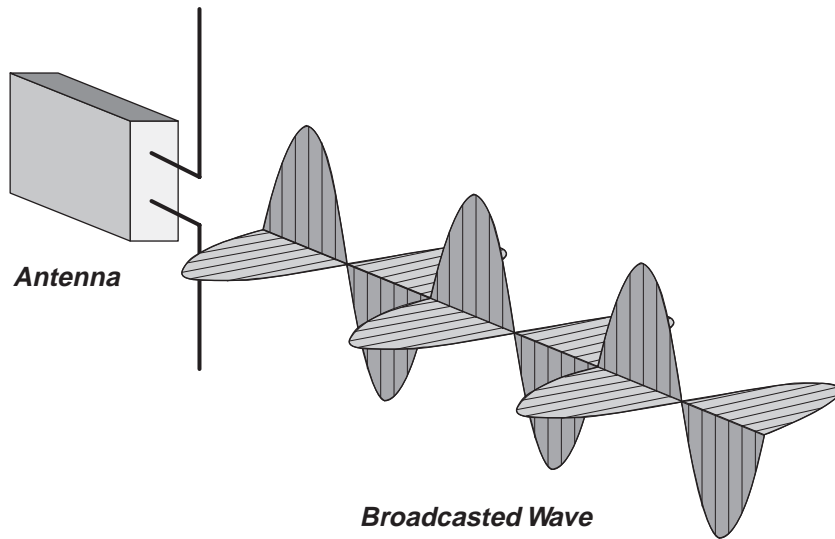

Figure 8.8: Production of electromagnetic waves by antenna.

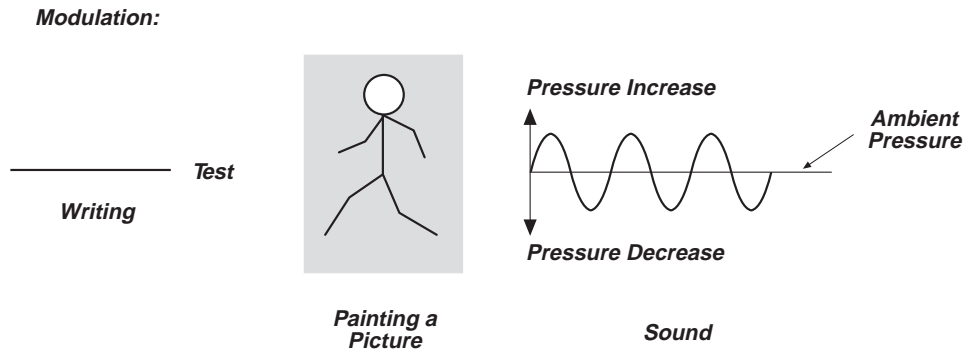

Figure 8.9: Some examples of modulation.

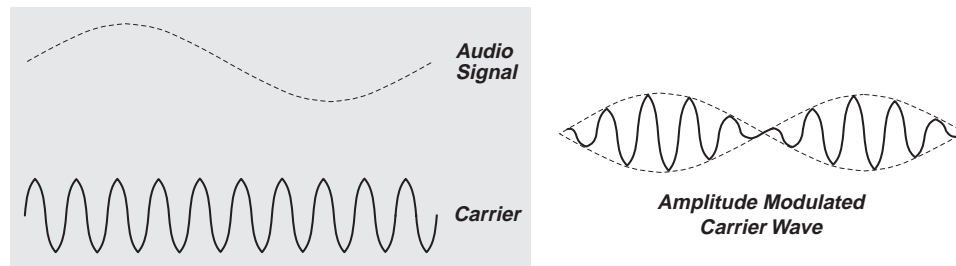

Figure 8.10: Amplitude modulation.

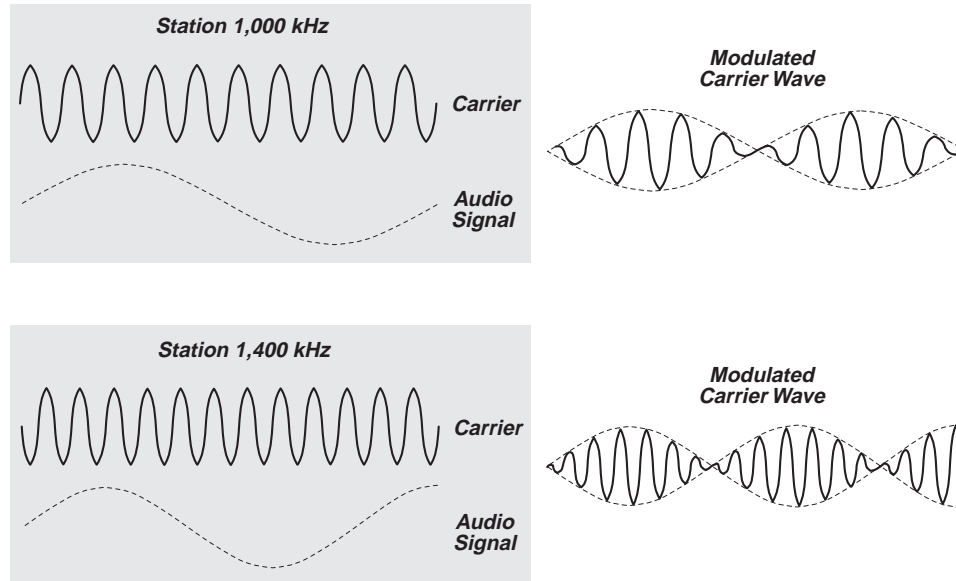

Figure 8.11: Carrier and audio signals broadcast by two stations.

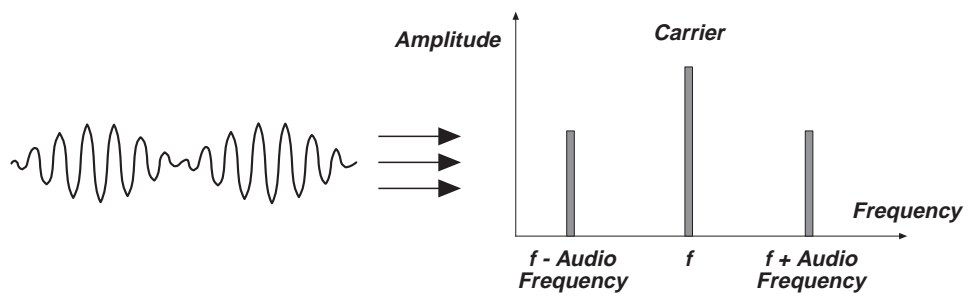

Figure 8.12: Spectrum of an AM carrier at frequency f when modulated by audio signal.

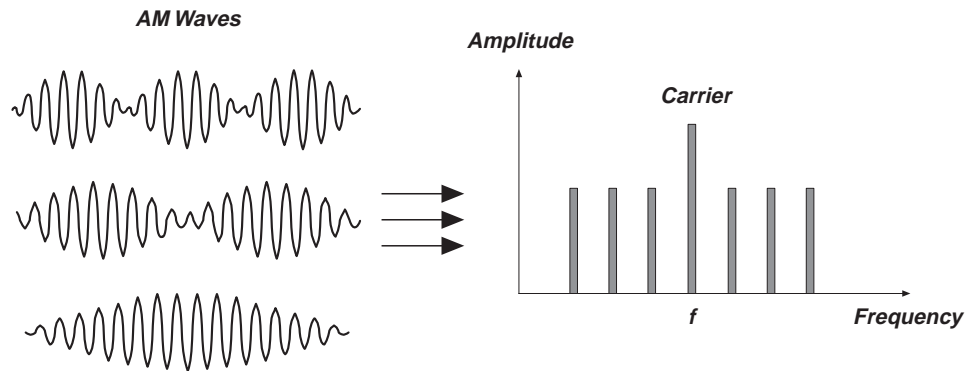

Figure 8.13: Audio frequencies modulating carrier.

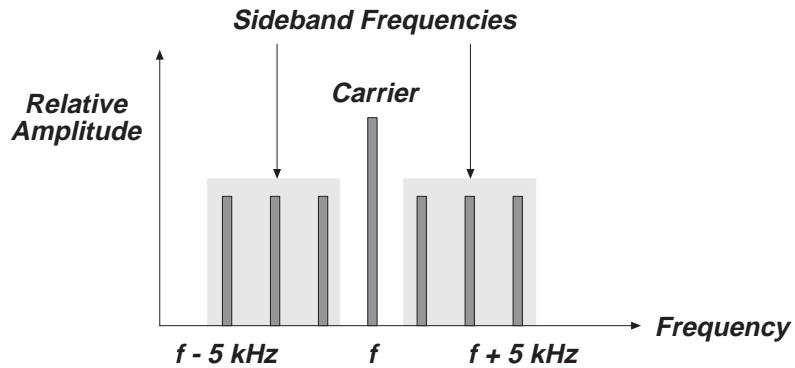

Figure 8.14: Spectrum of frequencies on carrier for audio frequencies up to 5 kHz.

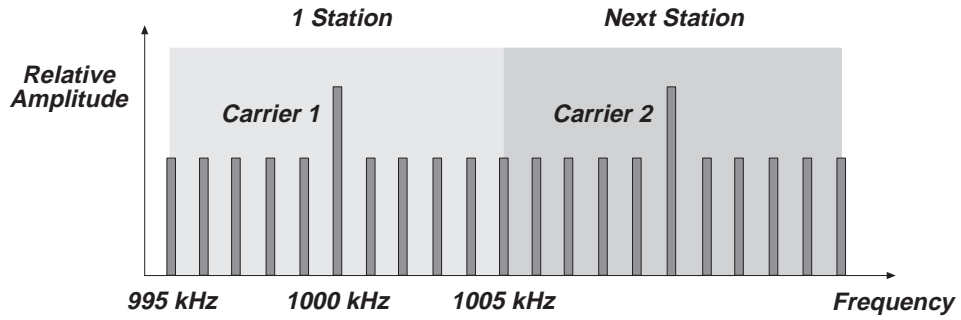

Figure 8.15: Spectrum of frequencies due to modulation of carrier.

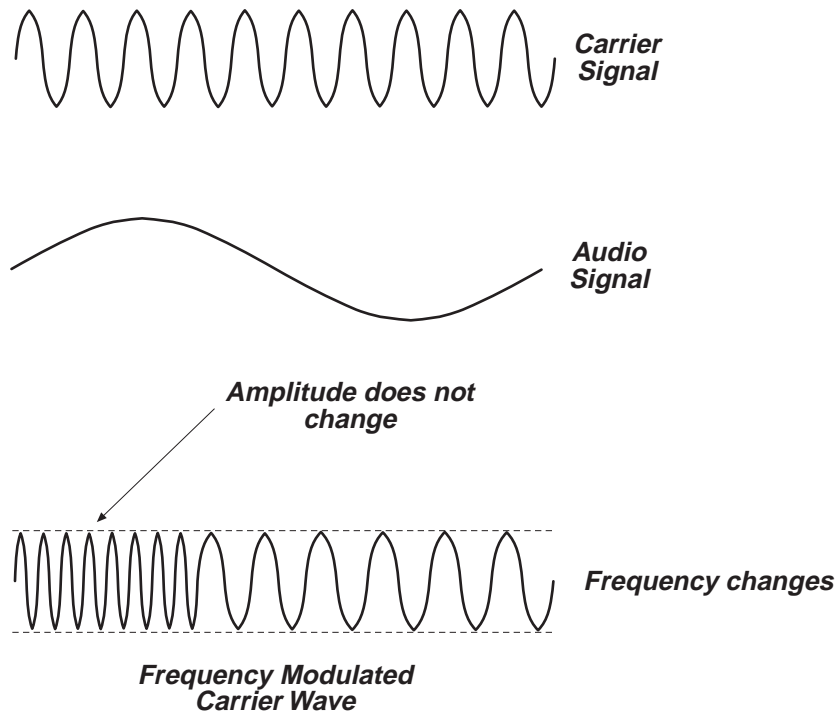

Figure 8.16: Frequency modulation (FM).

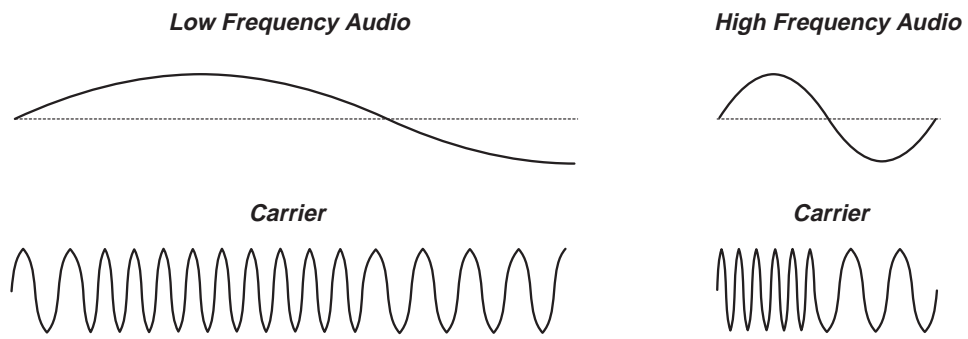

Figure 8.17: A low frequency and a high frequency audio signal frequency modulating a carrier.

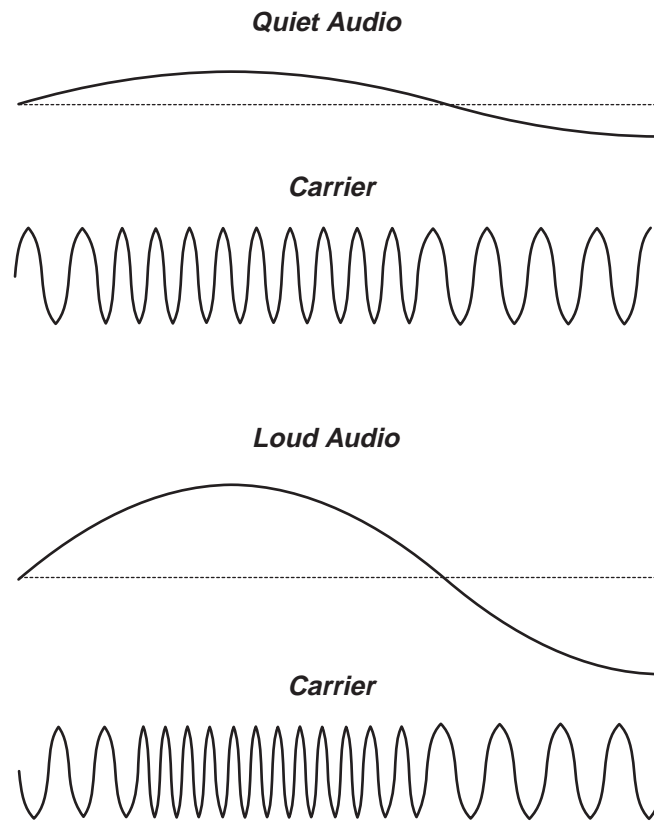

Figure 8.18: A loud and a quiet audio signal frequency modulating a carrier.

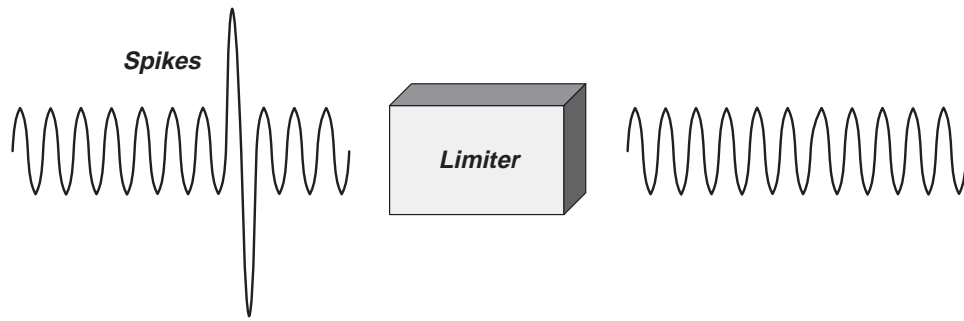

Figure 8.19: Action of limiter in FM.

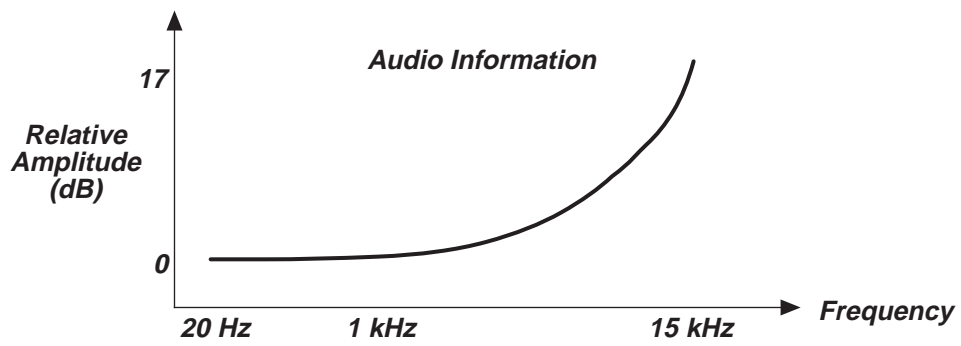

Figure 8.20: Pre-emphasis in FM broadcasting.

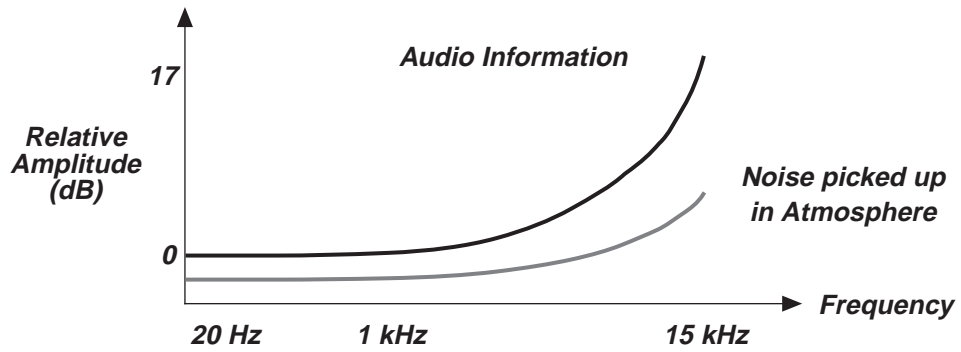

Figure 8.21: Information brought to tuner on carrier.

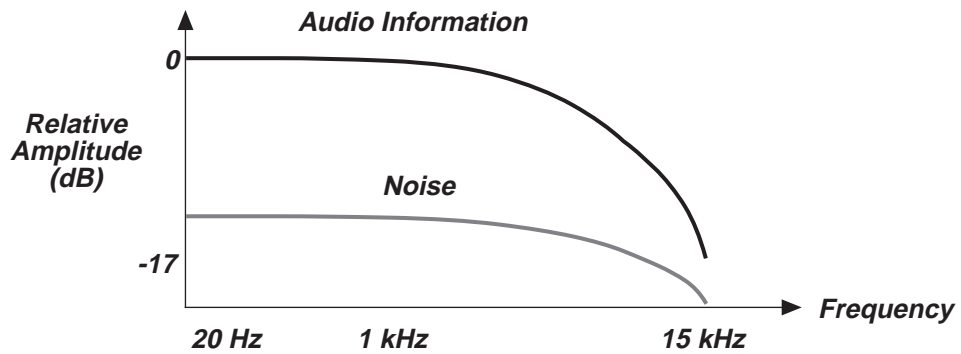

Figure 8.22: De-emphasis of audio information to reduce high frequency noise.

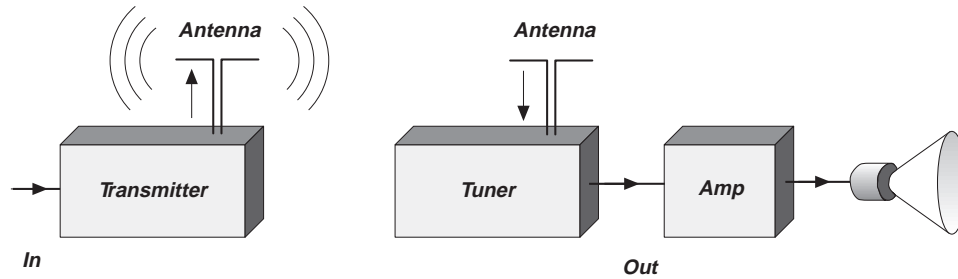

Figure 8.23: Elements of radio communications.

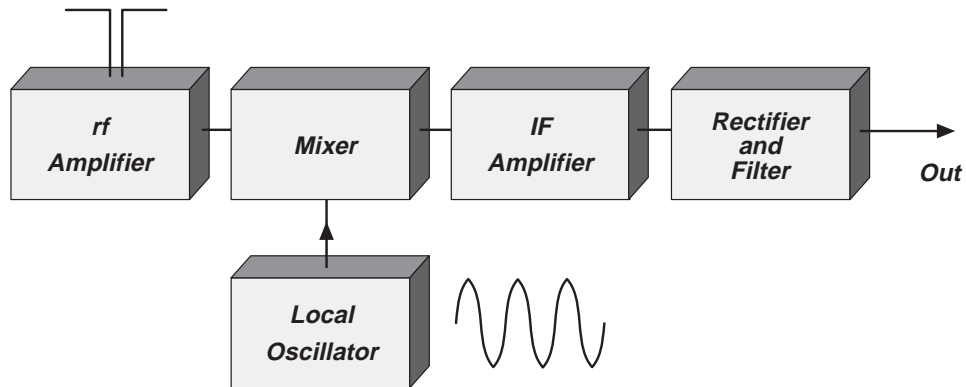

Figure 8.24: Superheterodyne receiver.

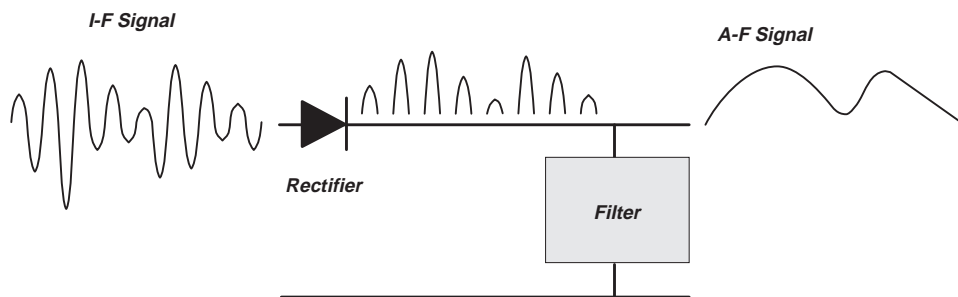

Figure 8.25: Processing part of AM signal with a simple diode and filters.

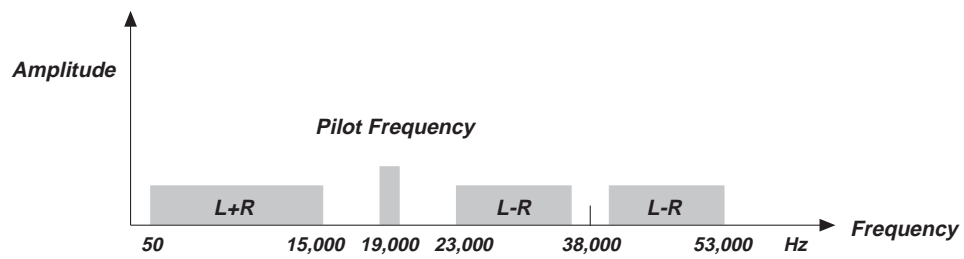

Figure 8.26: Audio information which will modulate carrier in stereo broadcasting.

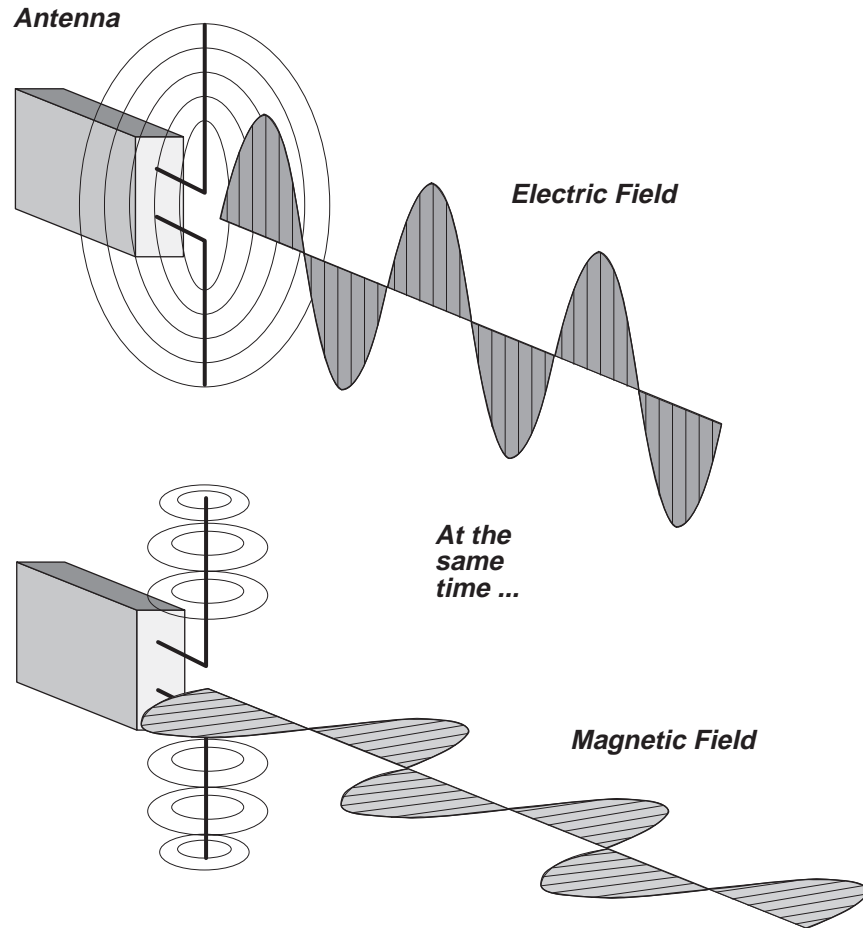

Figure 8.27: Alternating current in antenna produces electromagnetic wave.

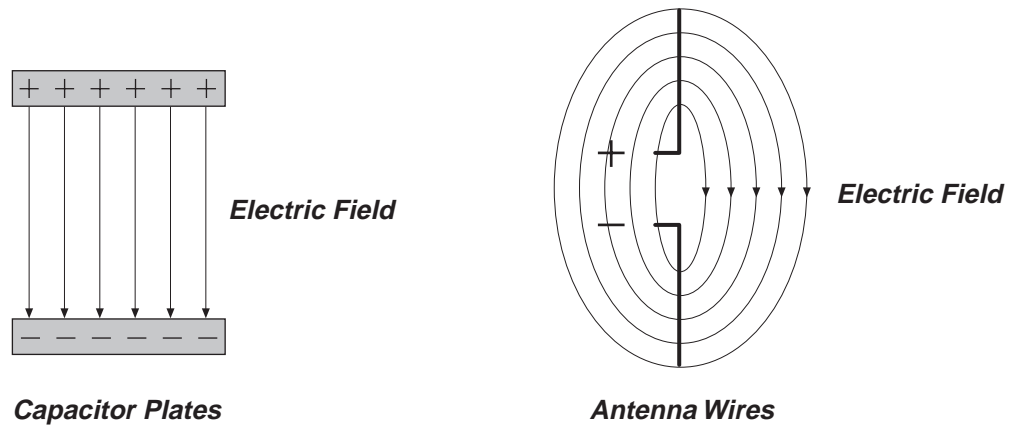

Figure 8.28: Electric field around charged antenna wires is similar to that between charged capacitor plates.

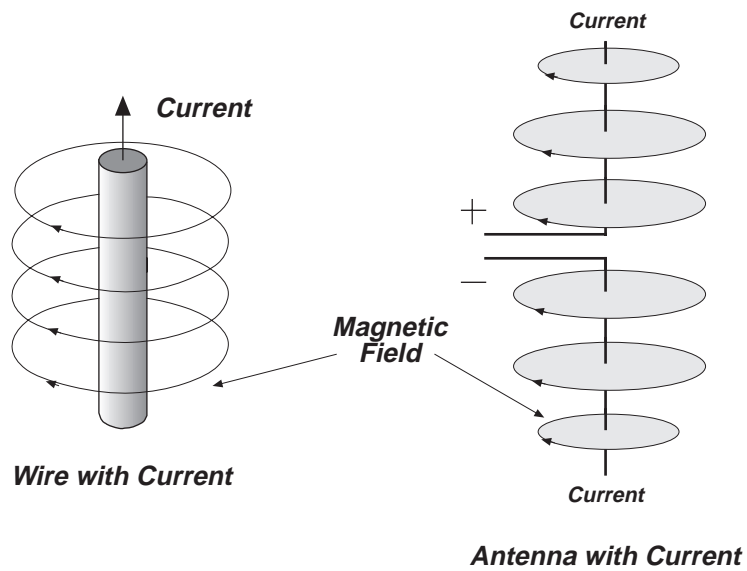

Figure 8.29: Magnetic fields around a wire and antenna with current.

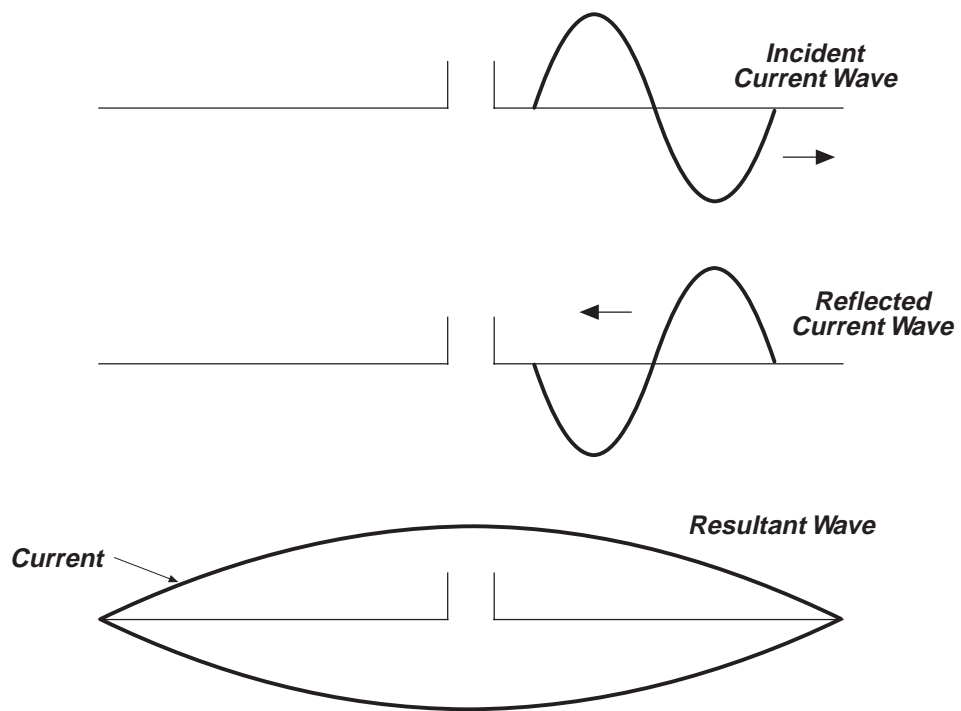

Figure 8.30: Development of a standing wave on antenna.

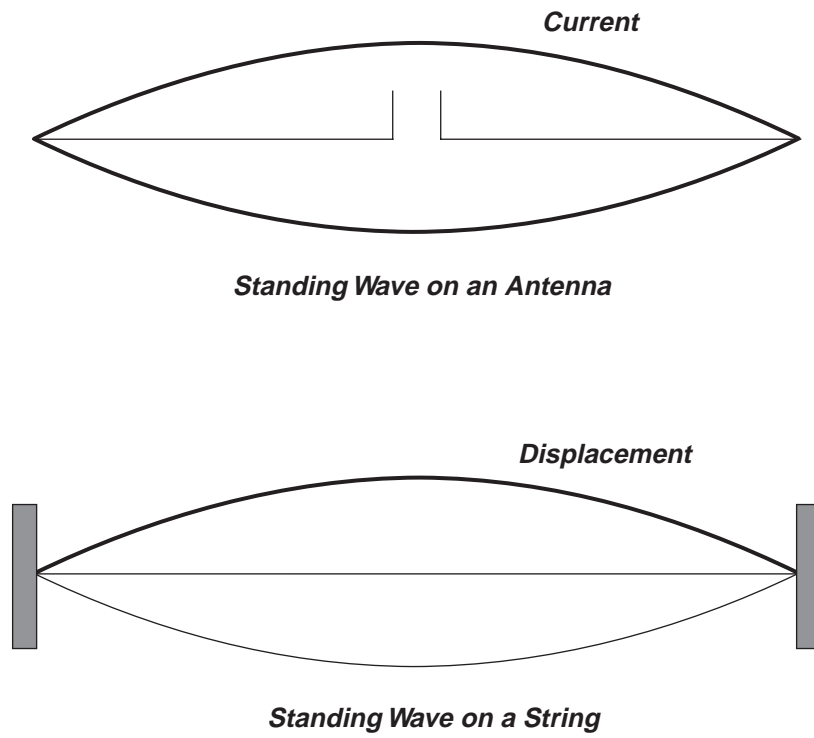

Figure 8.31: Comparison of standing wave on antenna to that of a string.

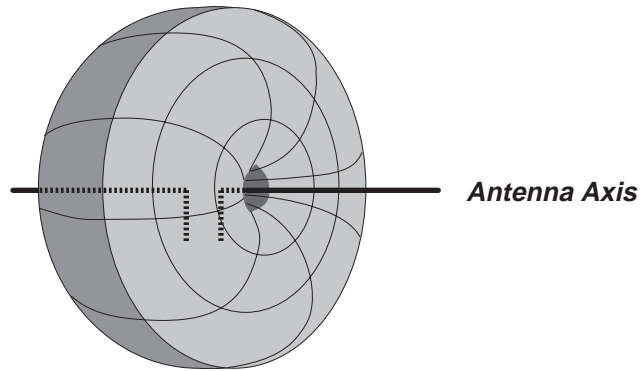

Figure 8.32: Radiation pattern of electric field around half-wave dipole antenna.

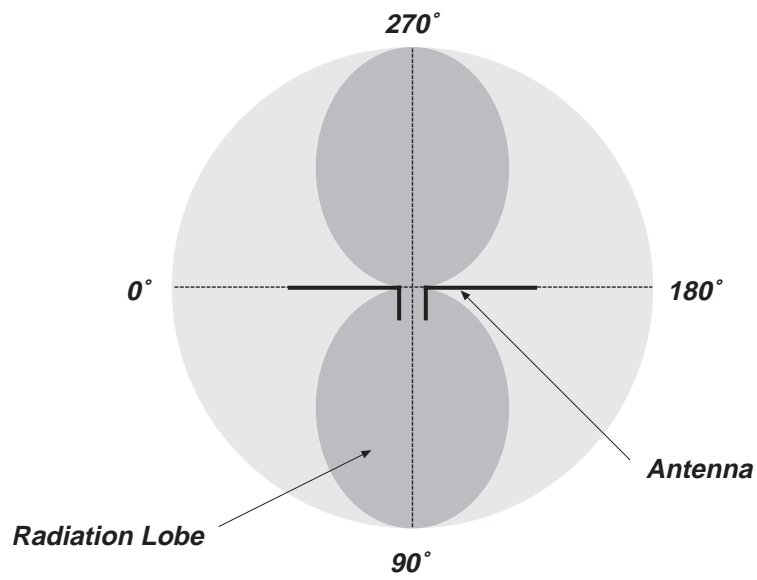

Figure 8.33: Polar graph representation of radiation pattern around half-wave dipolar antenna.

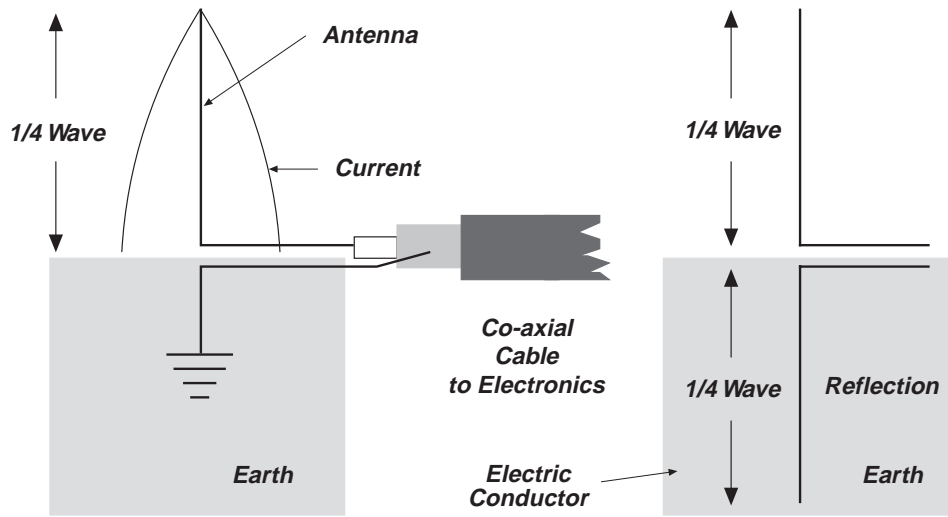

Figure 8.34: Basic elements of a grounded vertical antenna.

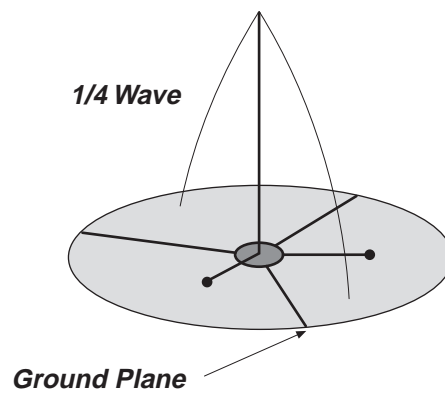

Figure 8.35: Quarter-wave antenna.

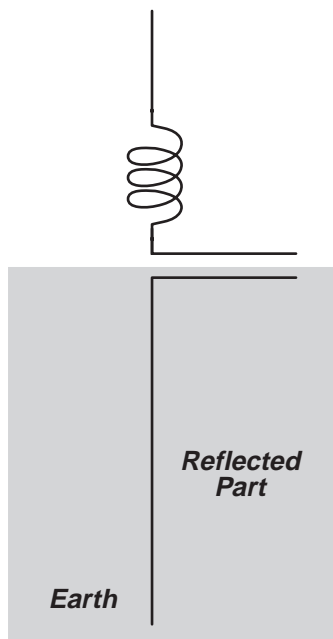

Figure 8.36: Total antenna length is made shorter by inserting a coil in series.

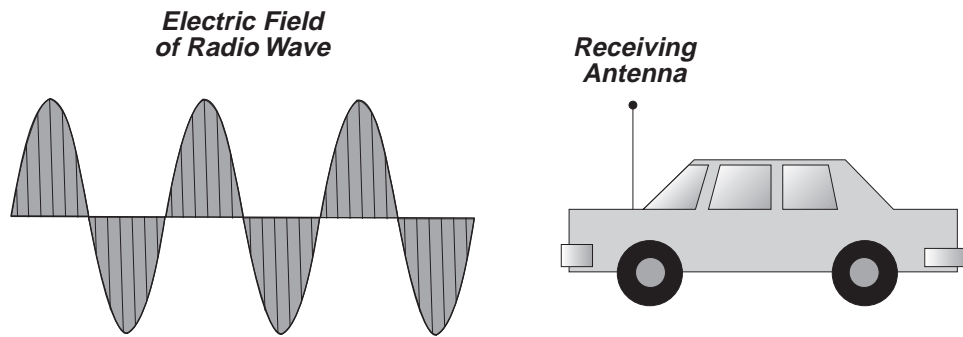

Figure 8.37: When the electric field of radio wave is vertical, the receiving antenna should also be vertical.

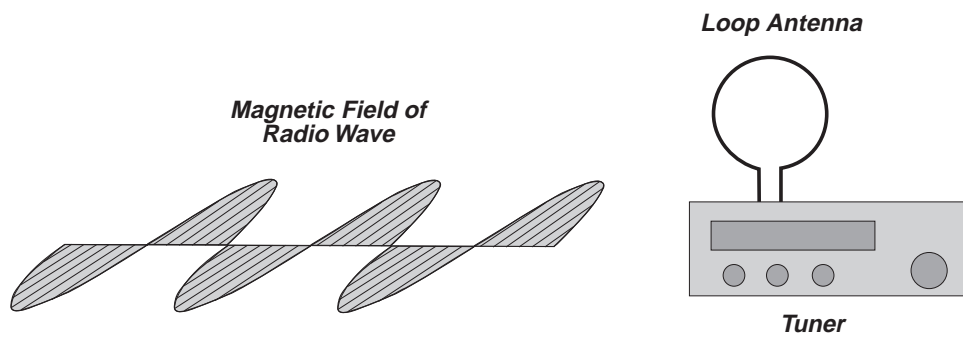

Figure 8.38: Loop antenna detects the magnetic field part of radio wave.

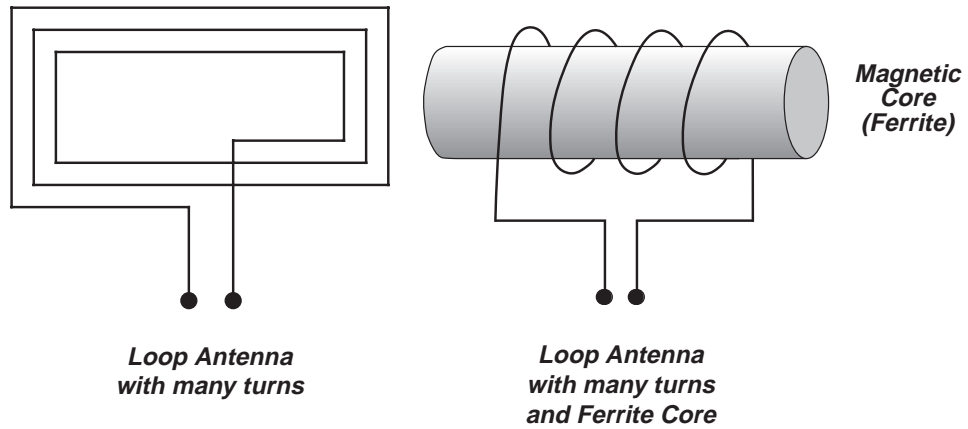

Figure 8.39: Two common loop antennas.

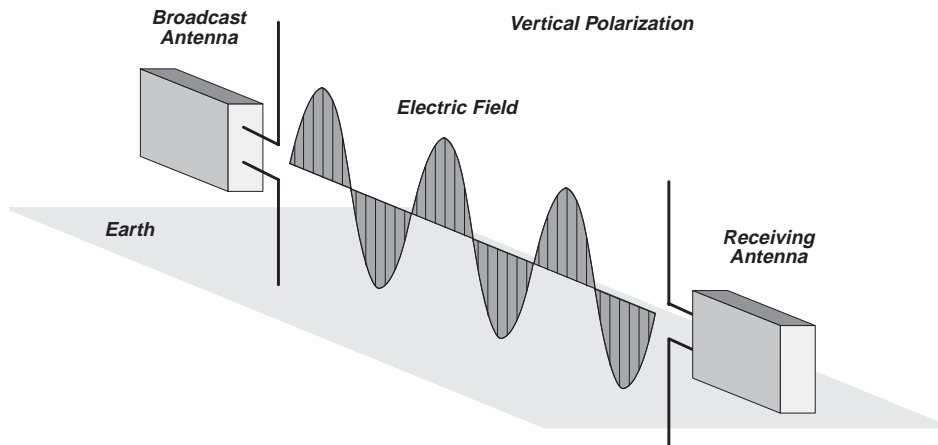

Figure 8.40: Vertically polarized radio wave.

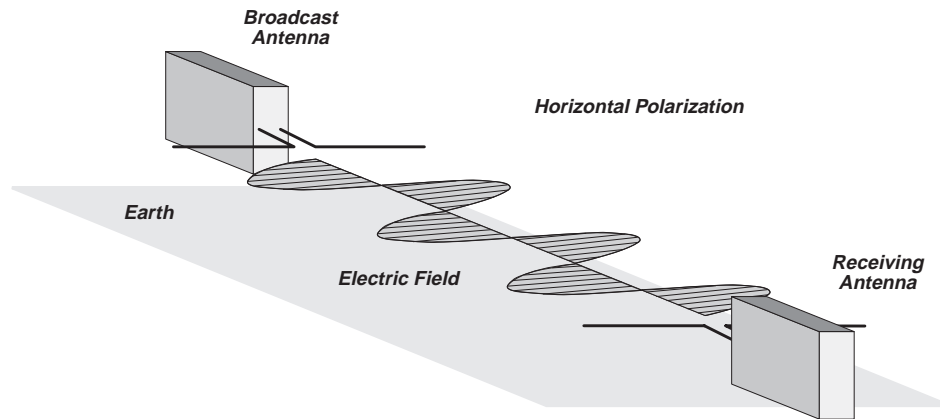

Figure 8.41: Horizontally polarized radio wave.

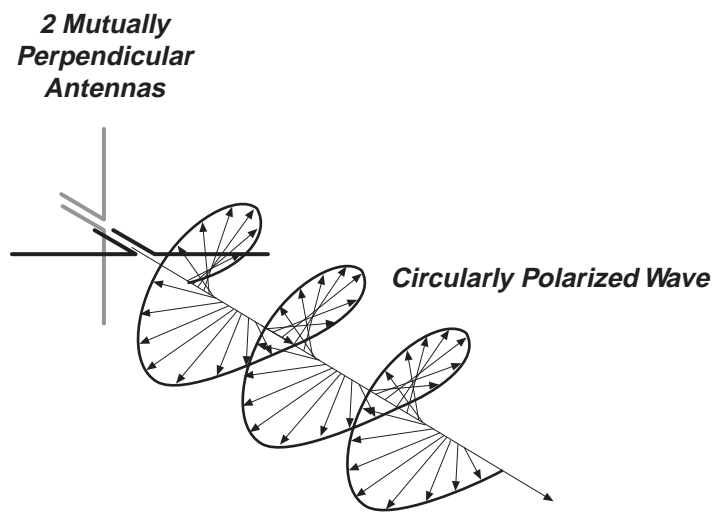

Figure 8.42: Broadcasting with circular polarization.

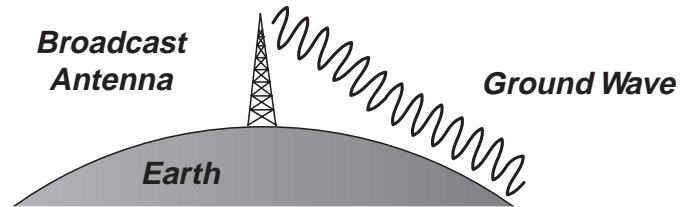

Figure 8.43: Low frequency ground wave follows curvature of earth.

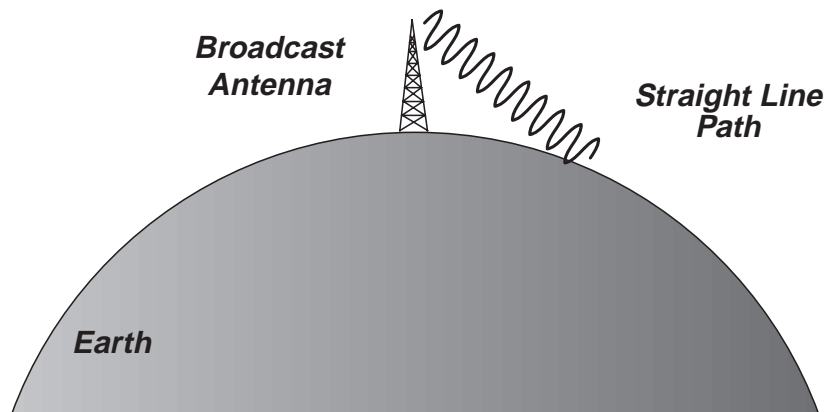

Figure 8.44: Direct (line-of-sight) mode of propagation.

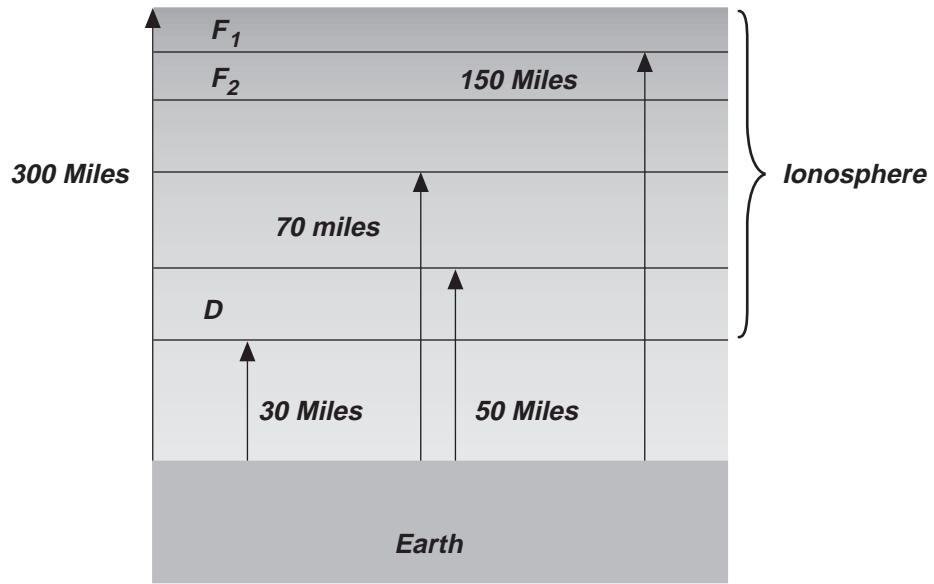

Figure 8.45: Earth's ionosphere layers.

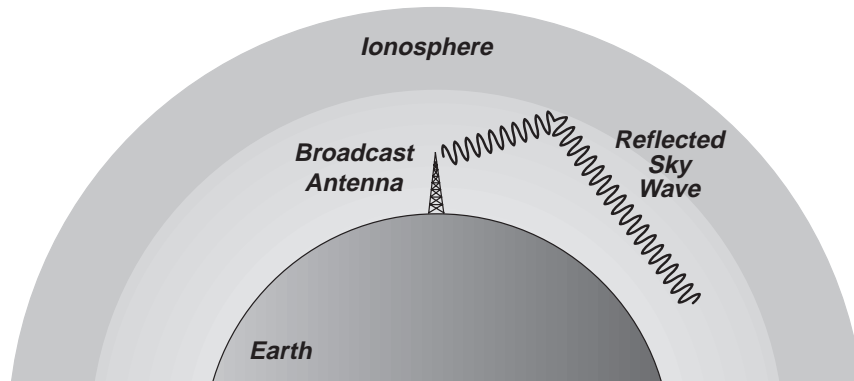

Figure 8.46: Sky wave world communications.

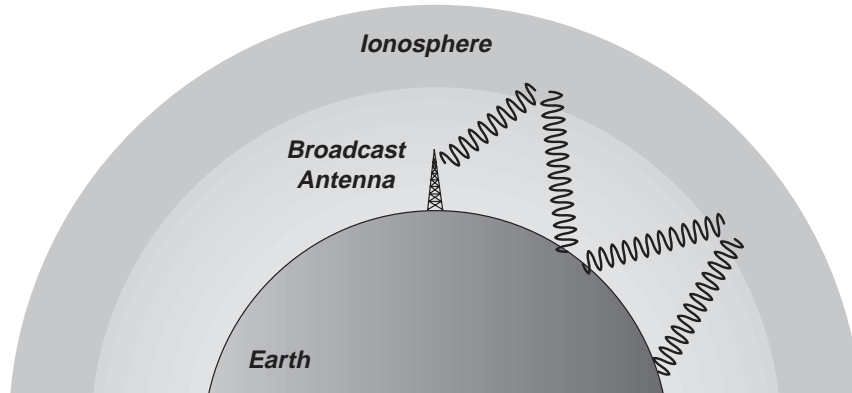

Figure 8.47: Two-hop transmission of radio wave using ionosphere.

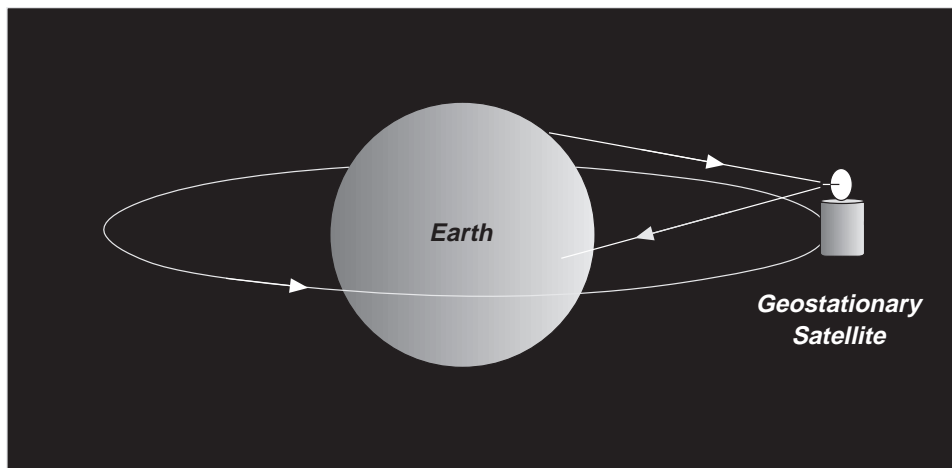

Figure 8.48: Communication using a satellite.

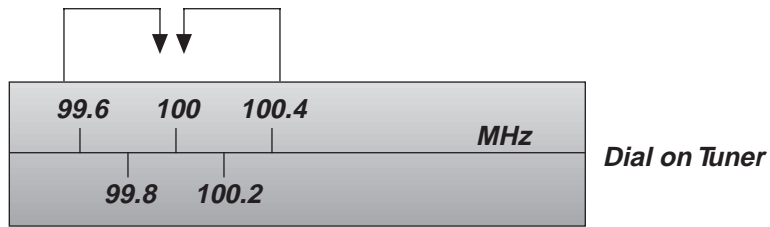

Figure 8.49: Selectivity relates to how well alternate channels are rejected.

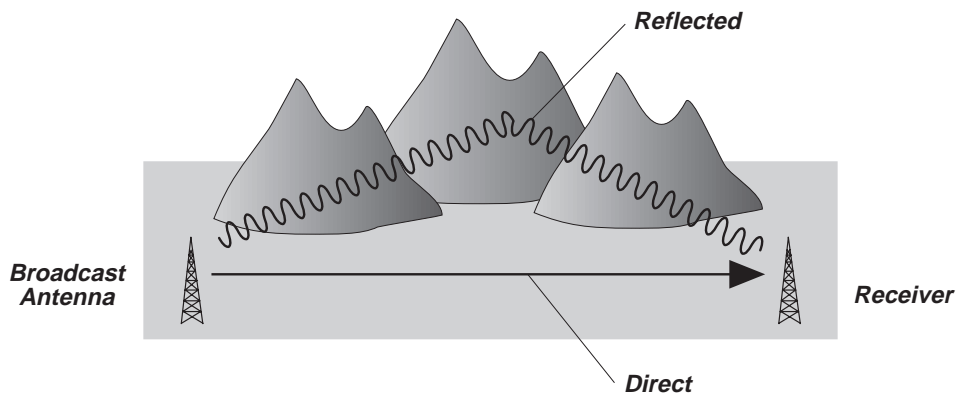

Figure 8.50: Direct and reflected waves from a broadcasting station.

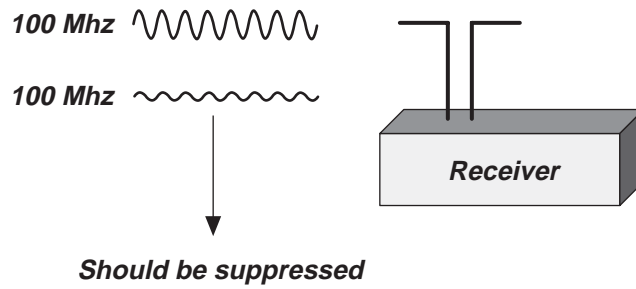

Figure 8.51: Capture ratio in tuner.

Chapter 9

Analog Recording and Playback

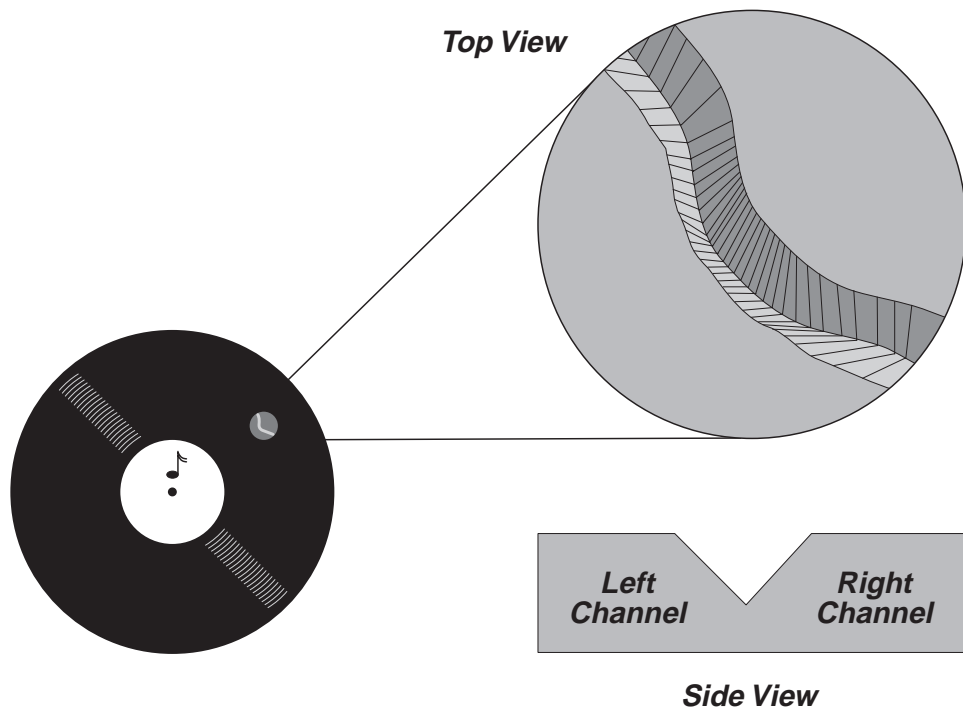

Figure 9.1: Record with grooves representing mechanically engraved waves.

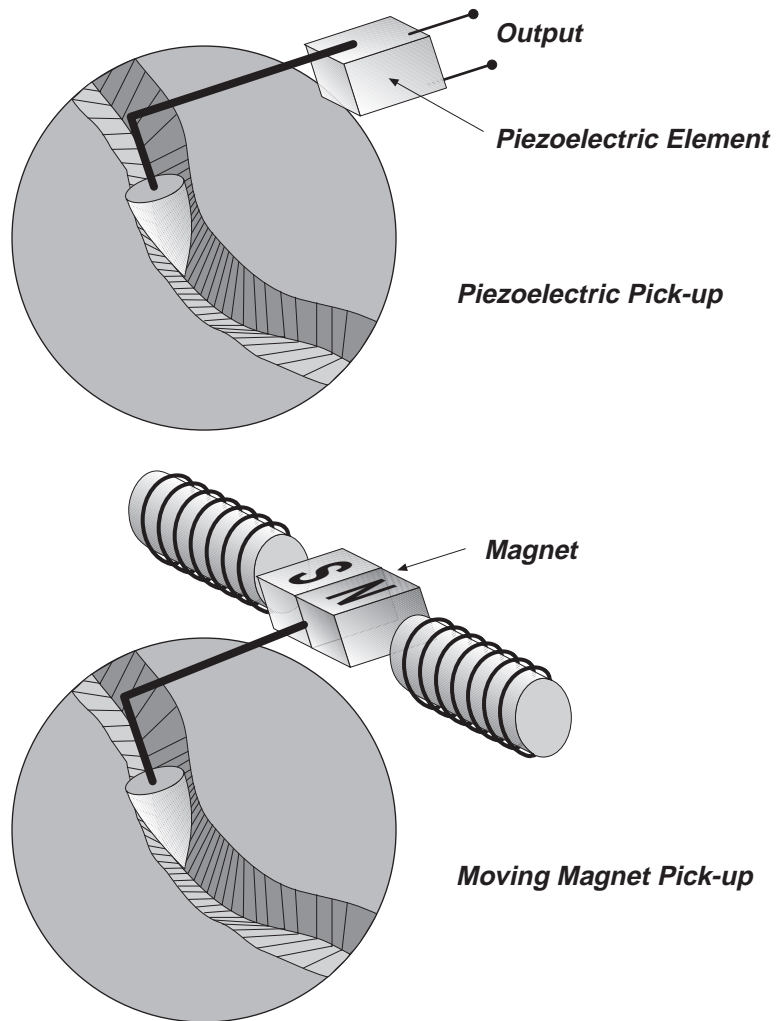

Figure 9.2: Phono playback systems.

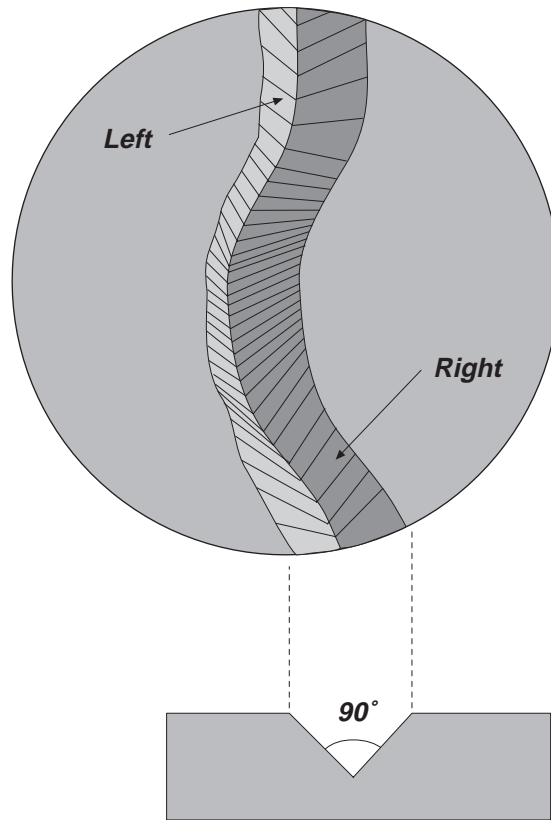

Figure 9.3: Stereo with only one stylus.

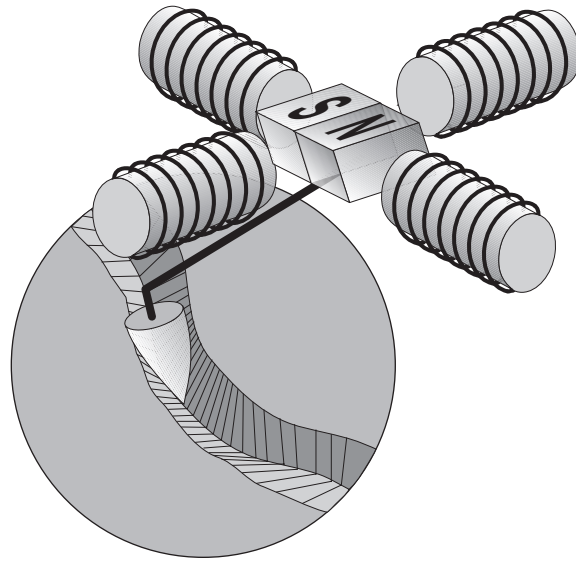

Figure 9.4: A stereo moving magnet phono cartridge.

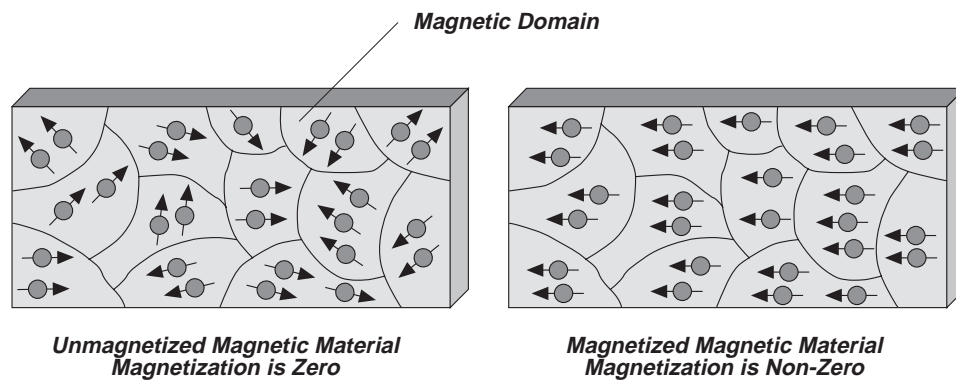

Figure 9.5: Unmagnetized and magnetized magnetic material.

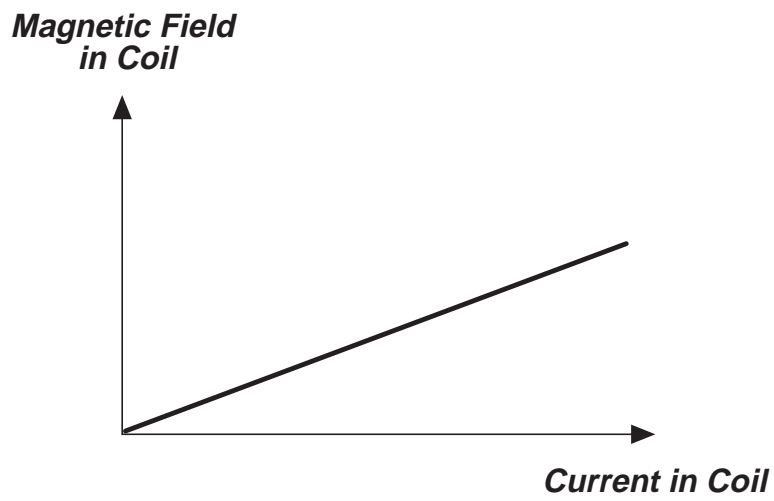
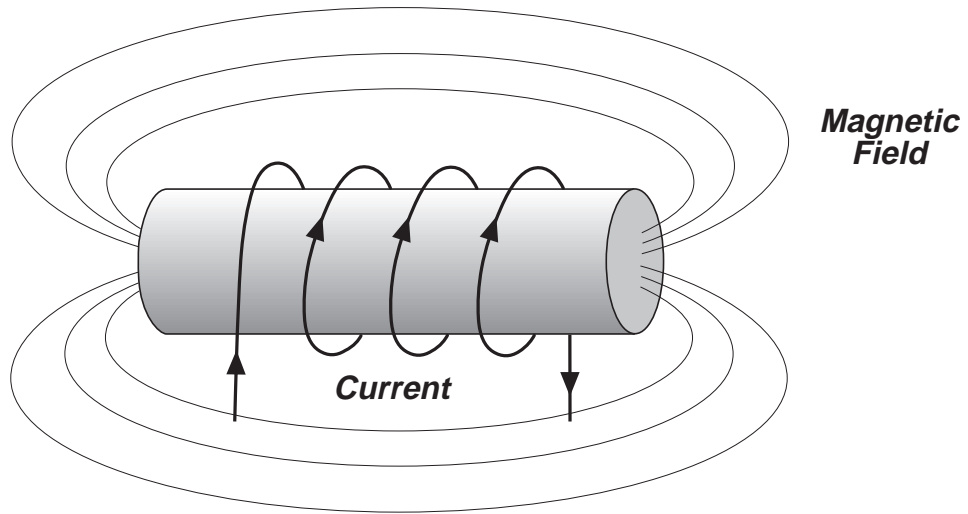

Figure 9.6: Magnetic field produced by a coil when current flows through it.

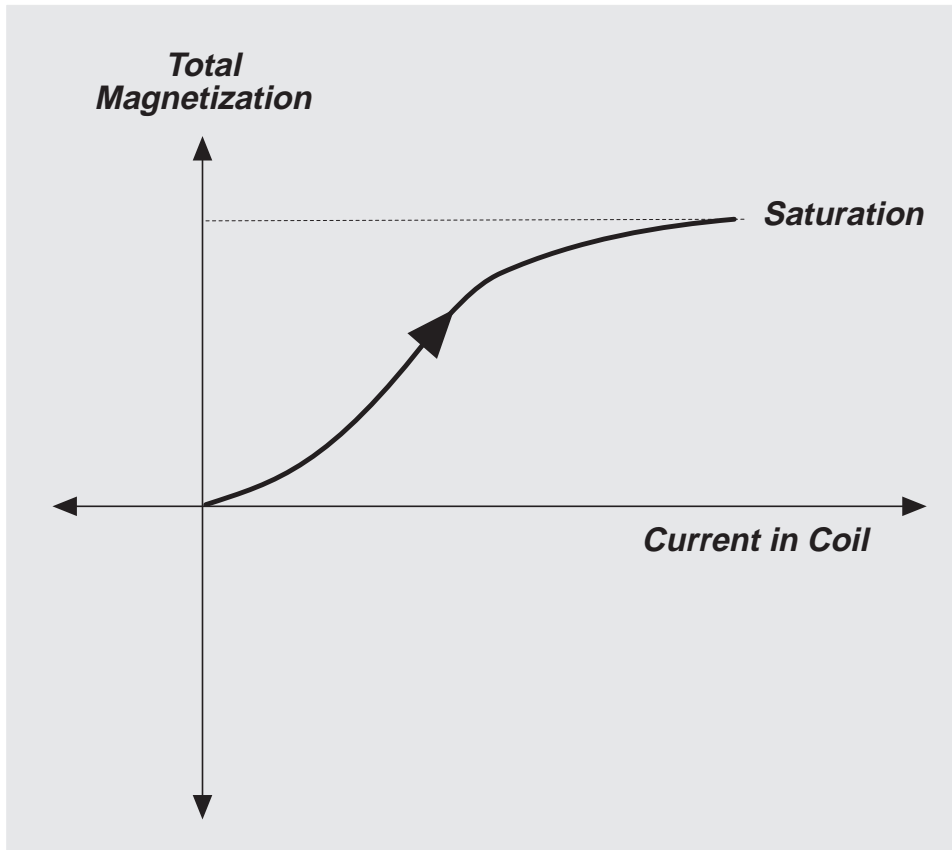

Figure 9.7: Alignment of domains in a magnetic material.

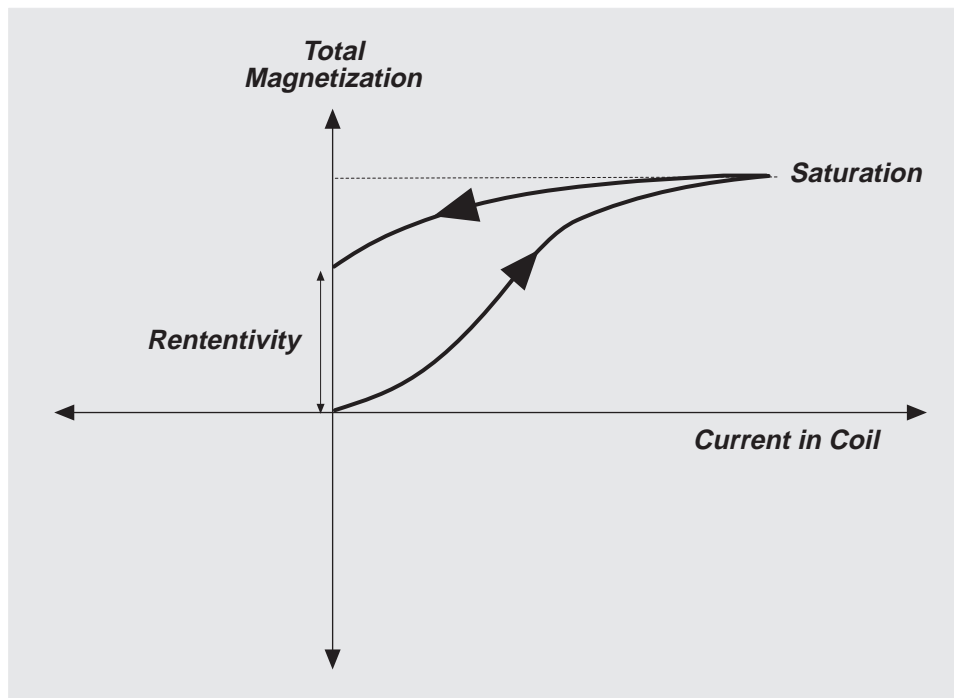

Figure 9.8: Behavior of magnetic material in a coil whose current is increased and decreased to zero.

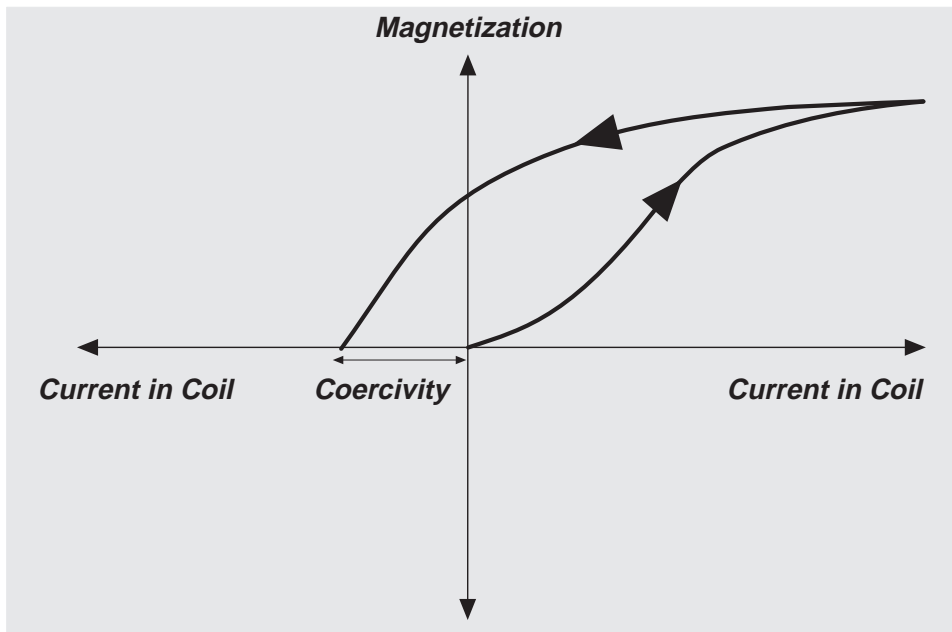

Figure 9.9: Memory is destroyed by reversed current in coil.

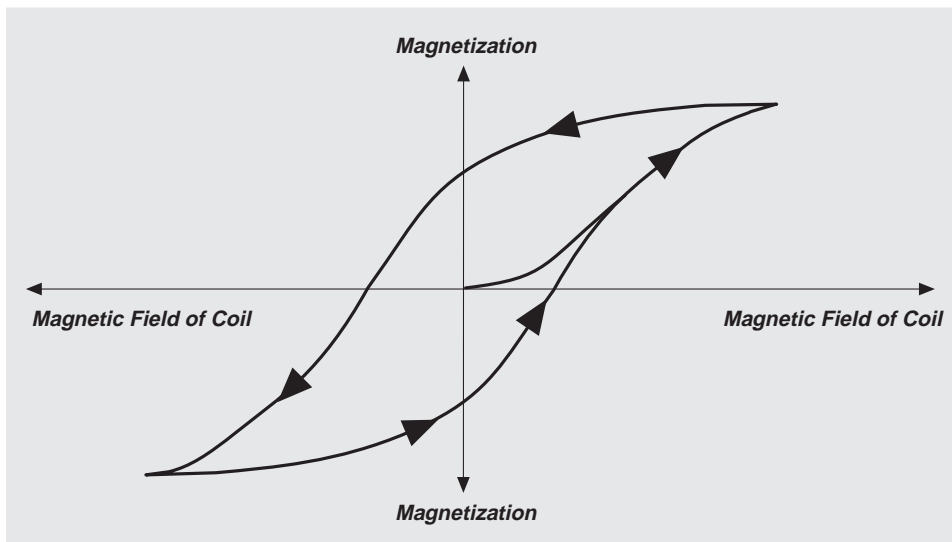

Figure 9.10: Hysteresis curve of magnetic material.

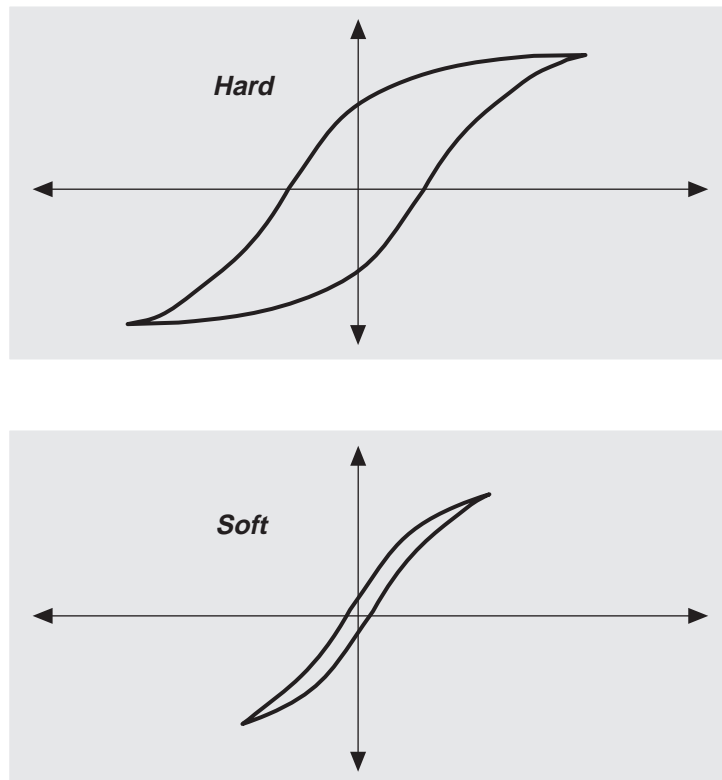

Figure 9.11: Groups of magnetic materials.

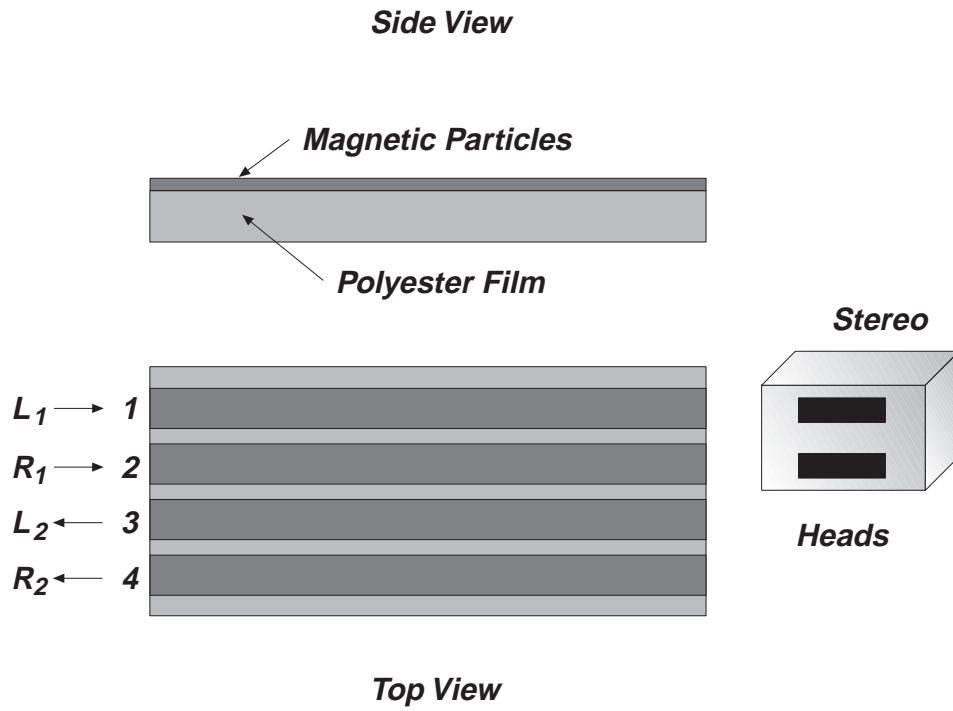

Figure 9.12: Side and top views of magnetic tape.

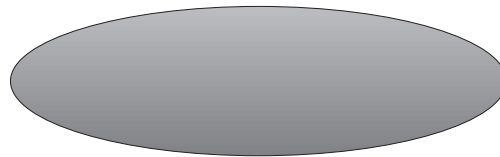

Figure 9.13: Magnetic particle of gamma – Iron (III) Oxide as used on tapes.

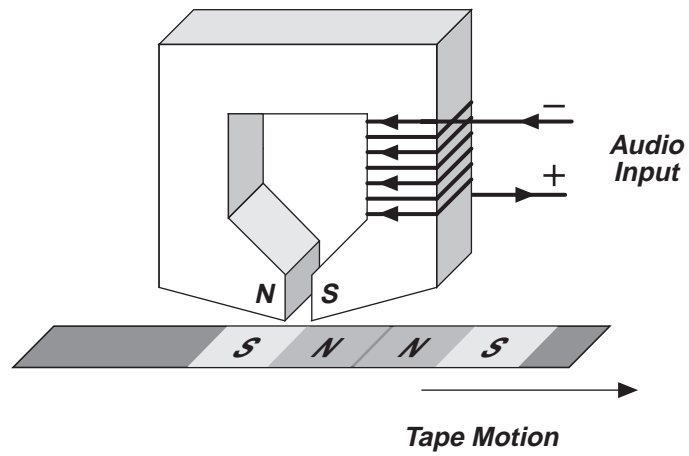

Figure 9.14: Recording head aligning magnetic domains on tape.

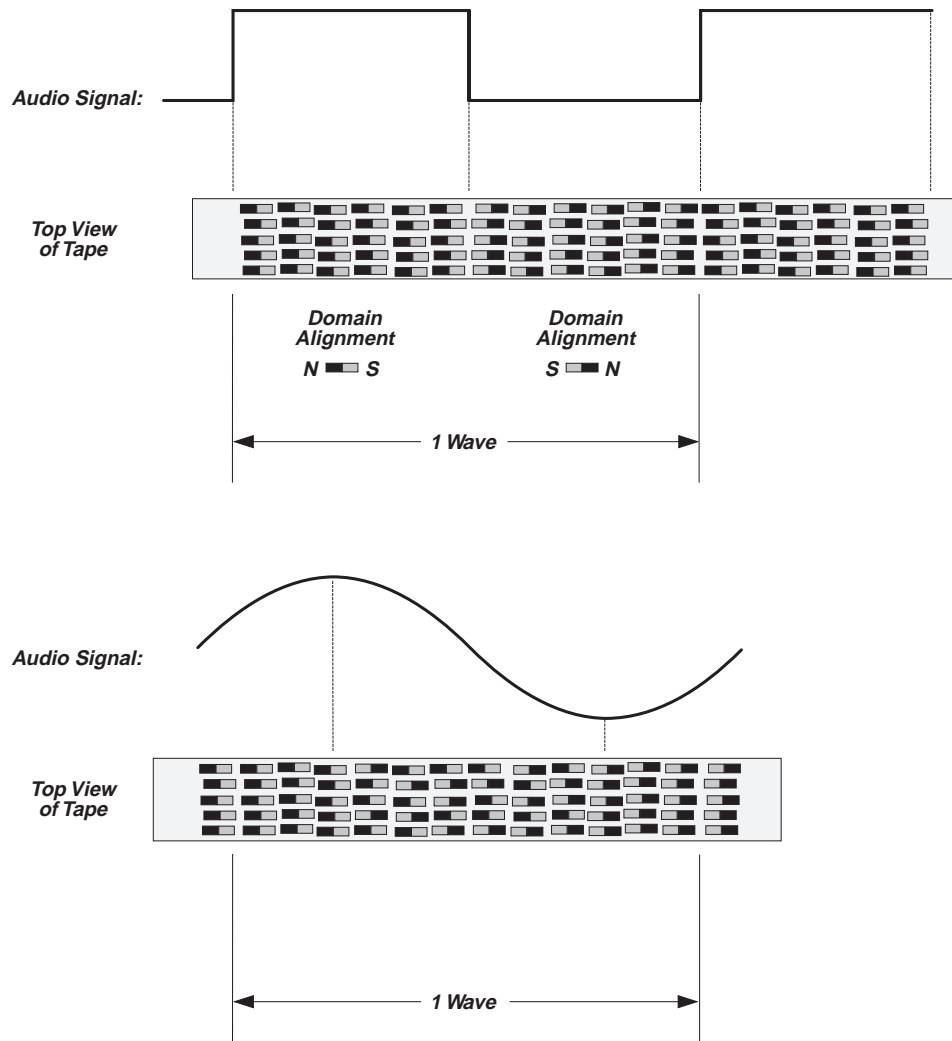

Figure 9.15: Analog recording on a magnetic tape.



Figure 9.16: Recorded information on magnetic tape.

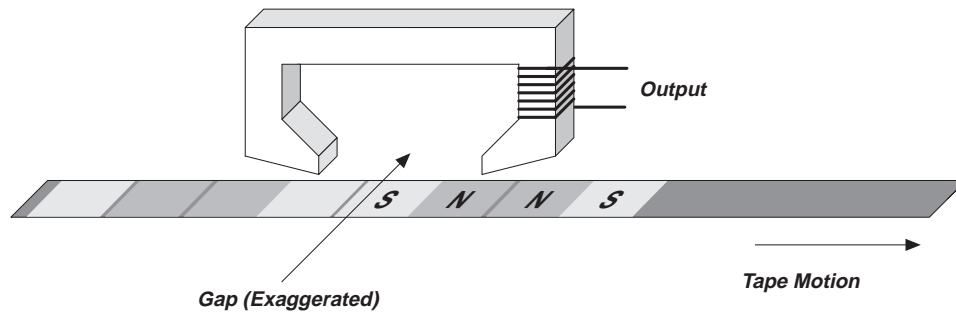

Figure 9.17: Playback head for reading information on a tape.

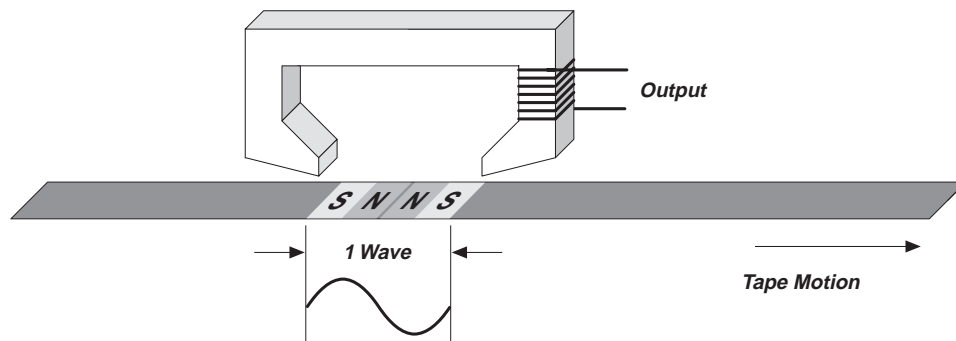

Figure 9.18: Playback head reading signals.

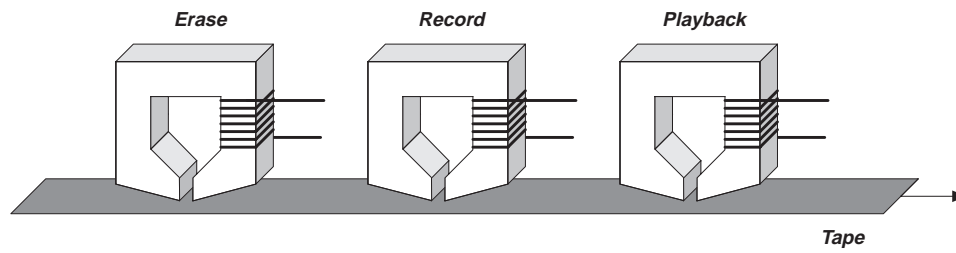

Figure 9.19: Order of heads on a tape deck.

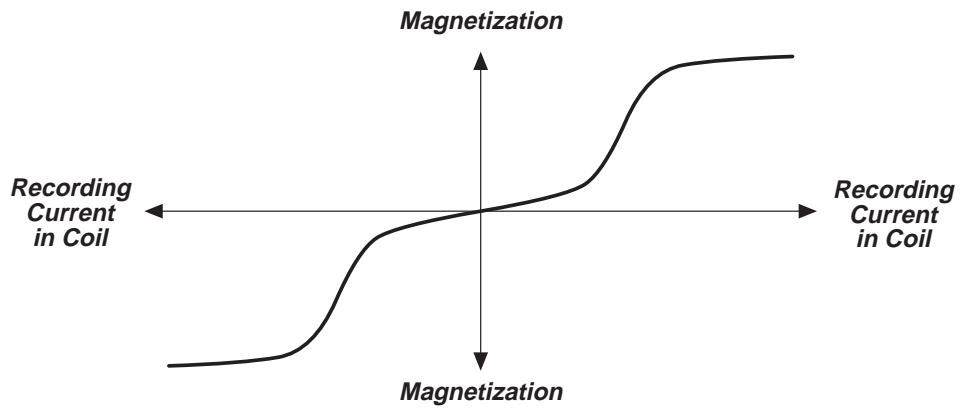

Figure 9.20: Recording on material with magnetic hysteresis.

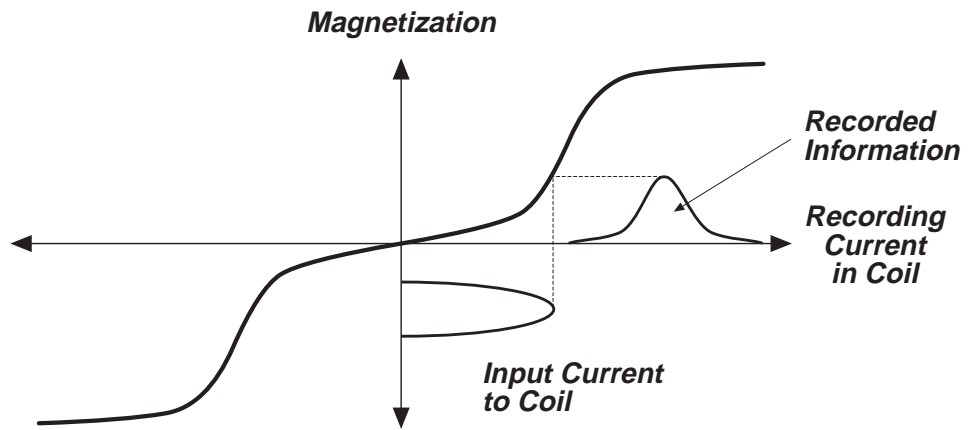

Figure 9.21: Recording a signal on a tape.

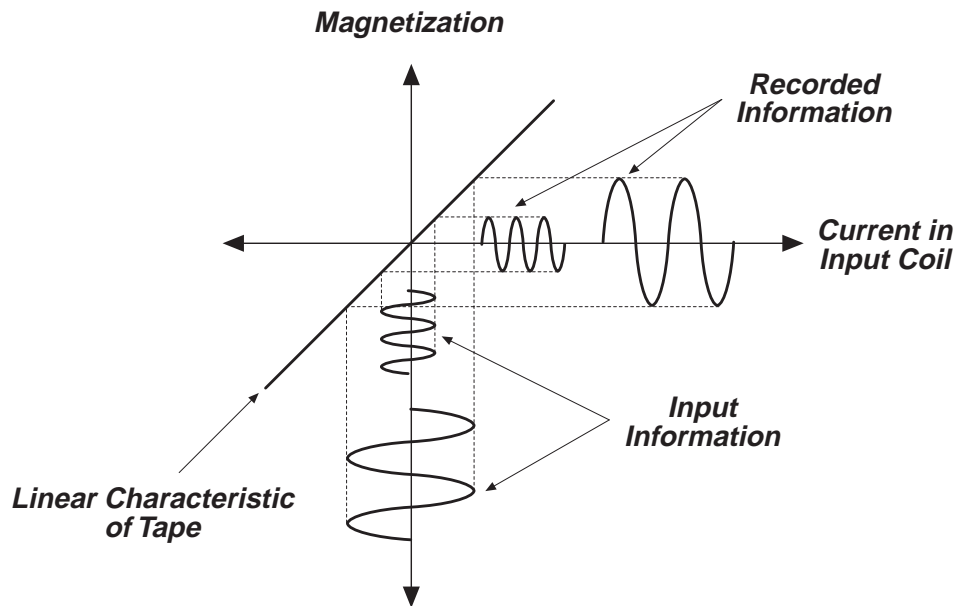

Figure 9.22: Ideal magnetic characteristics for tape — linear behavior.

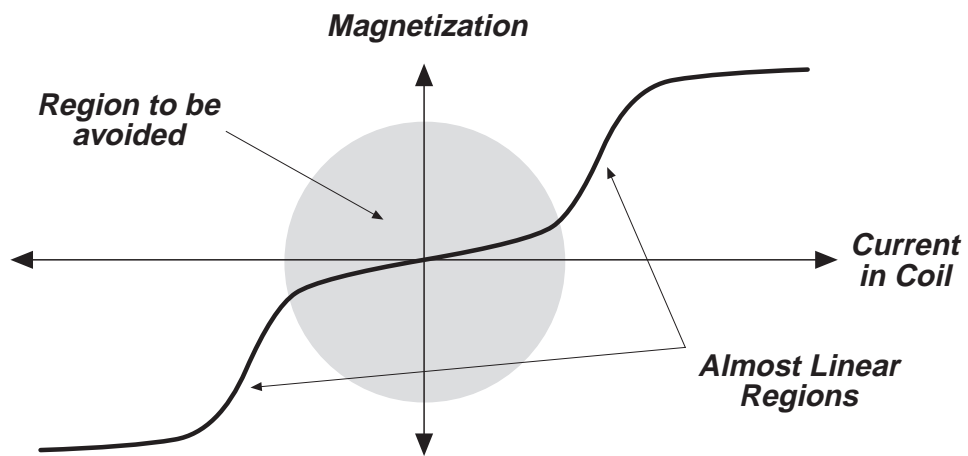

Figure 9.23: Useful region on hysteresis curve for magnetic recording.

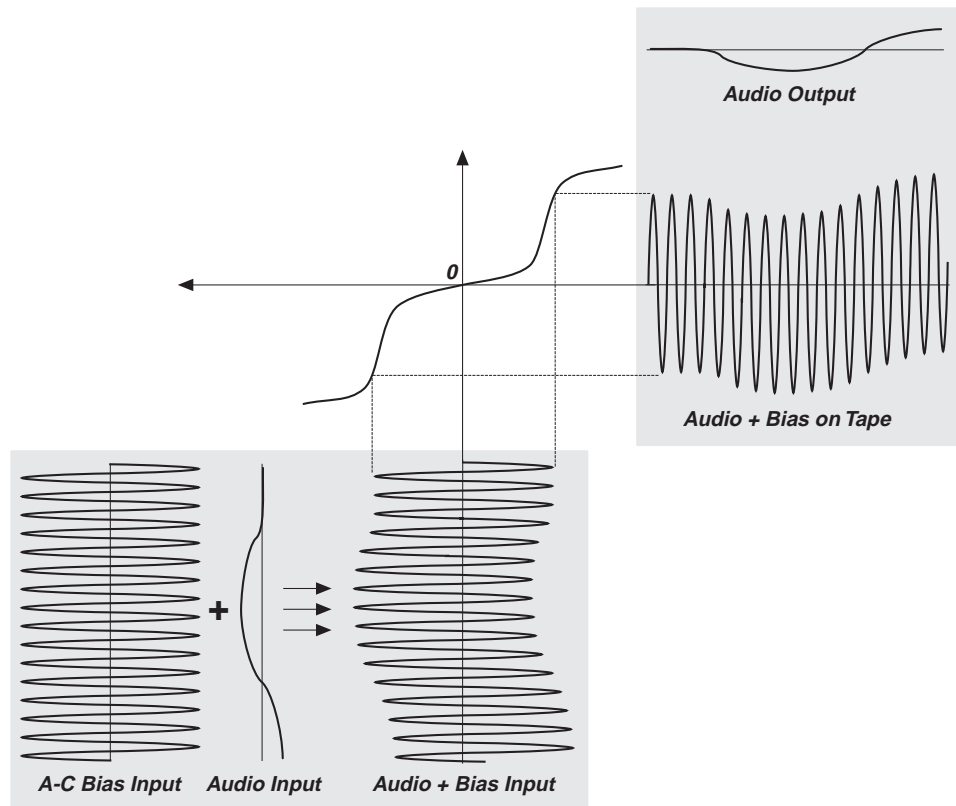

Figure 9.24: Recording on magnetic tape with bias.

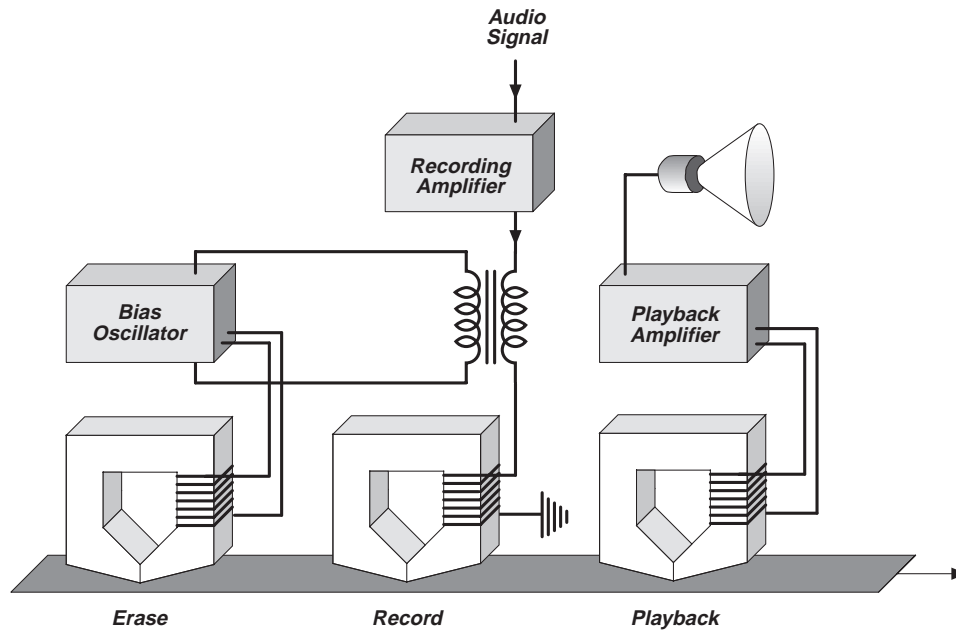

Figure 9.25: Details of heads for magnetic recording.

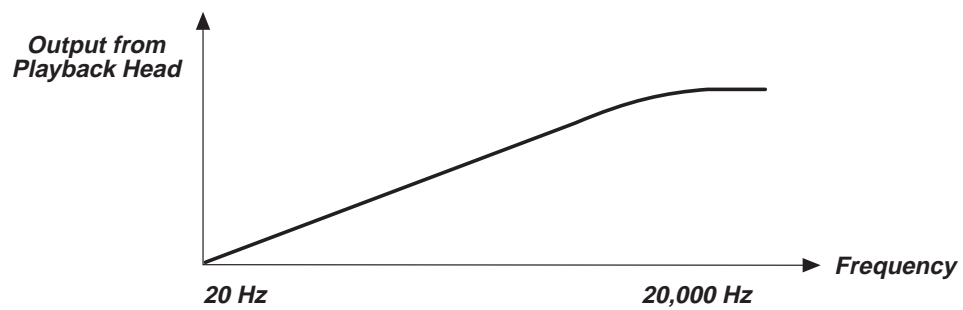

Figure 9.26: Frequency dependence of output from playback head.

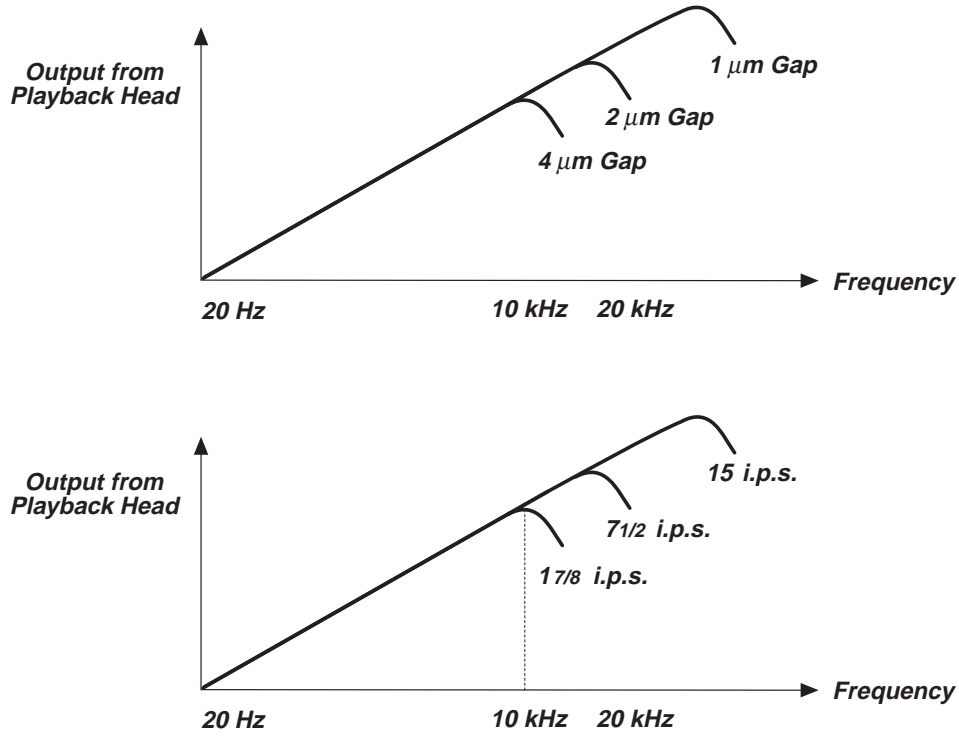

Figure 9.27: Output from playback head as a function of frequency for various gap sizes and tape speeds.

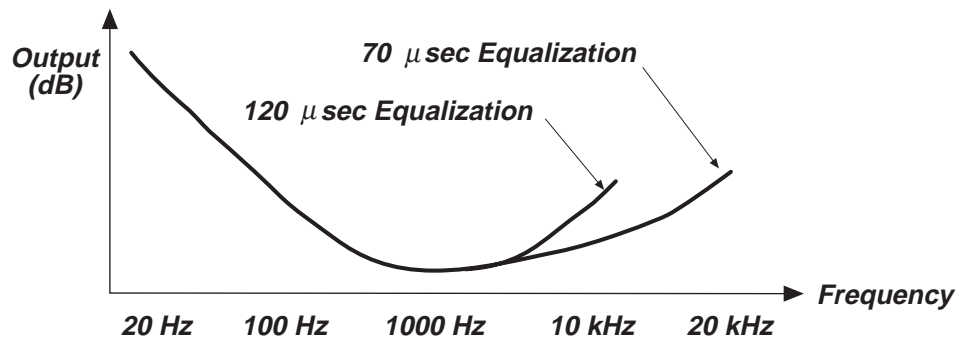

Figure 9.28: Equalization in playback.

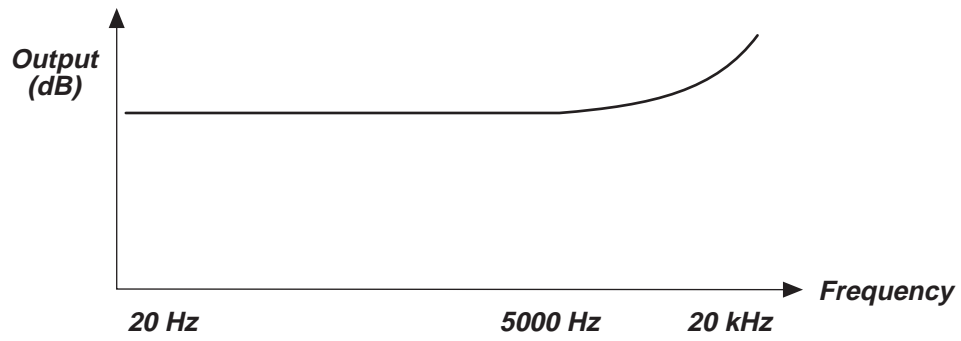

Figure 9.29: Equalization in recording.

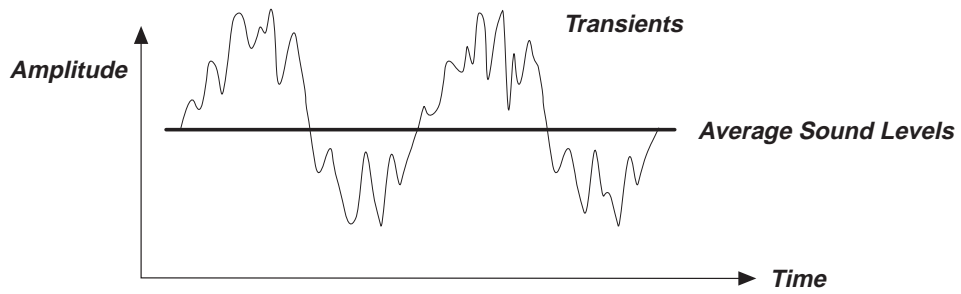

Figure 9.30: Typical musical spectrum.

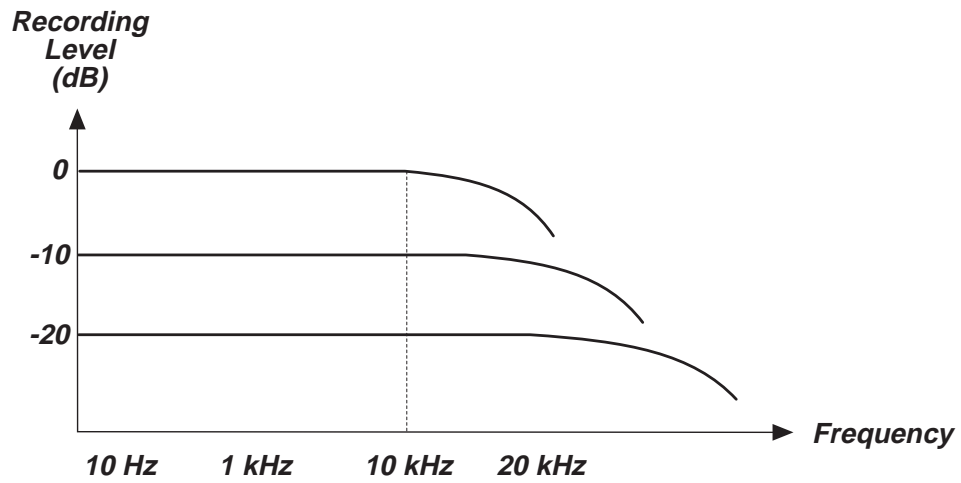

Figure 9.31: Frequency response at different recording levels.

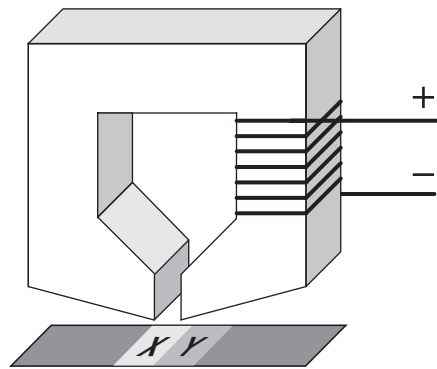

Figure 9.32: Exercise 9.4.

Chapter 10

Digital Optical Recording & Playback

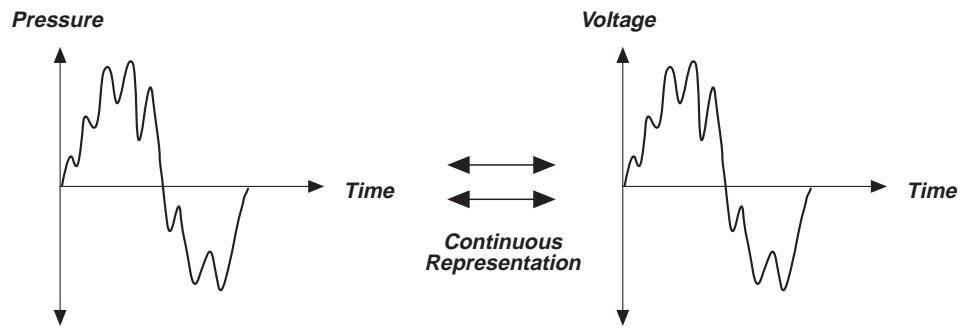

Figure 10.1: Sound wave and its analog representation as a voltage.

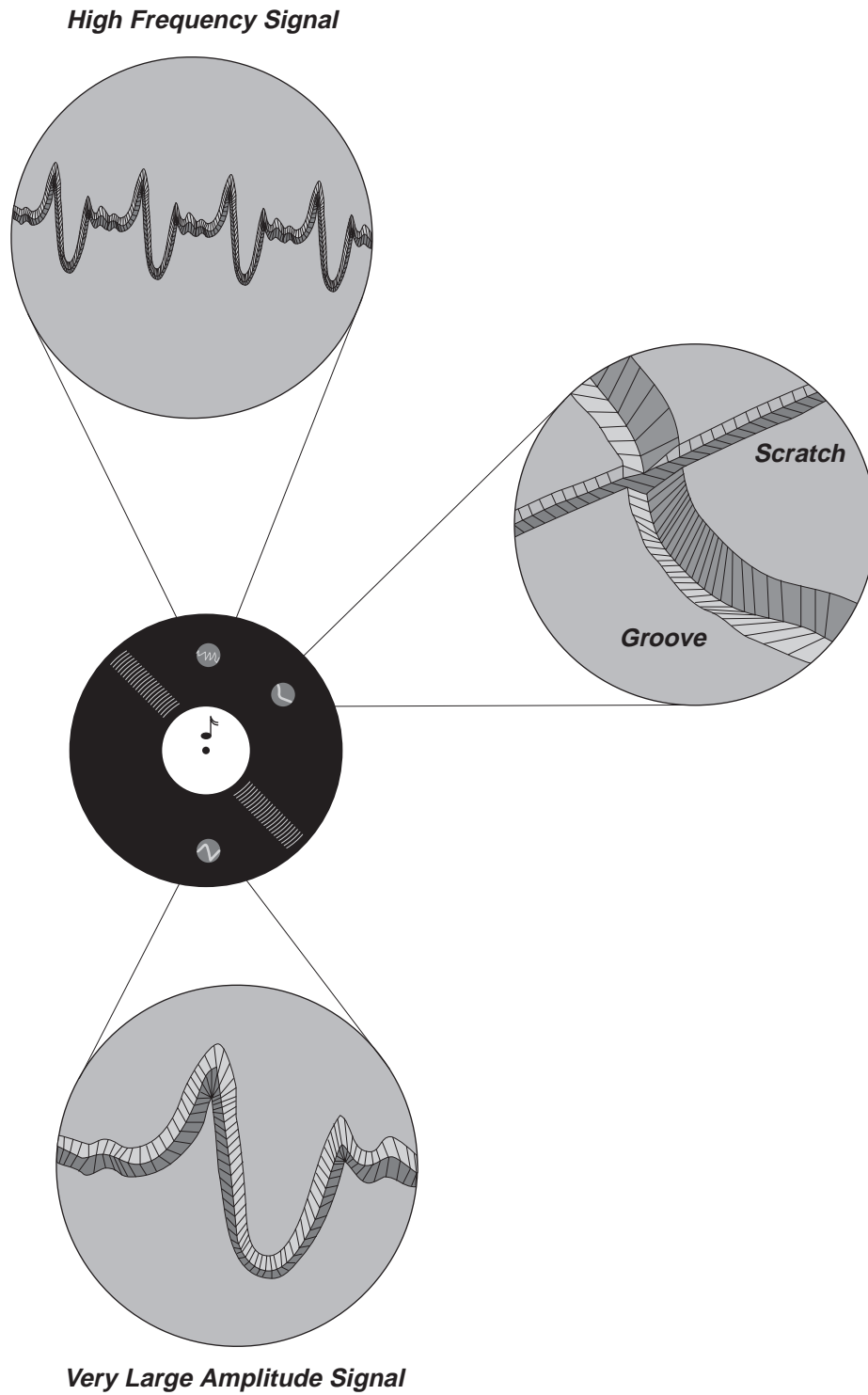

Figure 10.2: Grooves on a record representing analog signals.

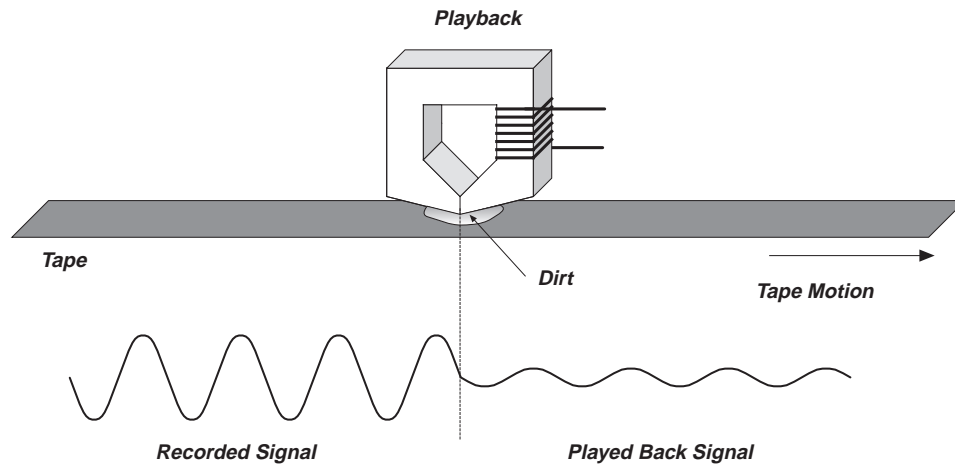

Figure 10.3: Distortion of analog signal by dirt stuck between playback head and tape.

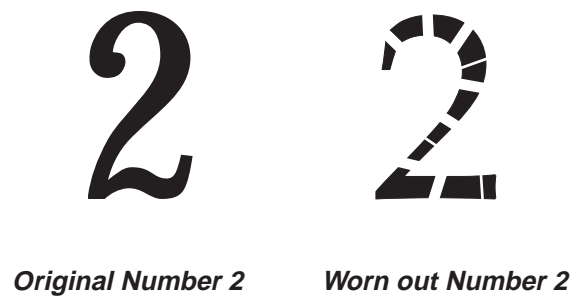

Figure 10.4: Original number 2 and worn out number 2; basic information is not lost when number is worn out.

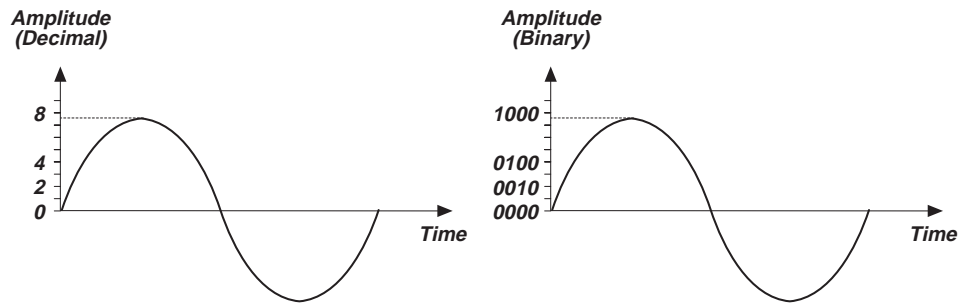

Figure 10.5: (a) Analog signal, decimal scale (b) Analog signal, binary scale.

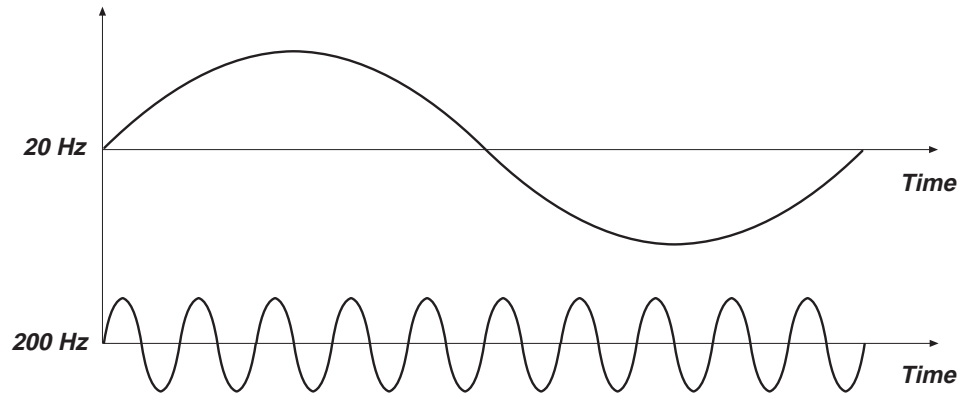

Figure 10.6: 20 Hz wave will get more samples per wave than a 200 Hz wave.

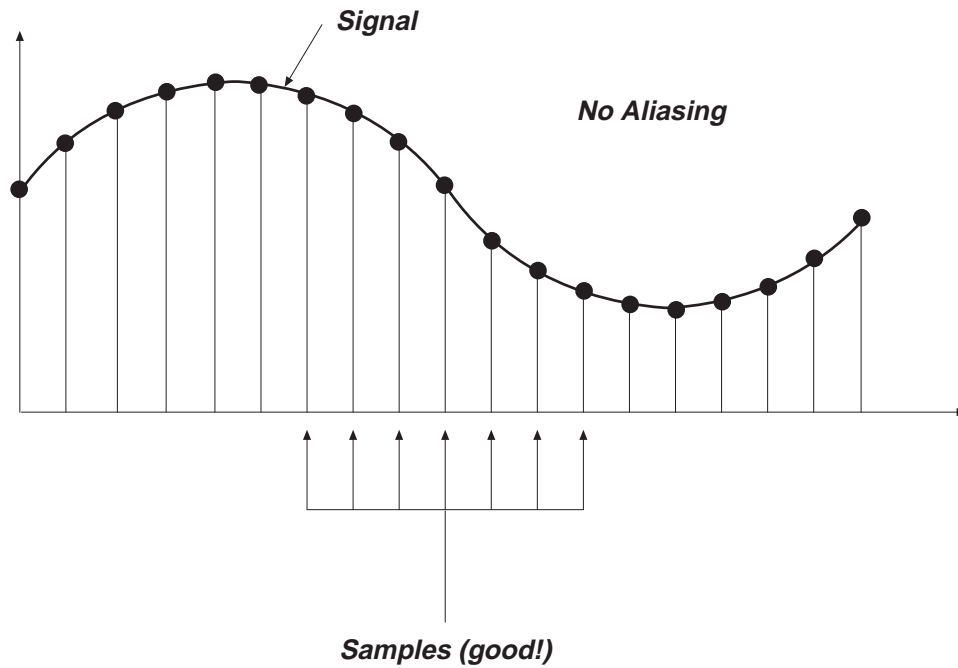
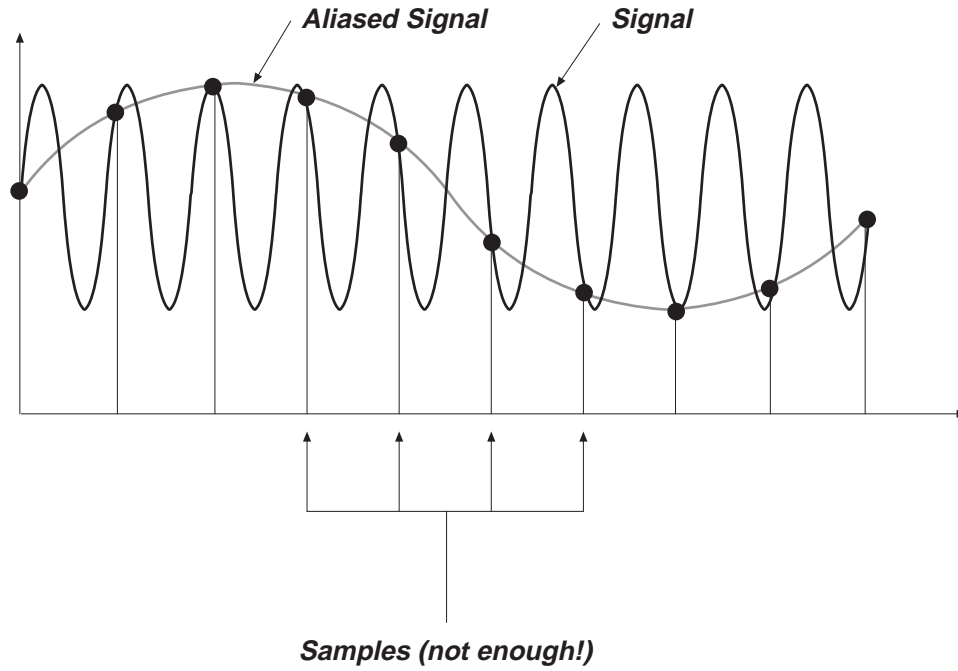

Figure 10.7: Aliasing due to inadequate sampling rate.

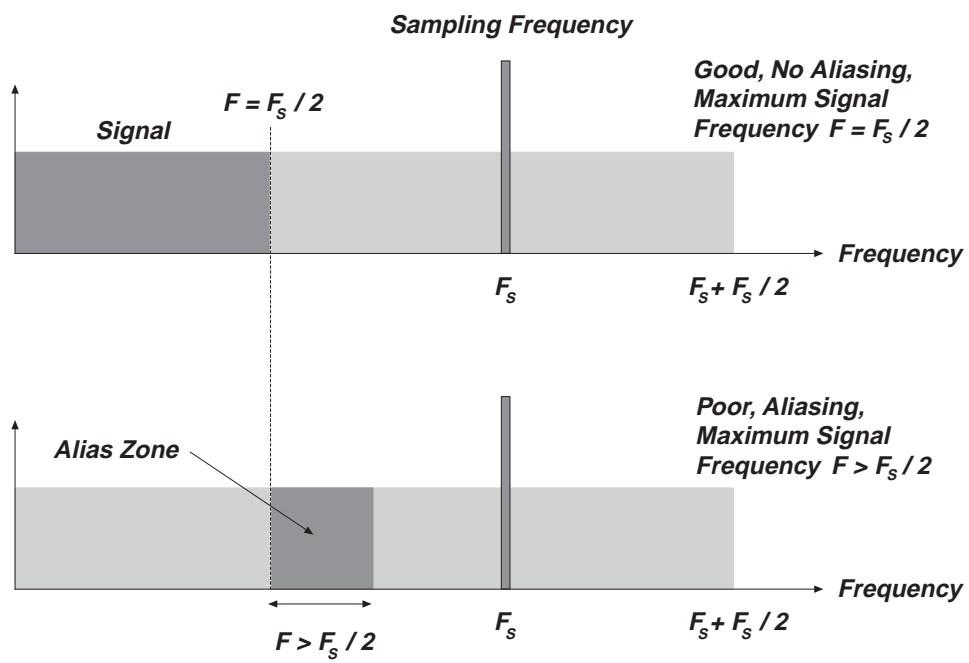

Figure 10.8: Audio spectrum and sideband frequencies due to sampling.

Sample and Hold of Analog Signal

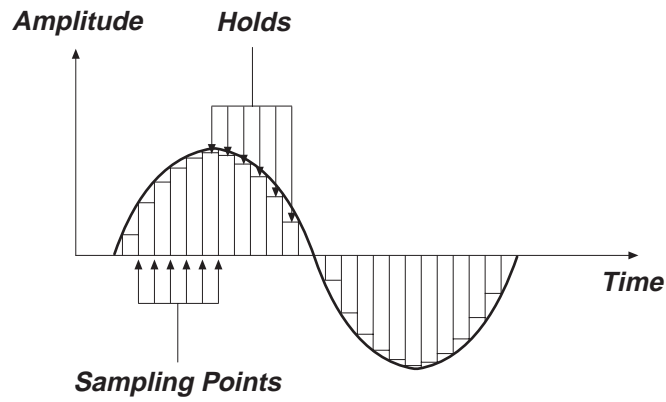

Figure 10.9: Sample and hold of a signal for digitizing.

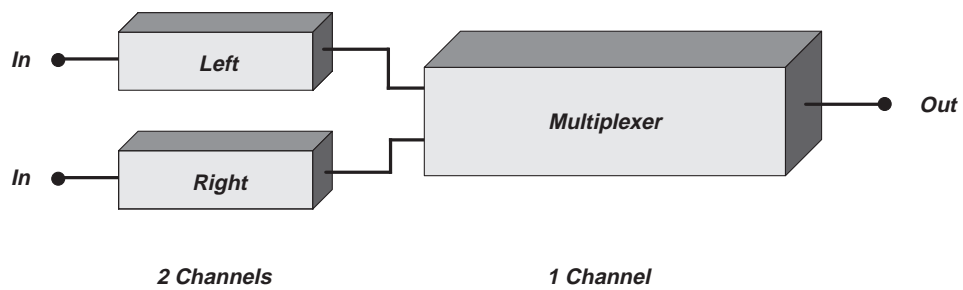

Figure 10.10: Multiplexing of left and right channels.

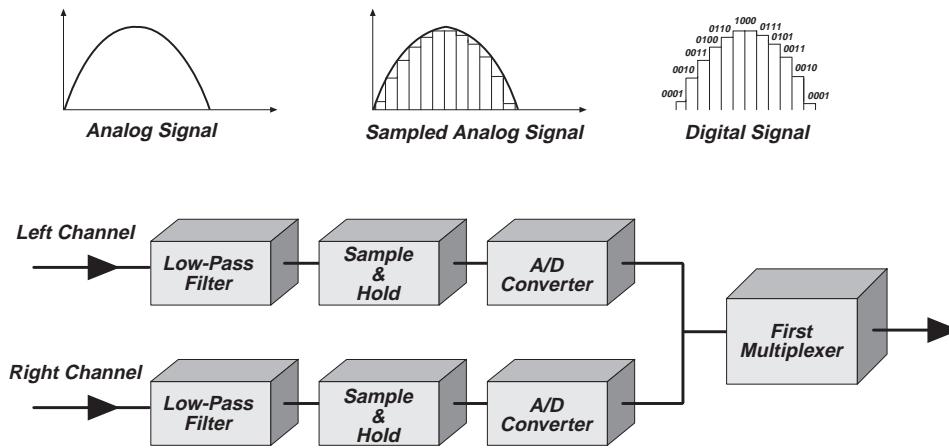

Figure 10.11: Digitizing a signal.

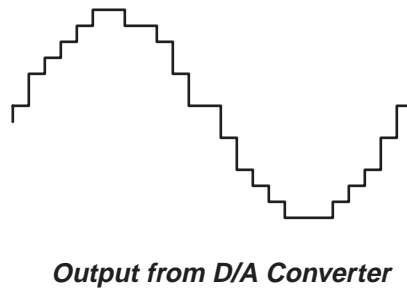

Figure 10.12: Output of D-A converter.

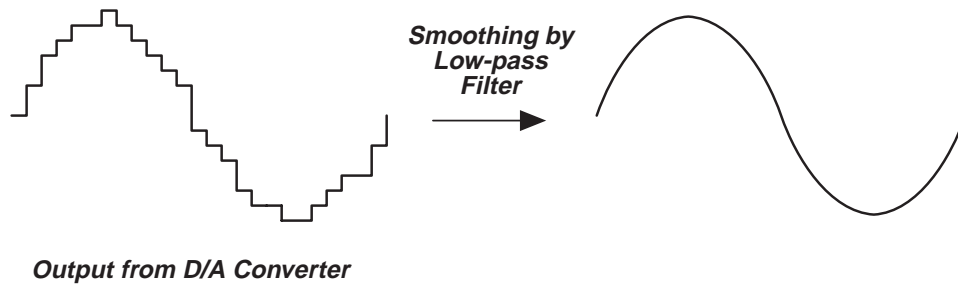

Figure 10.13: Output of low-pass filter.

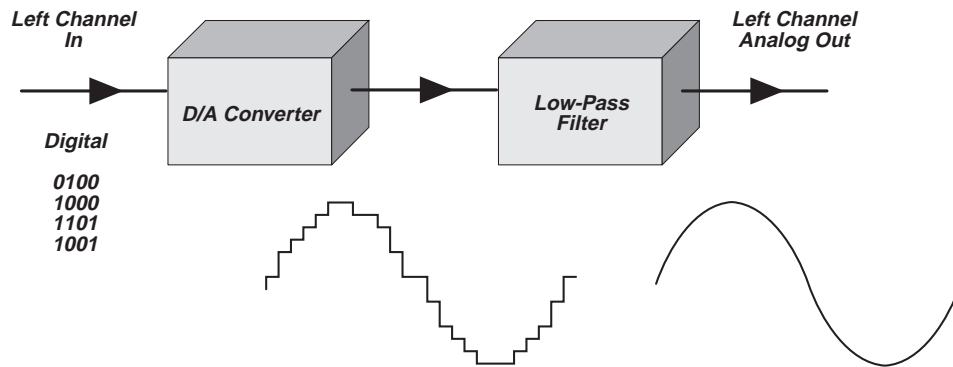

Figure 10.14: Main features of playback of digital signal.

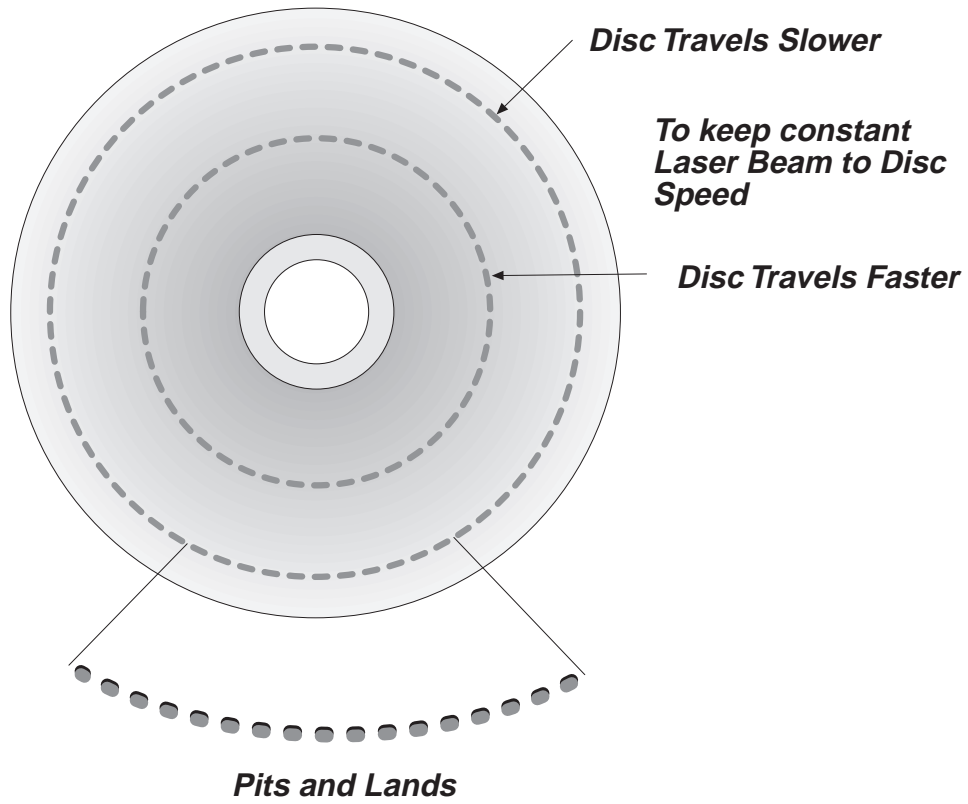

Figure 10.15: Details of information on a CD.

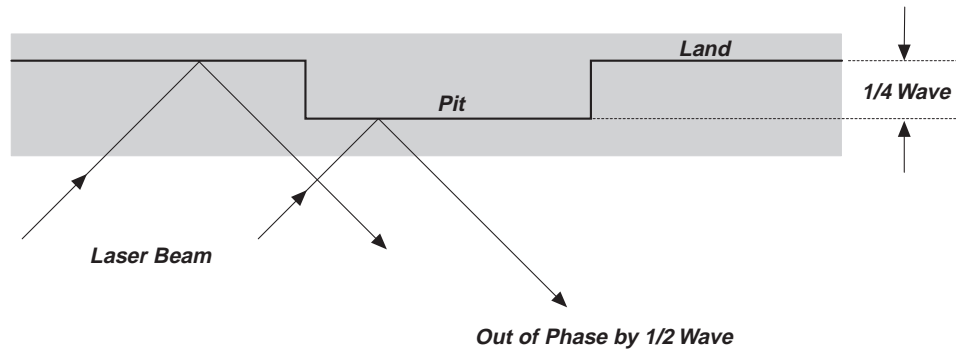

Figure 10.16: Interference between light beam reflected from pit and from flat.

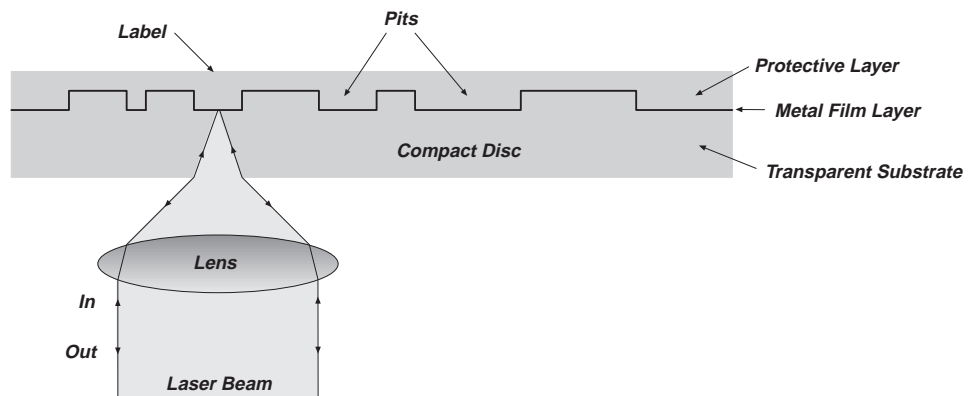

Figure 10.17: Focusing action of a laser beam by lens.

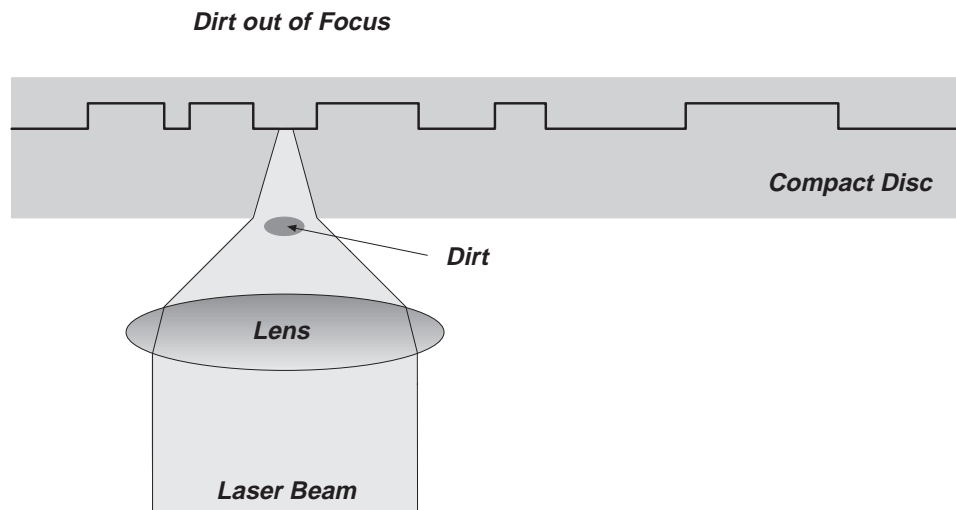

Figure 10.18: Reduced effect of surface defect on CD.

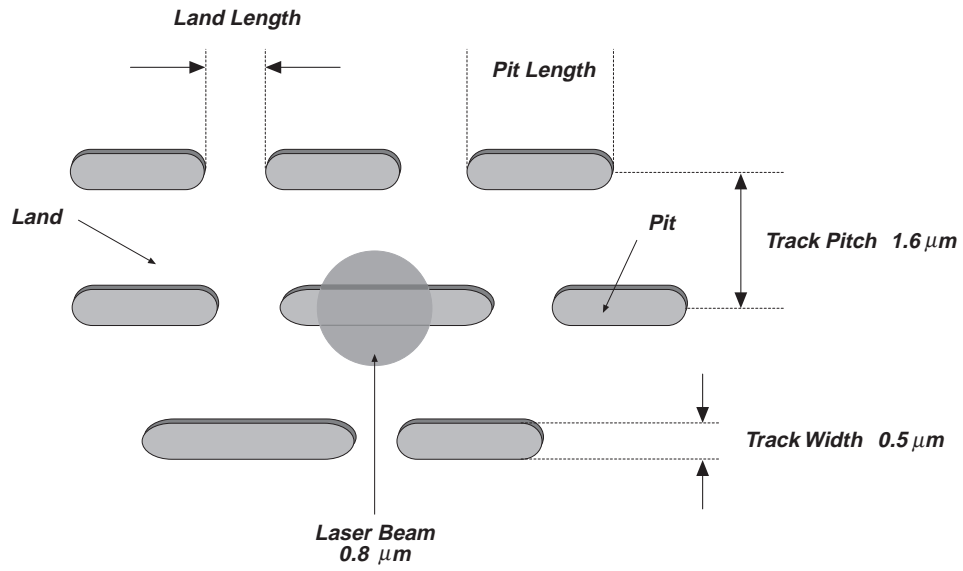

Figure 10.19: Laser spot focused on disc data.

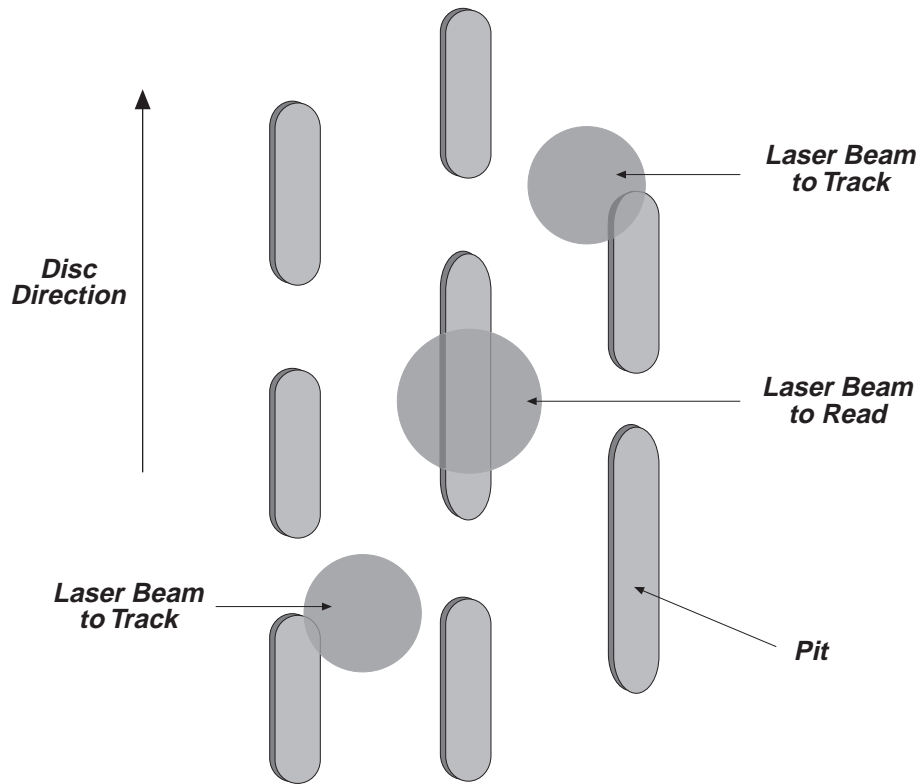

Figure 10.20: Three-beam detection; one for read-out and two beams for tracking.

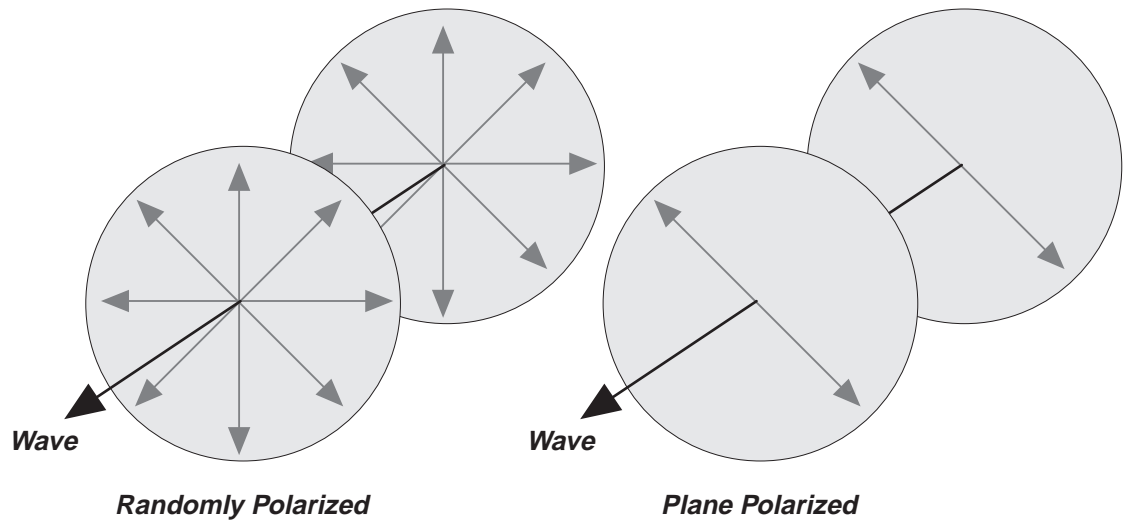

Figure 10.21: Randomly polarized beam and plane-polarized beam.

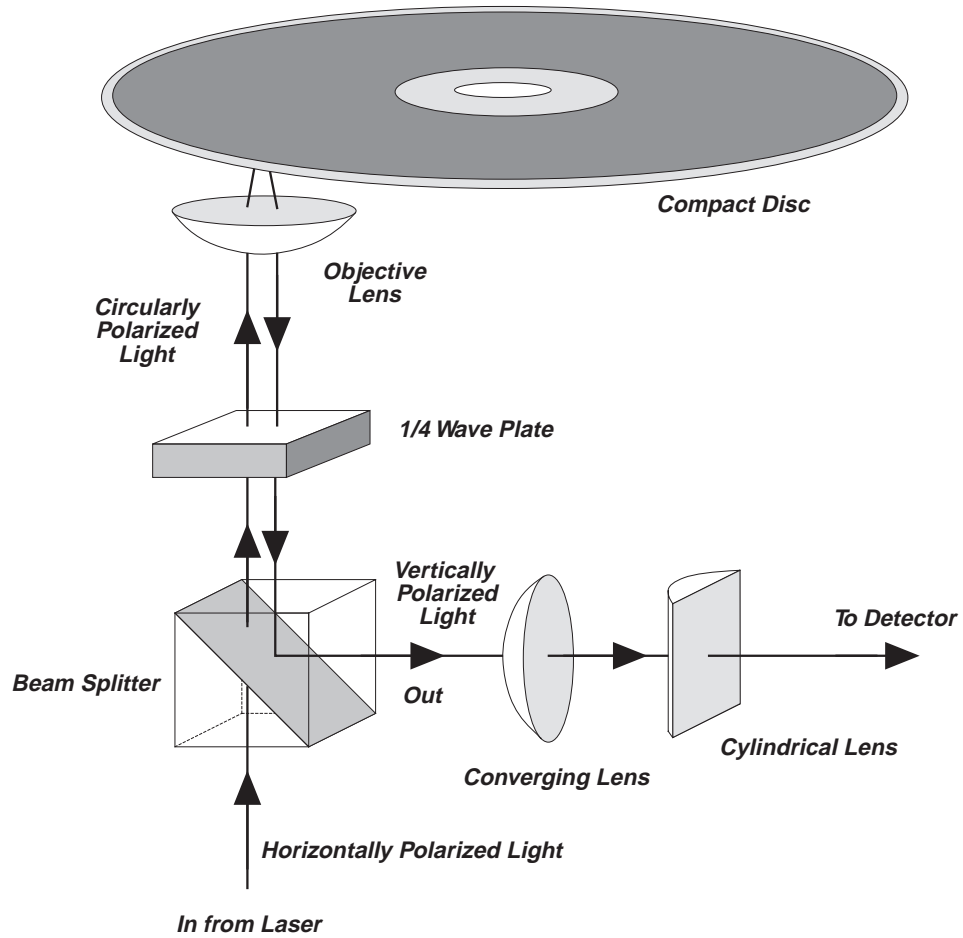
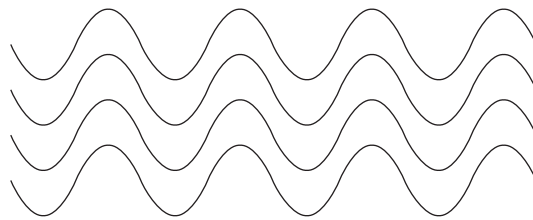
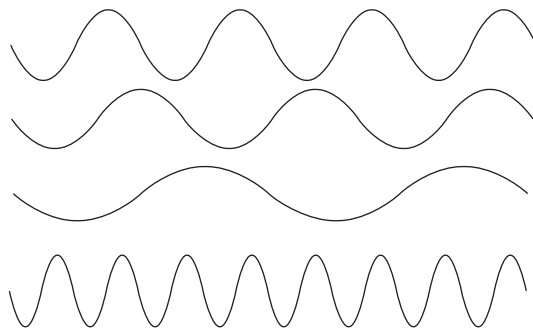

Figure 10.22: Path of laser beam and role of its polarization.



Coherent Beam of Light



Incoherent Beam of Light

Figure 10.23: Coherent and incoherent beams of light.

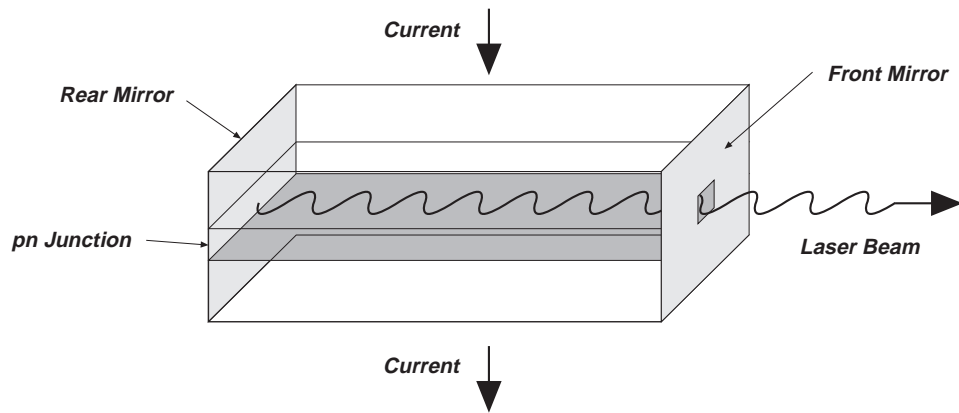

Figure 10.24: Semiconductor laser.

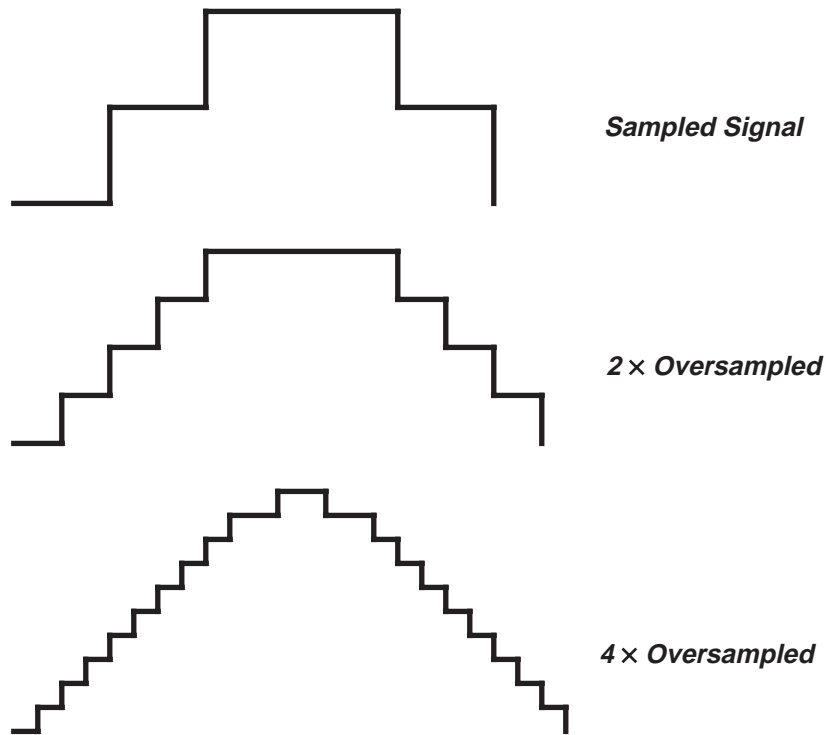

Figure 10.25: Effect of 2-times and 4-times oversampling.

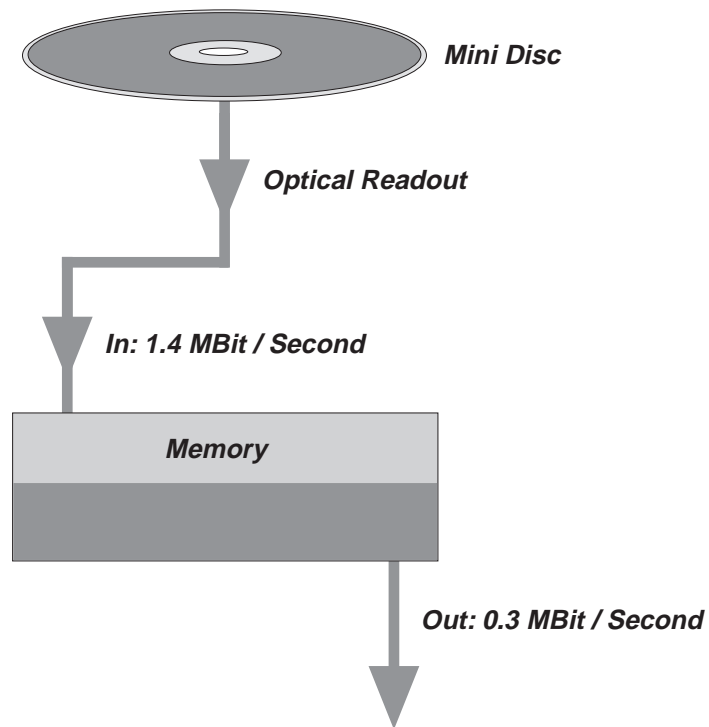

Figure 10.26: Shock-proof memory in mini-disc.

Chapter 11

Digital Magnetic Recording & Playback

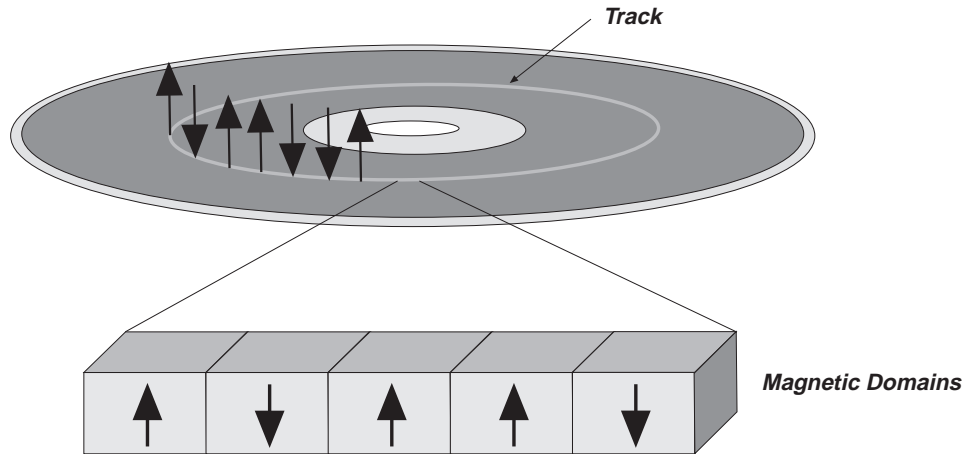

Figure 11.1: Magnetic digital signals recorded vertically on a mini disc.

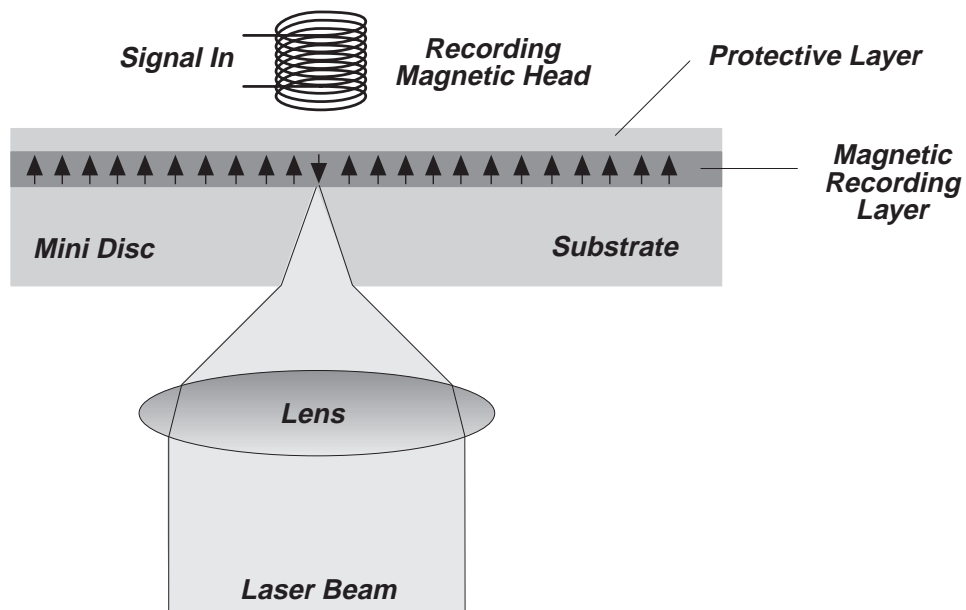

Figure 11.2: Recording digital signals on a mini disc.

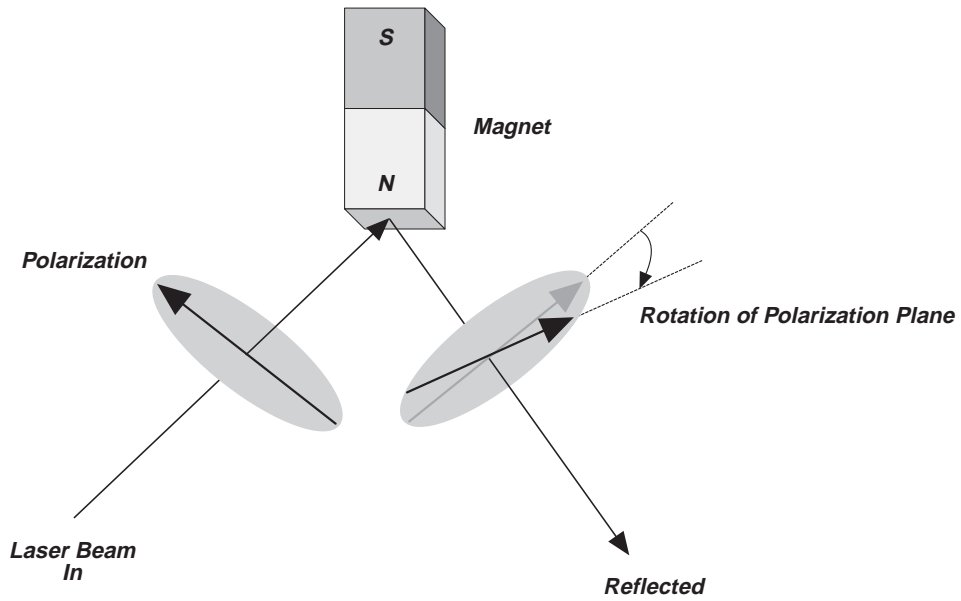

Figure 11.3: Kerr effect: plane of polarization of light beam rotates upon reflection from a magnetized surface.

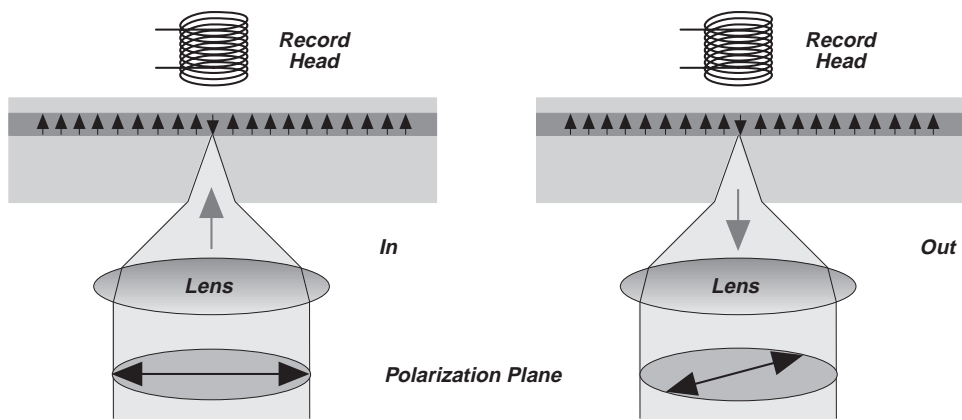

Figure 11.4: Read-out of digital information using Kerr effect. Magnetic field direction affects plane of polarization of reflected laser beam.

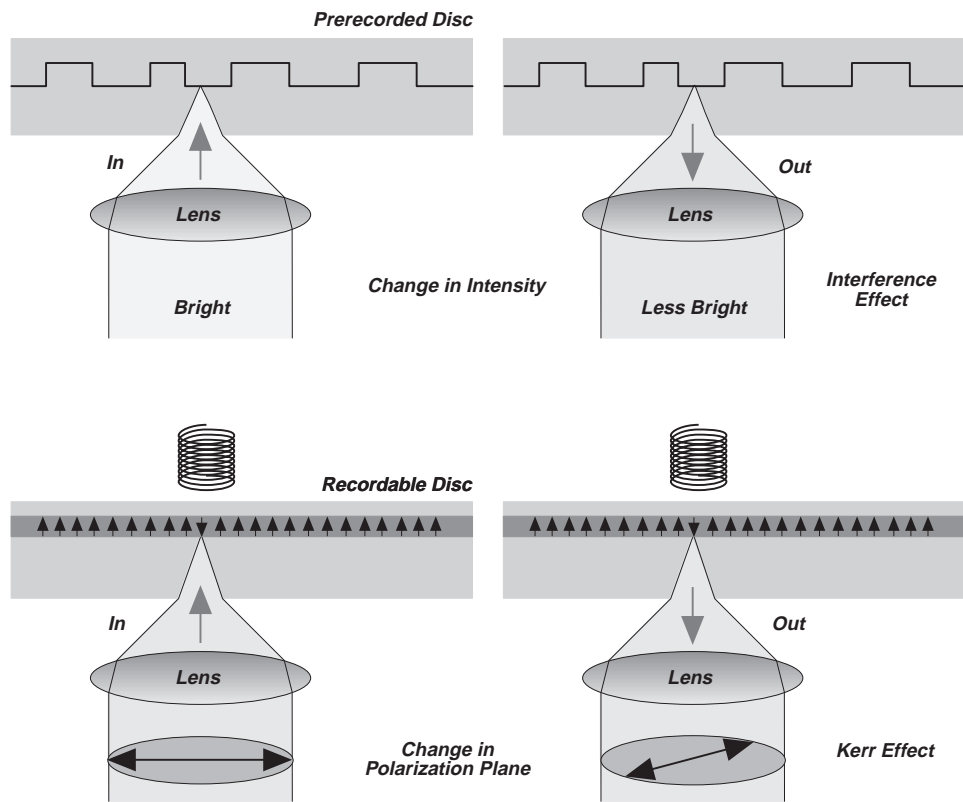

Figure 11.5: Difference in read-out between pre-recorded and recordable mini-discs.

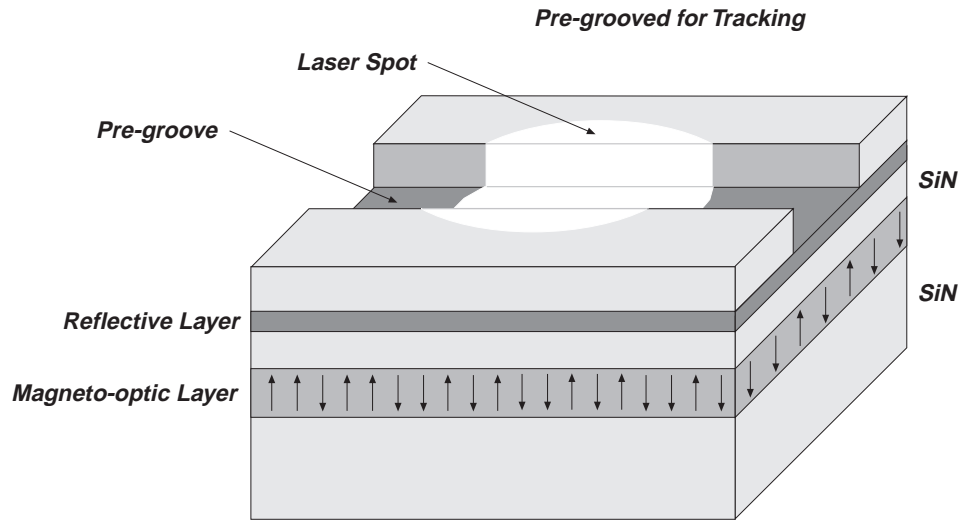

Figure 11.6: Section of a recordable mini disc.

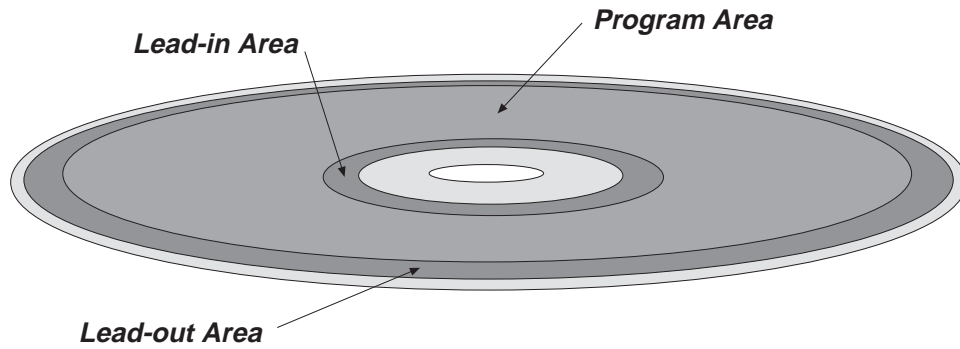

Figure 11.7: Layered structure of recordable mini disc.



Figure 11.8: Track pattern in DCC tape.

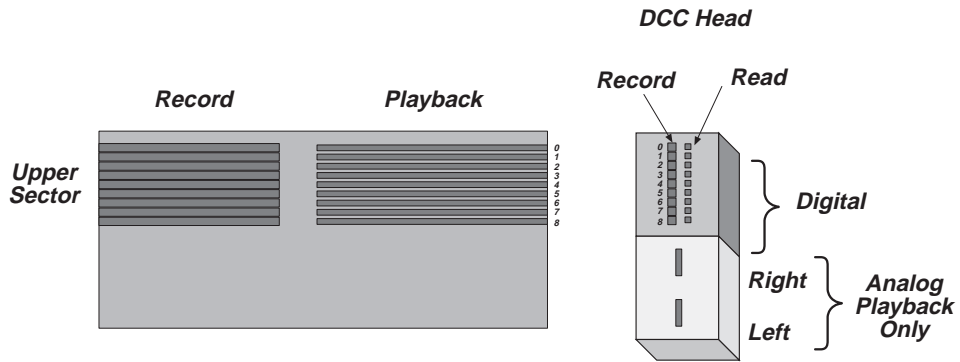

Figure 11.9: The playback head reads only a portion of the recorded track.

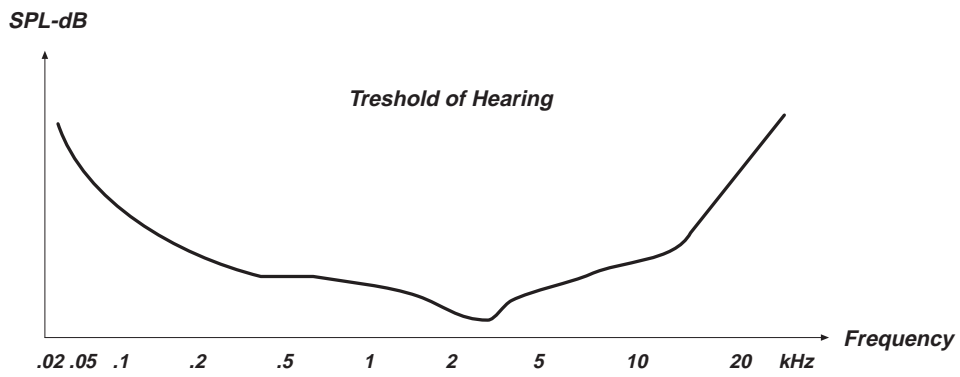

Figure 11.10: Threshold of hearing curve.

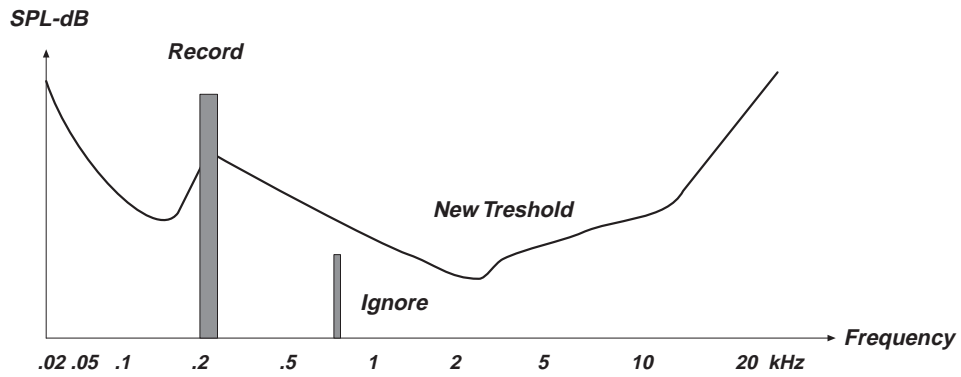

Figure 11.11: Sounds which will be recorded by PASC and masking of quiet passages.

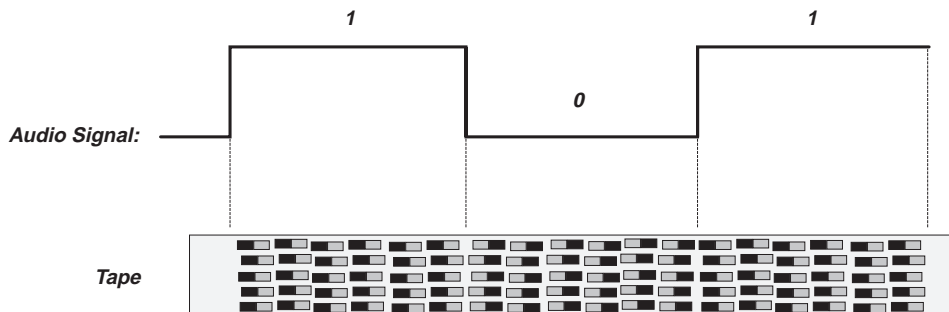

Figure 11.12: Representation of digital signal on magnetic tape.

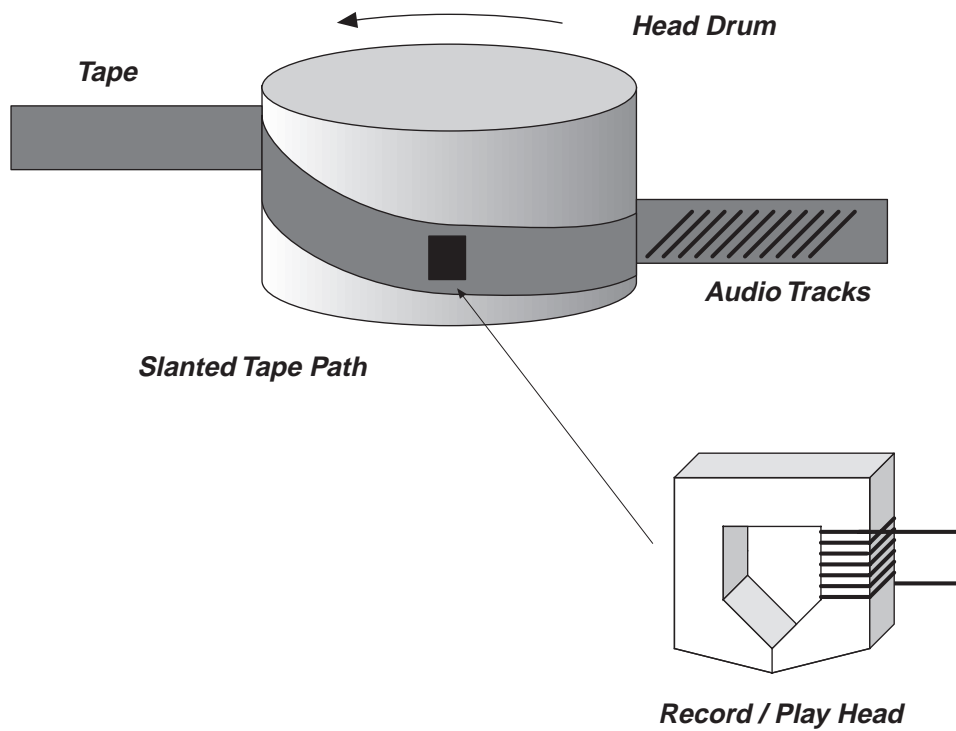

Figure 11.13: Helical recording with rotating heads.

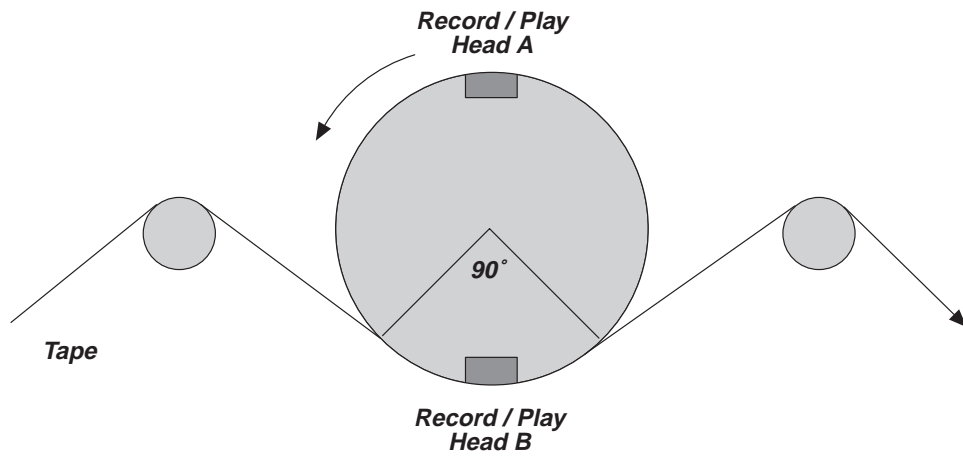

Figure 11.14: Tape contact to rotating head.

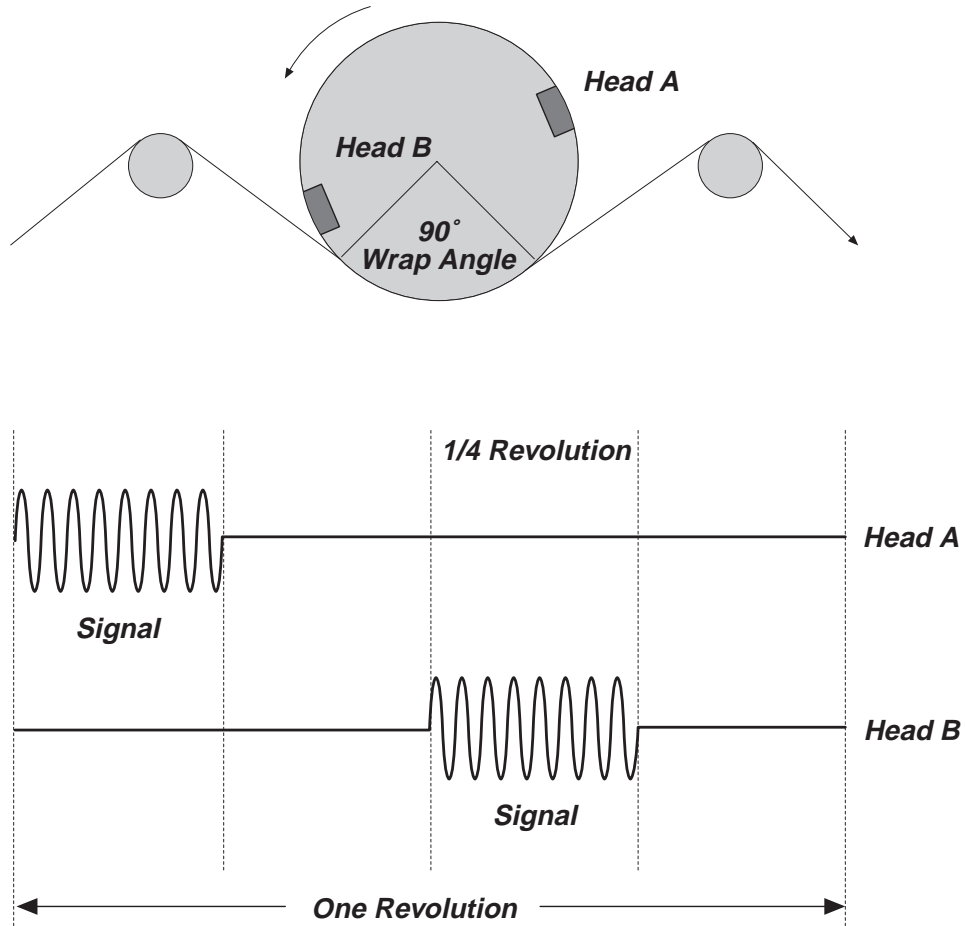

Figure 11.15: Time compression to reduce wrap angle.

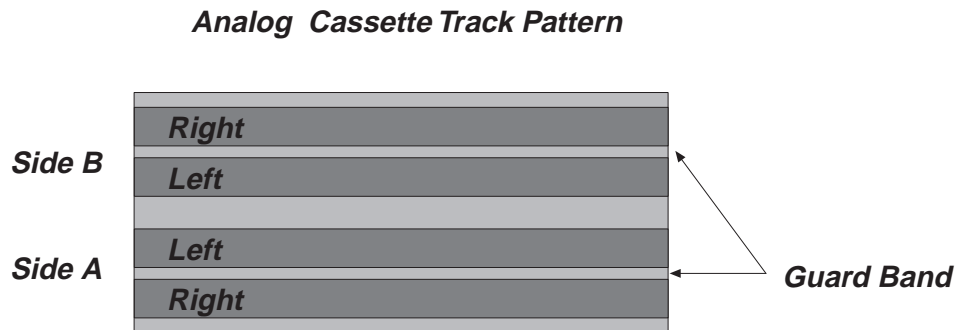

Figure 11.16: Guard band between tracks on analog tape reduces cross-talk.

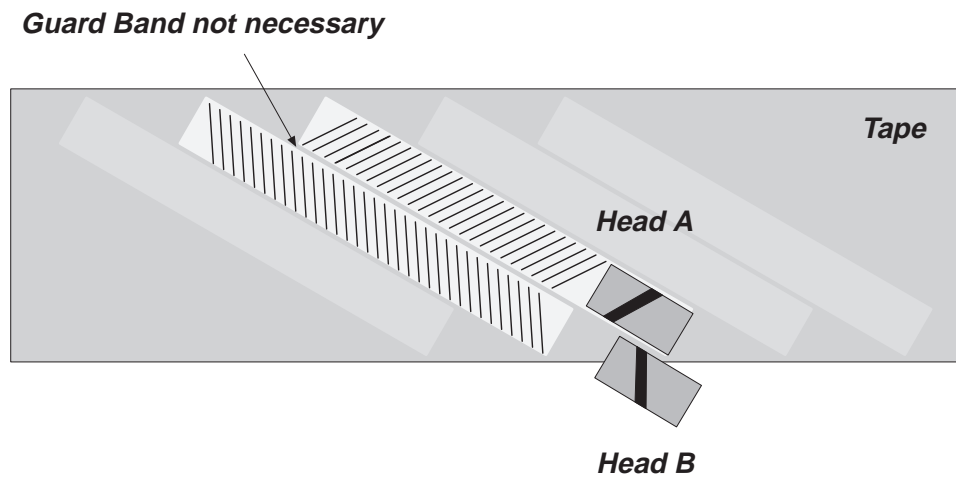

Figure 11.17: Azimuthal recording.

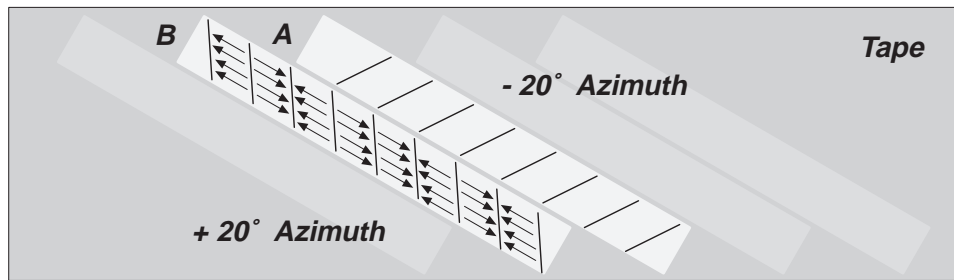

Figure 11.18: Digital information on magnetic tape recorded longitudinally.

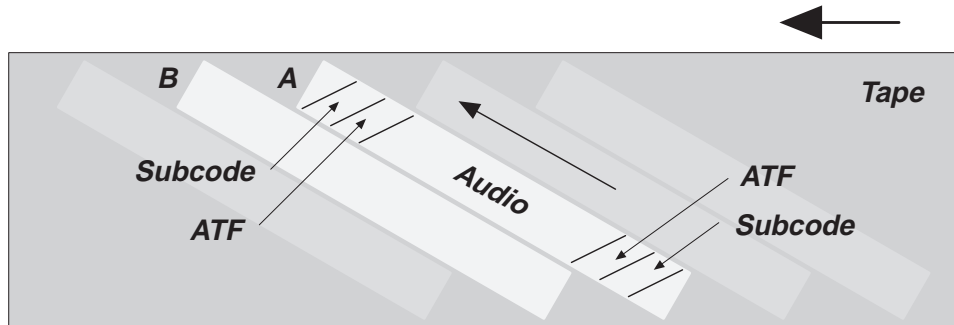

Figure 11.19: Arrangement of signals on a tape.

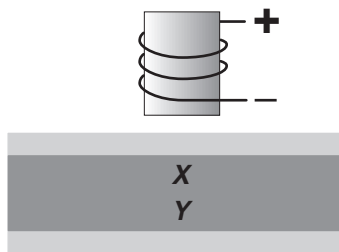

Figure 11.20: Exercise 11.7.

Chapter 12

Heat

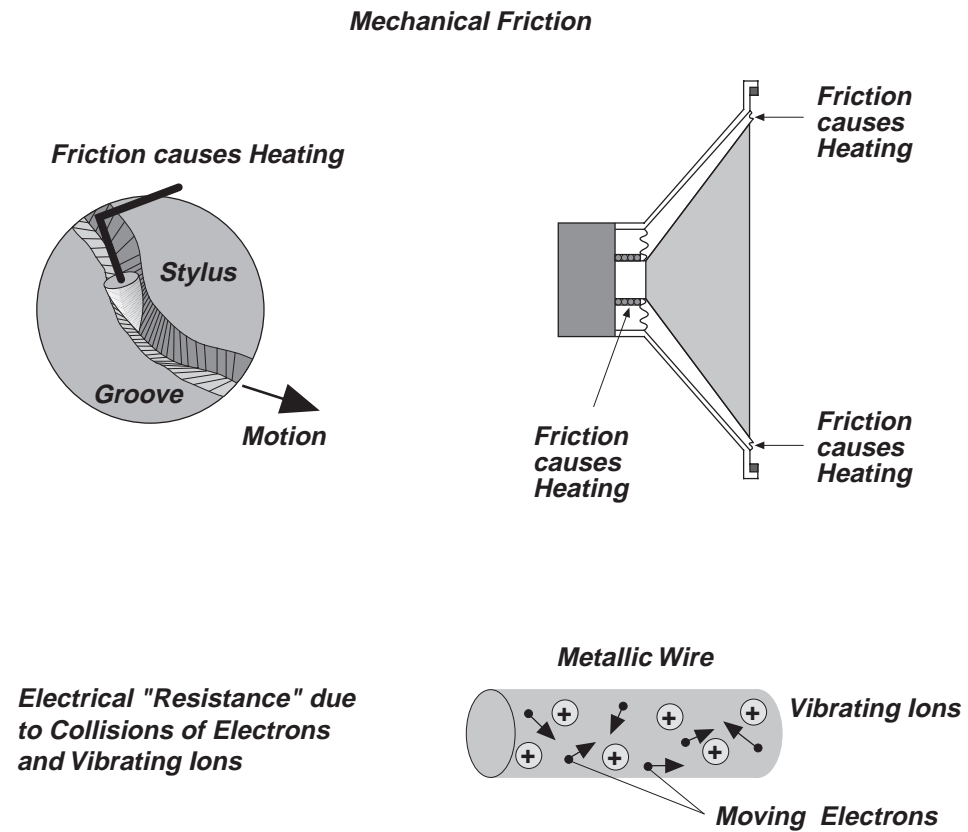

Figure 12.1: Sources of heating in hi-fi due to mechanical friction and electrical "friction".

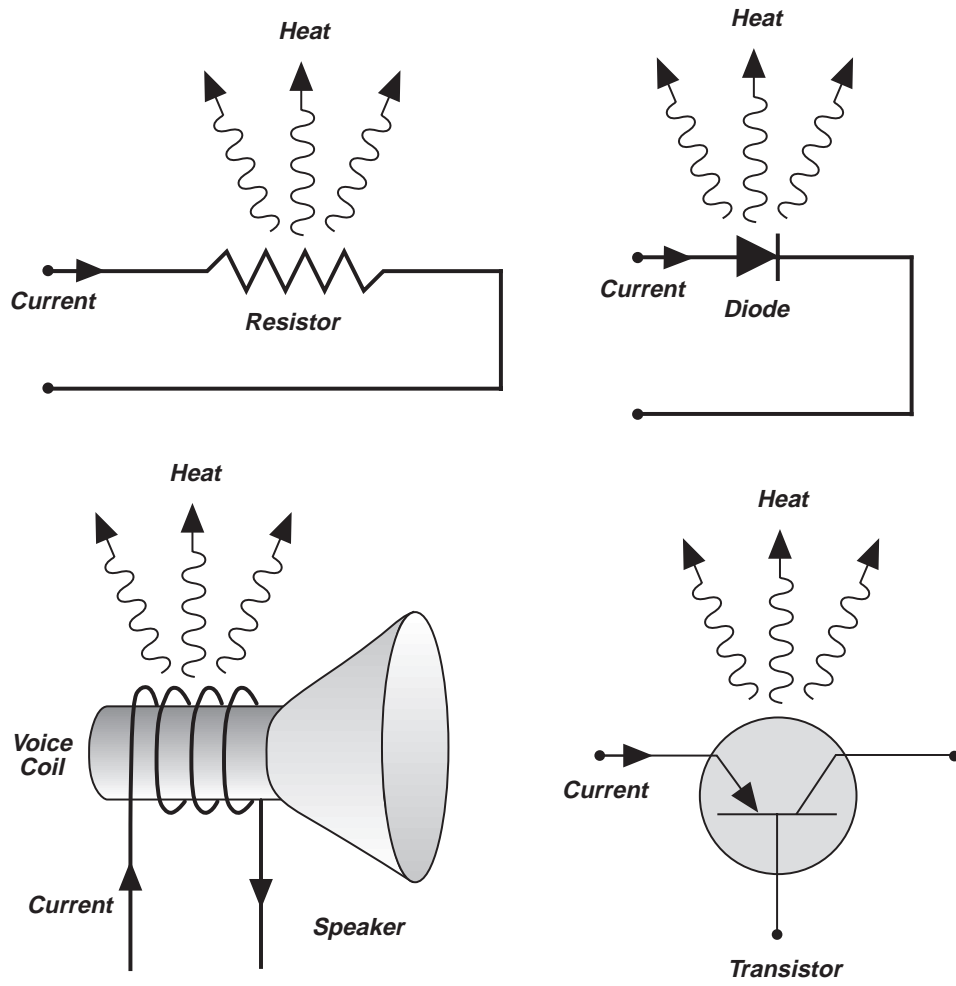

Figure 12.2: Electrical “friction” causes heating in amplifier components and voice coil.

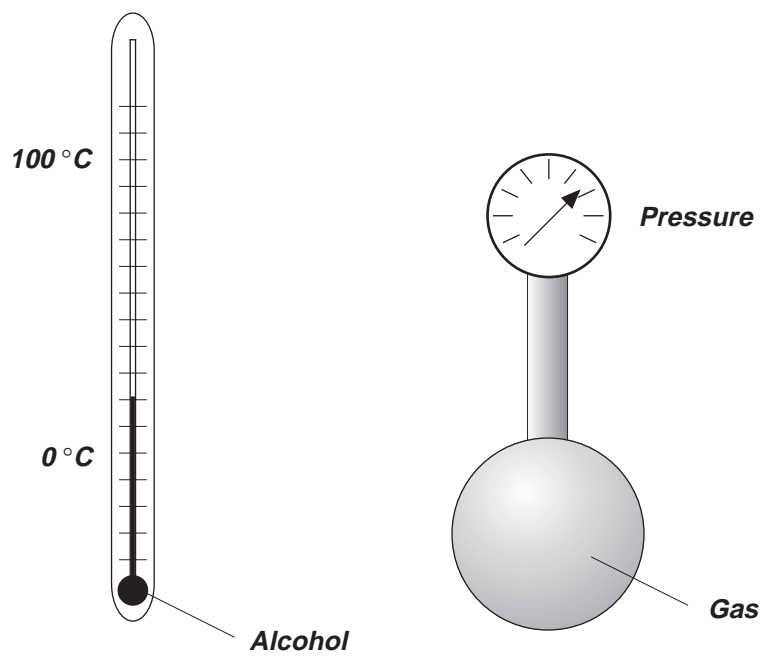

Figure 12.3: Two types of thermometers: alcohol expansion thermometer and gas thermometer.

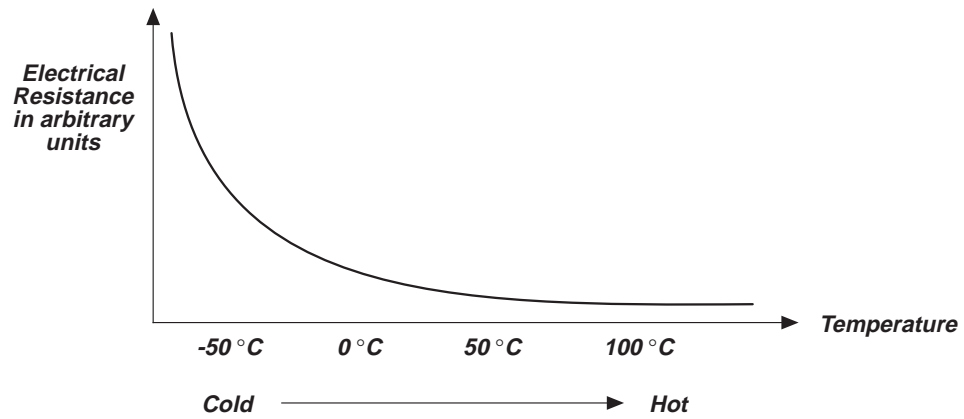

Figure 12.4: Temperature dependence of electric resistance of a semiconductor.

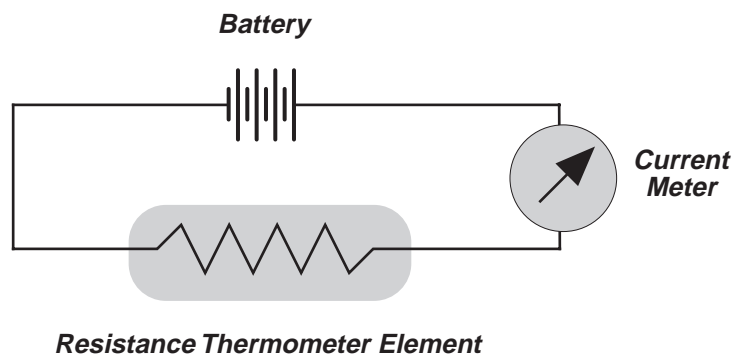

Figure 12.5: Basic circuit for resistance thermometer.

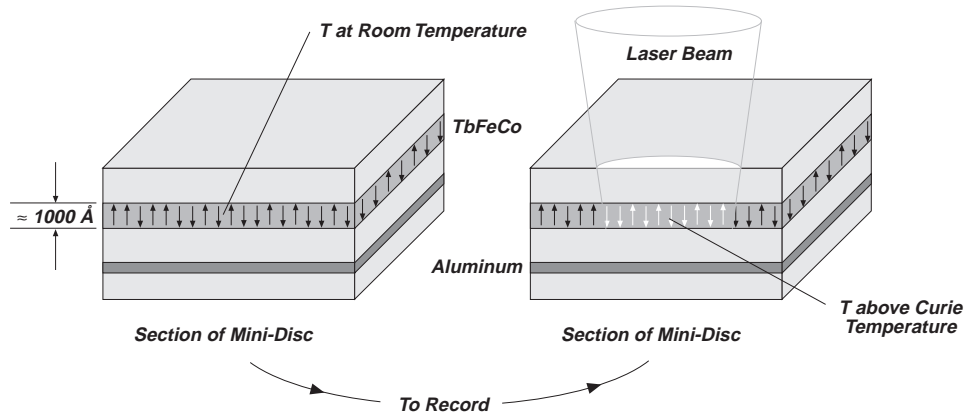

Figure 12.6: Heating of spot on mini-disc for recording.

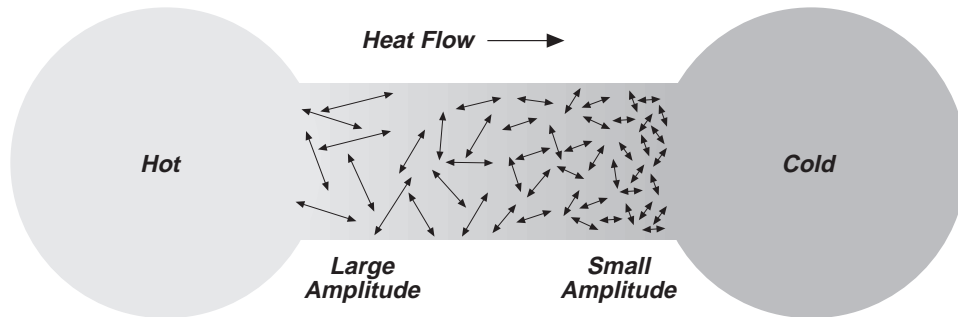

Figure 12.7: Heat conduction along a bar between a hot body and a cold one.

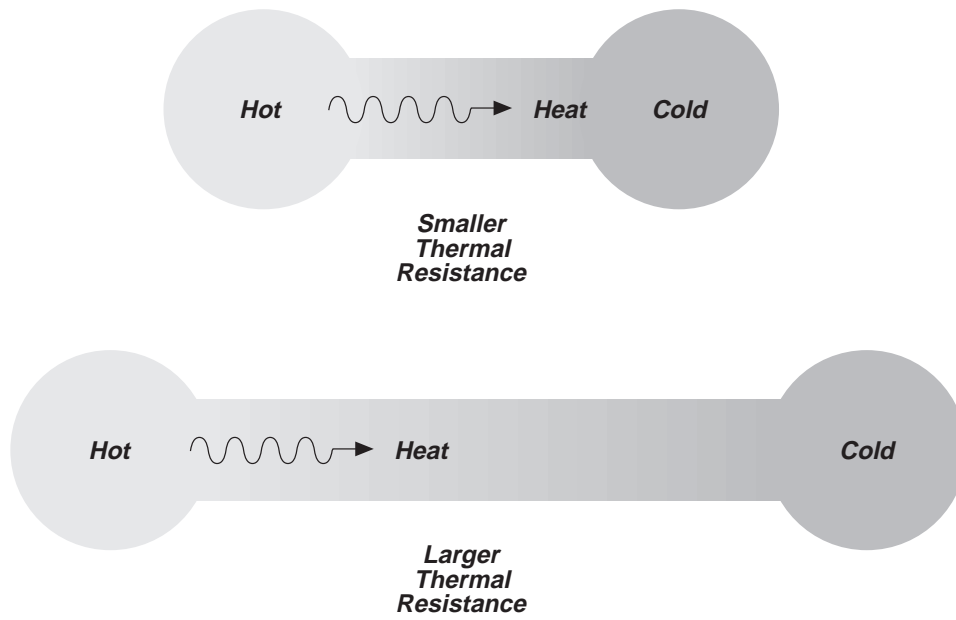

Figure 12.8: Thermal resistance depends on length of heat conductor.

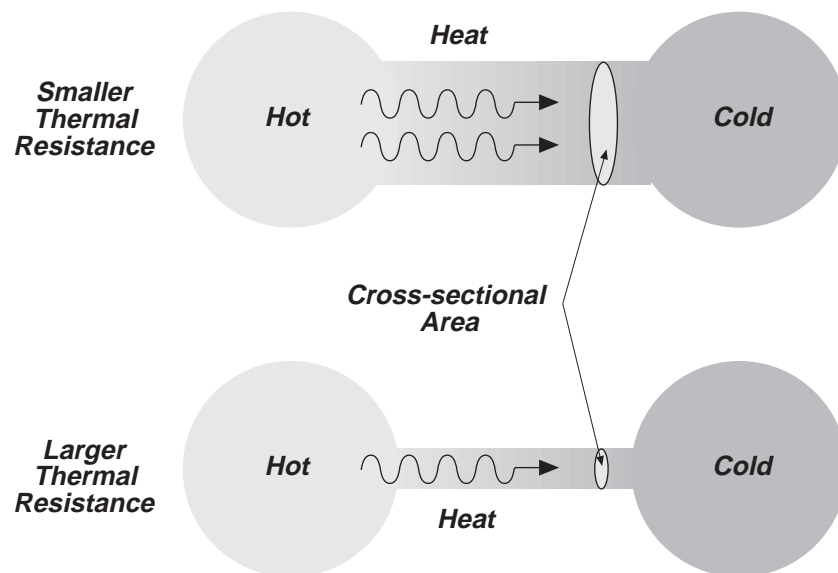

Figure 12.9: Thermal resistance depends inversely on cross-sectional area of heat conductor.

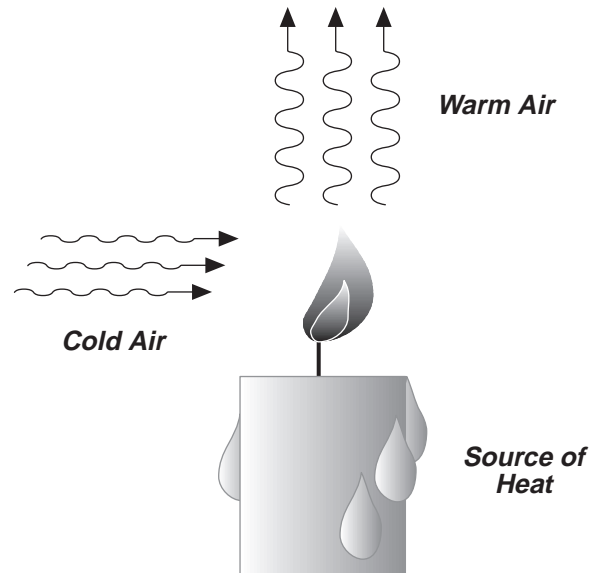

Figure 12.10: Transfer of heat in air by convection.

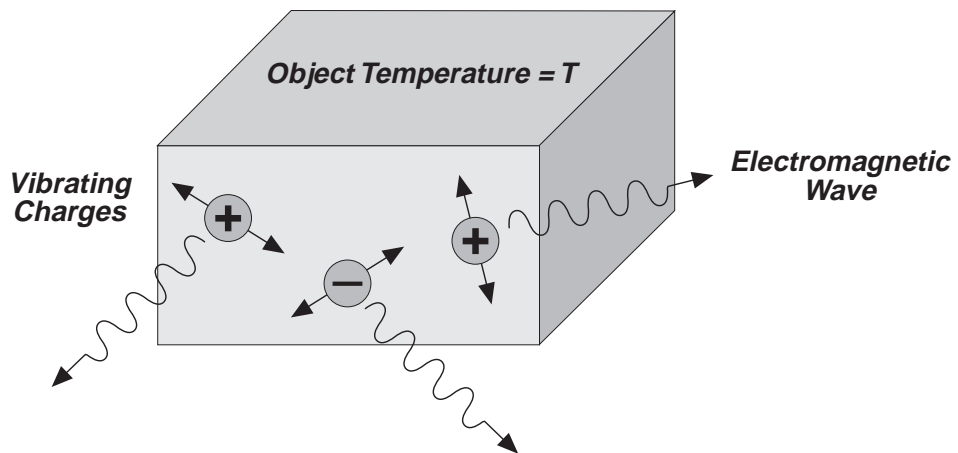

Figure 12.11: Object at temperature T emits electromagnetic waves.

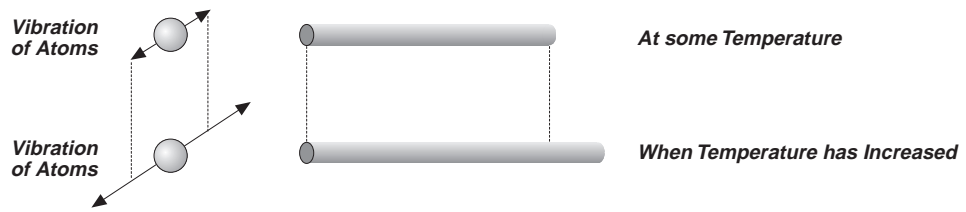

Figure 12.12: Thermal expansion of an object when heated.

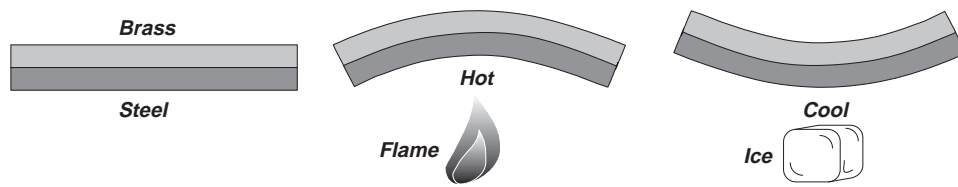

Figure 12.13: Bimetallic strip and its behavior when heated or cooled.

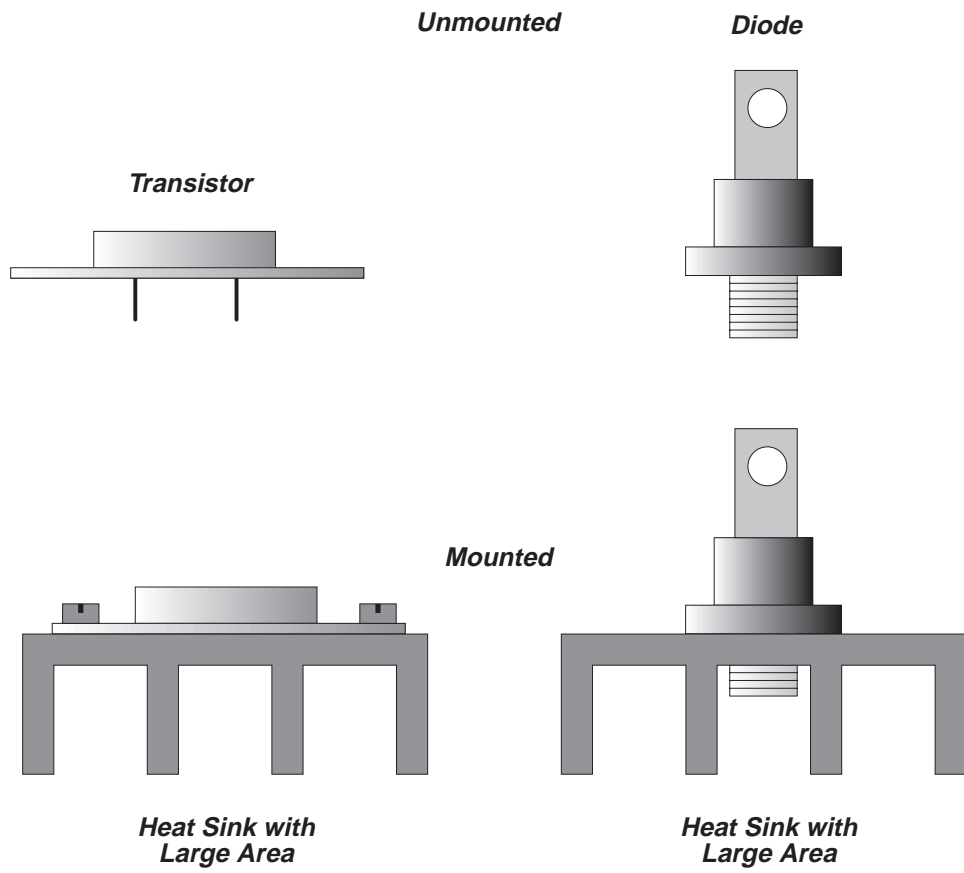

Figure 12.14: Mounting of transistor and diode on heat sink to transfer heat away from devices by heat conduction.

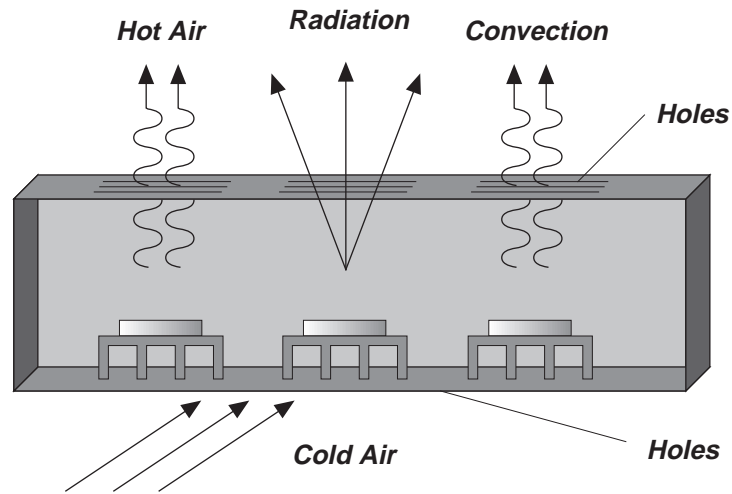

Figure 12.15: Heat removal by convection and radiation.

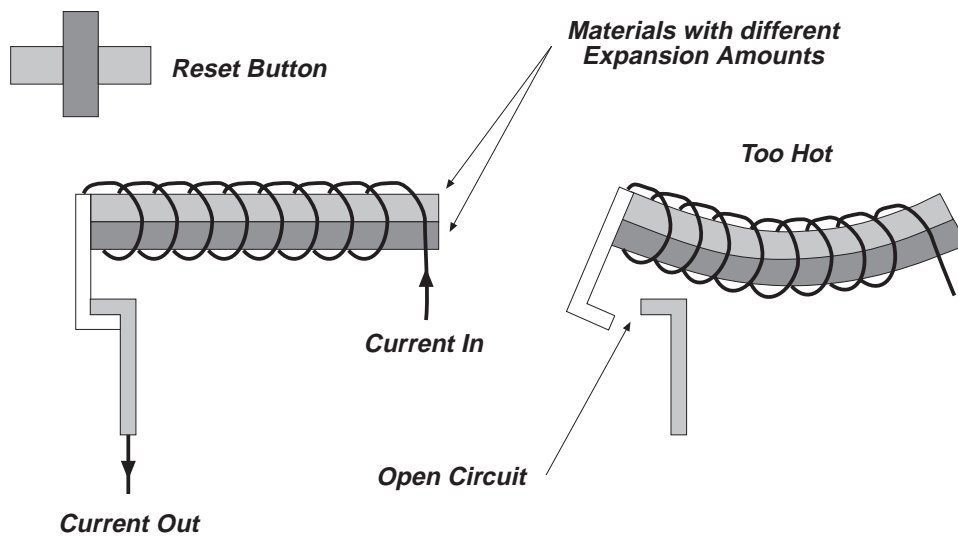

Figure 12.16: Action of circuit-breaker when too hot.

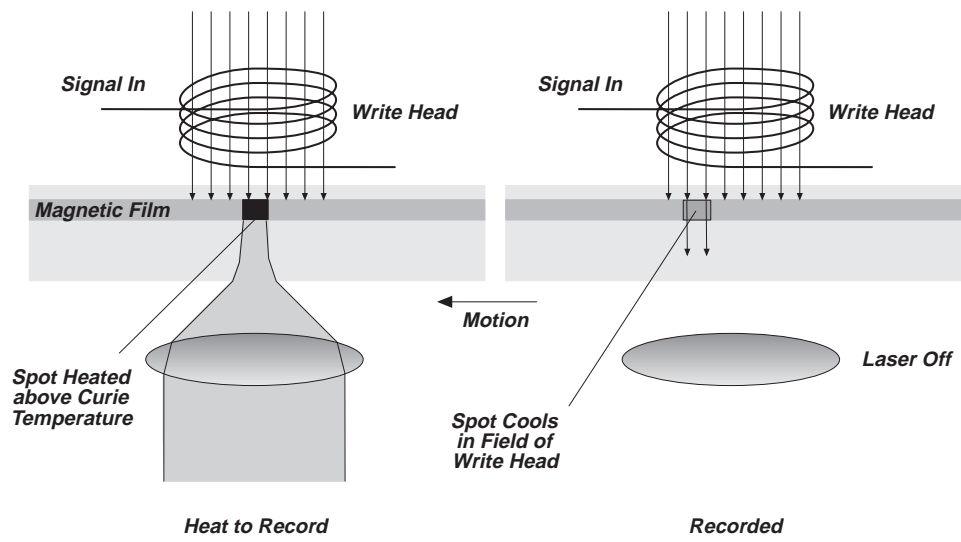

Figure 12.17: Thermo-magnetic recording on mini-Disc.

Chapter 13

Mechanics

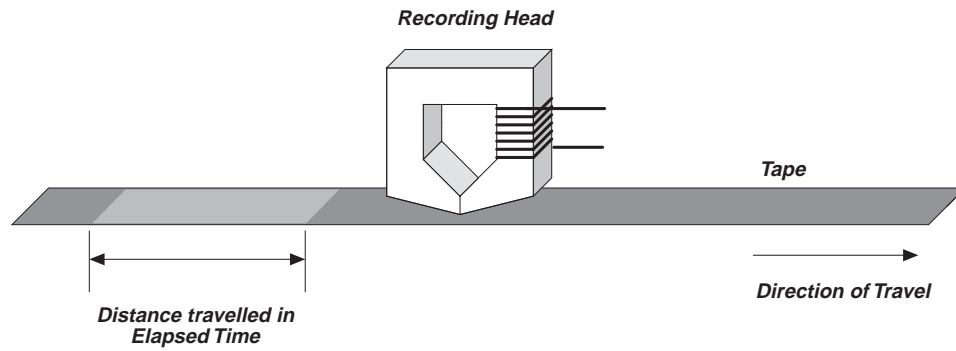

Figure 13.1: Speed of tape past recording head.

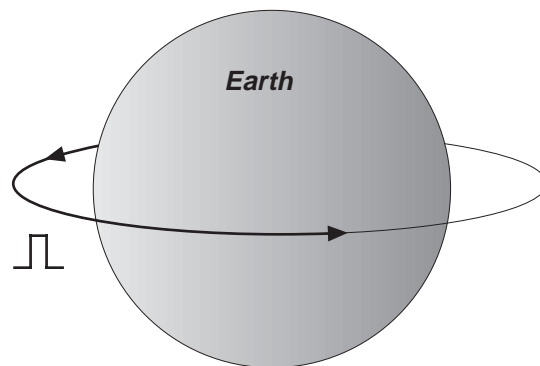

Figure 13.2: Time for a radio wave to go around the Earth at the equator.

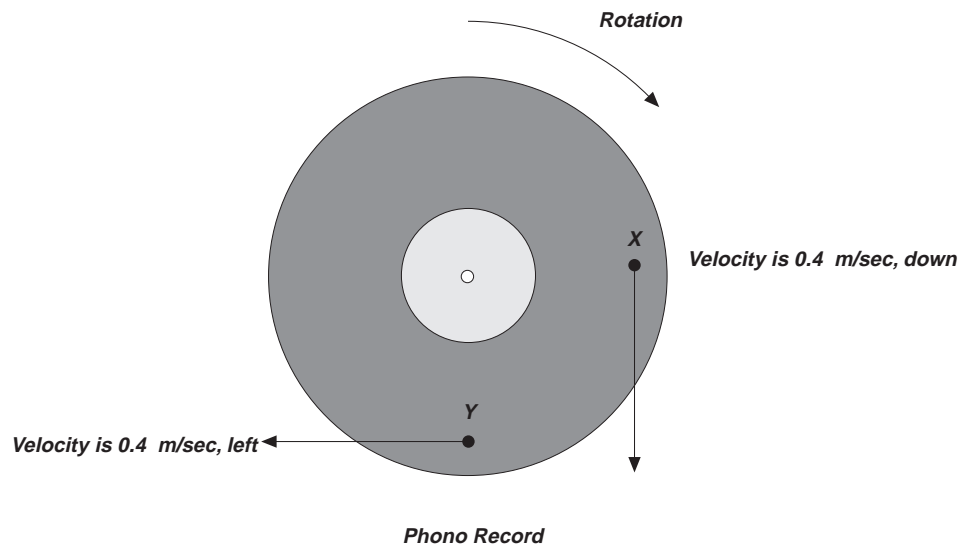

Figure 13.3: Speed of a recorded signal is the same at **X** and at **Y**; their velocities are different.

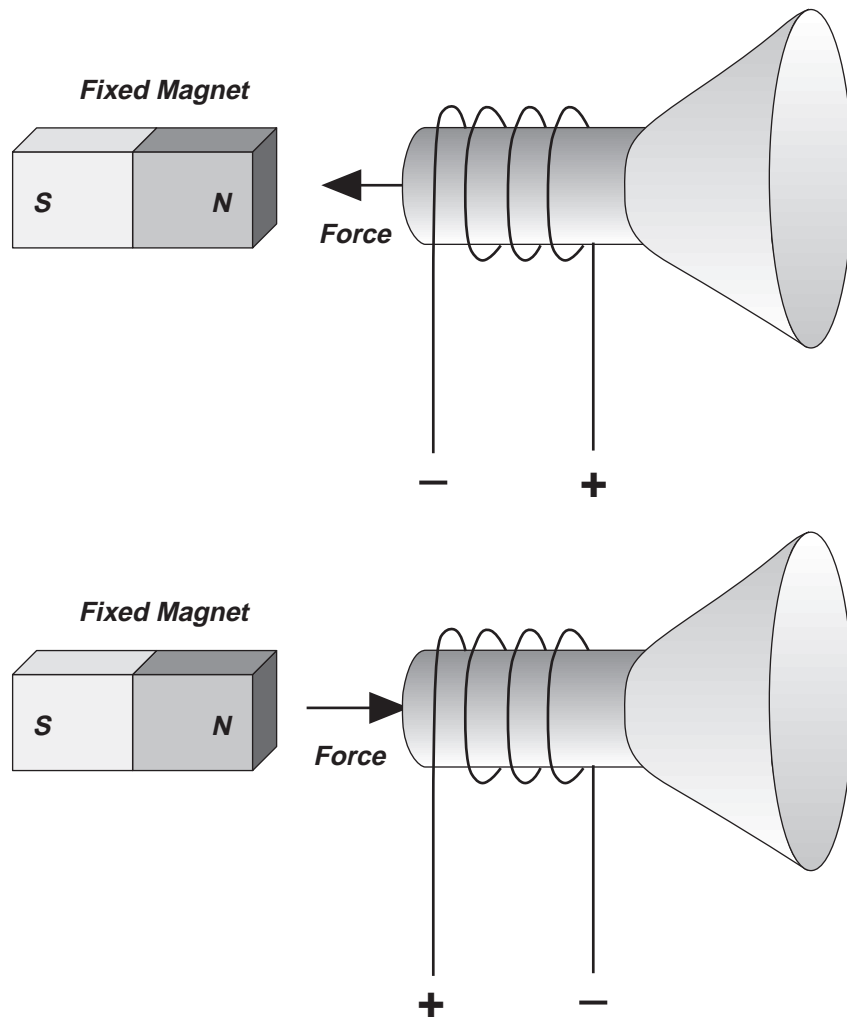

Figure 13.4: Force on voice coil giving it a push or a pull depending on direction of current in voice coil.

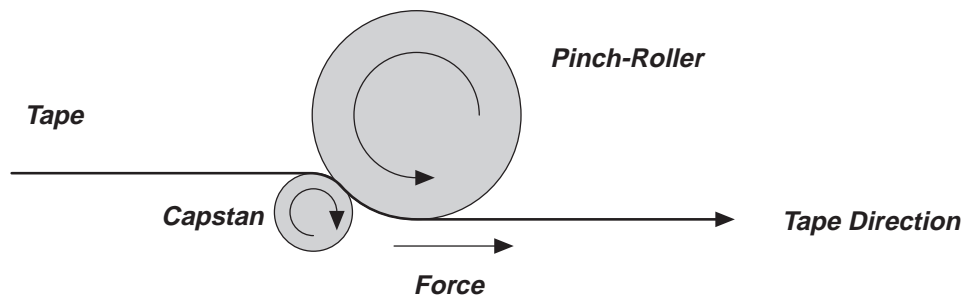

Figure 13.5: Force on tape by capstan-pinch roller.

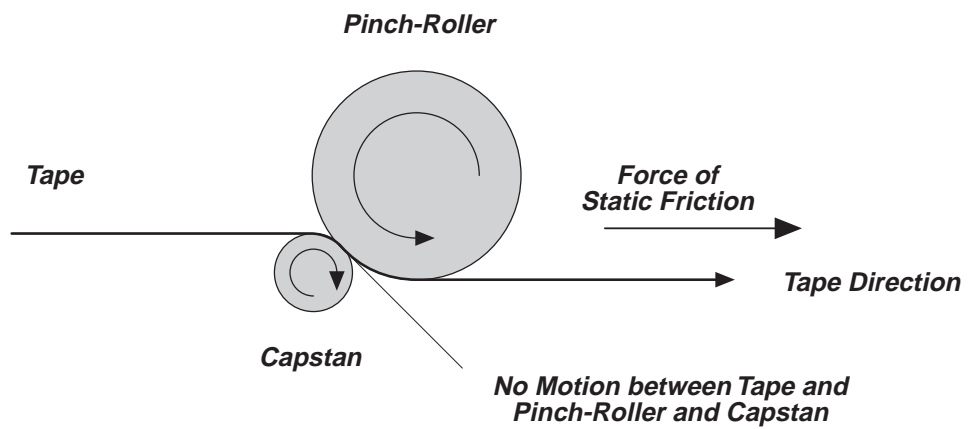

Figure 13.6: Static friction-force pulling on tape.

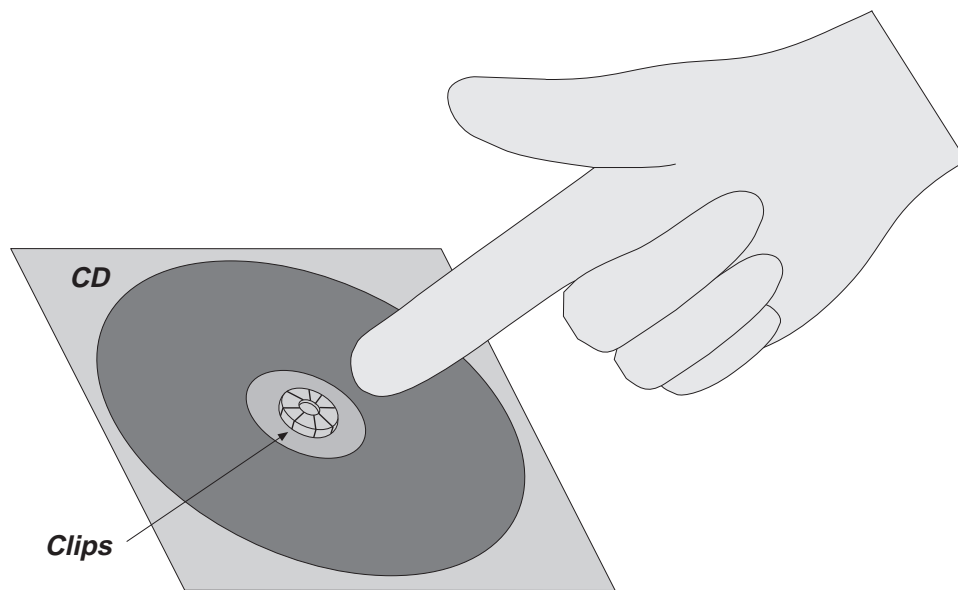
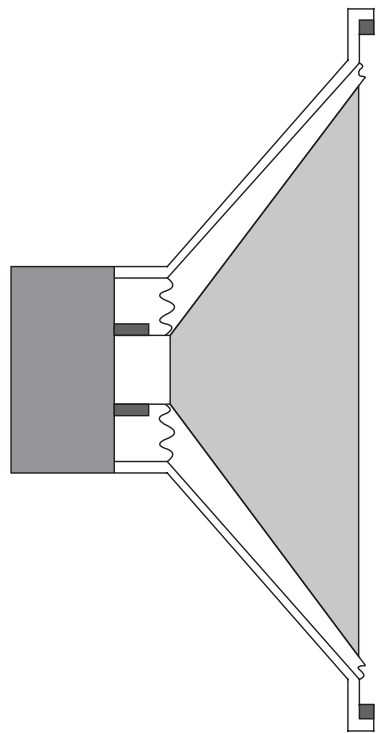
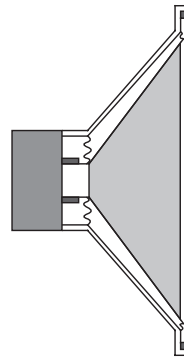

Figure 13.7: Releasing a CD from its case by applying a pressure on the clips with a finger.



Woofer has Large Inertia



Tweeter has Small Inertia

Figure 13.8: Inertia of a tweeter is less than that of a woofer.

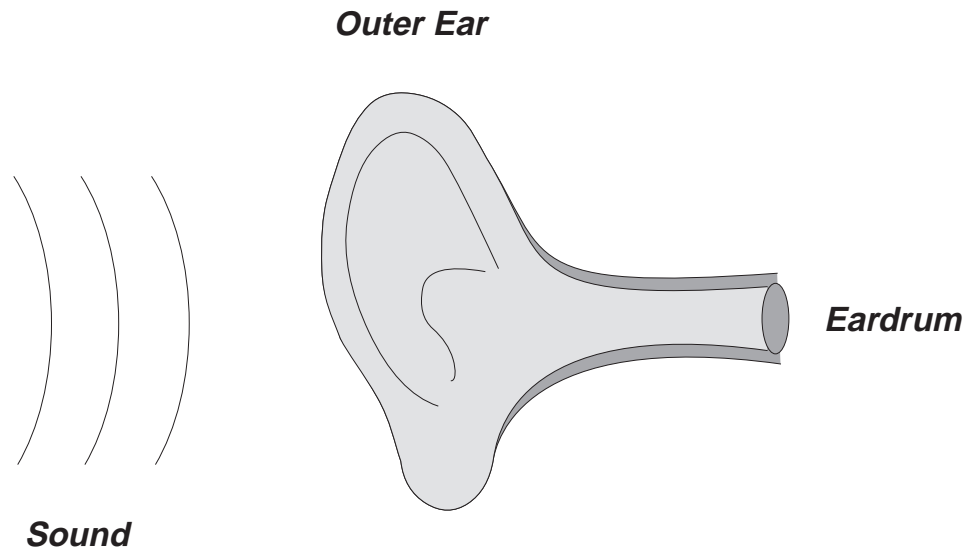

Figure 13.9: Outer ear; ear drum's inertia limits response at frequencies above 20 kHz.

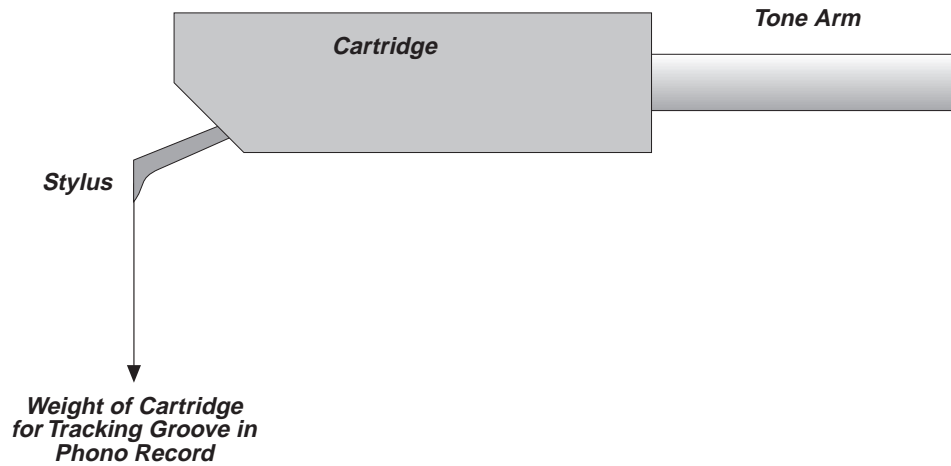

Figure 13.10: Adjusted weight in cartridge for helping the stylus to track the groove in phono record.

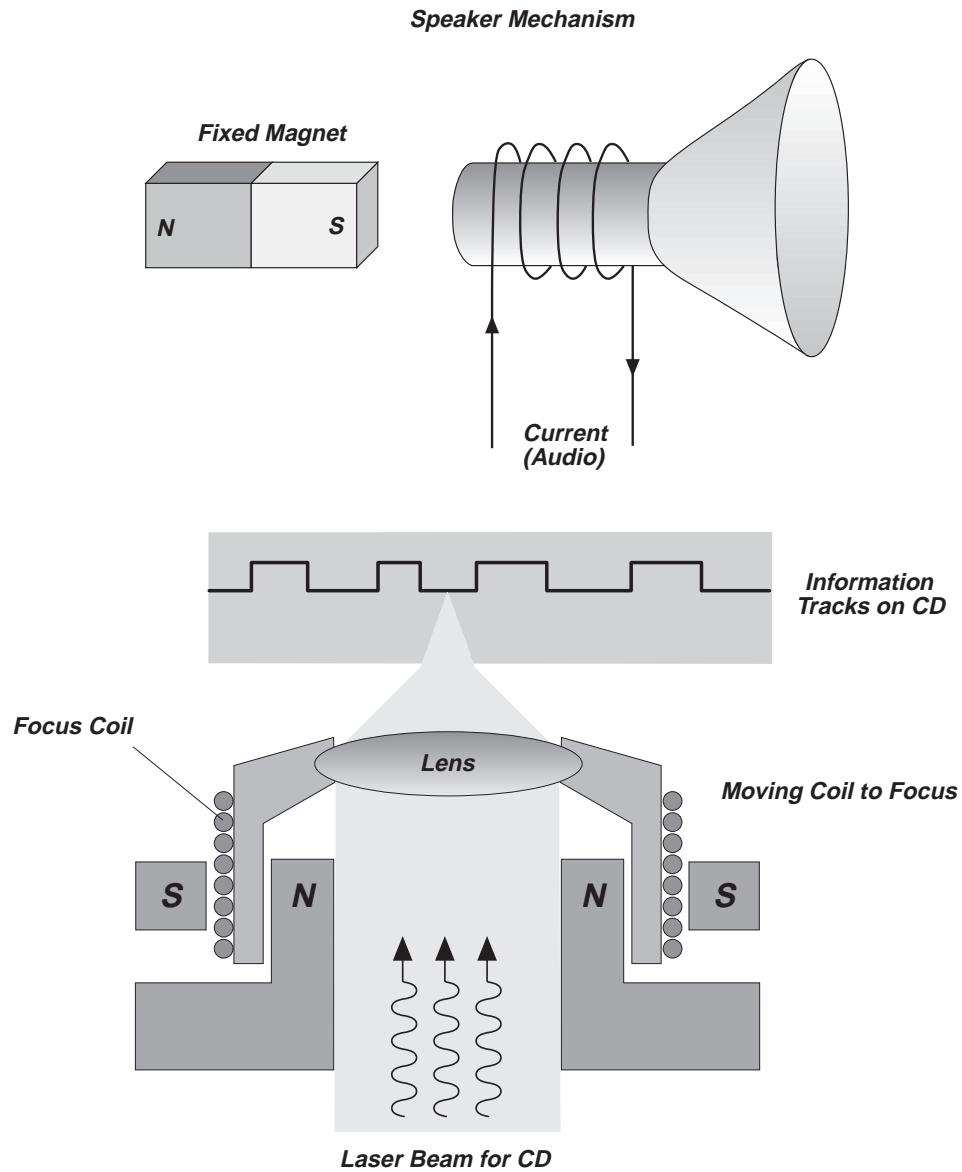

Figure 13.11: Force of clamped magnet on a voice coil accelerates diaphragm in loudspeaker. Force of clamped magnet on focus coil accelerates focus lens in CD player.

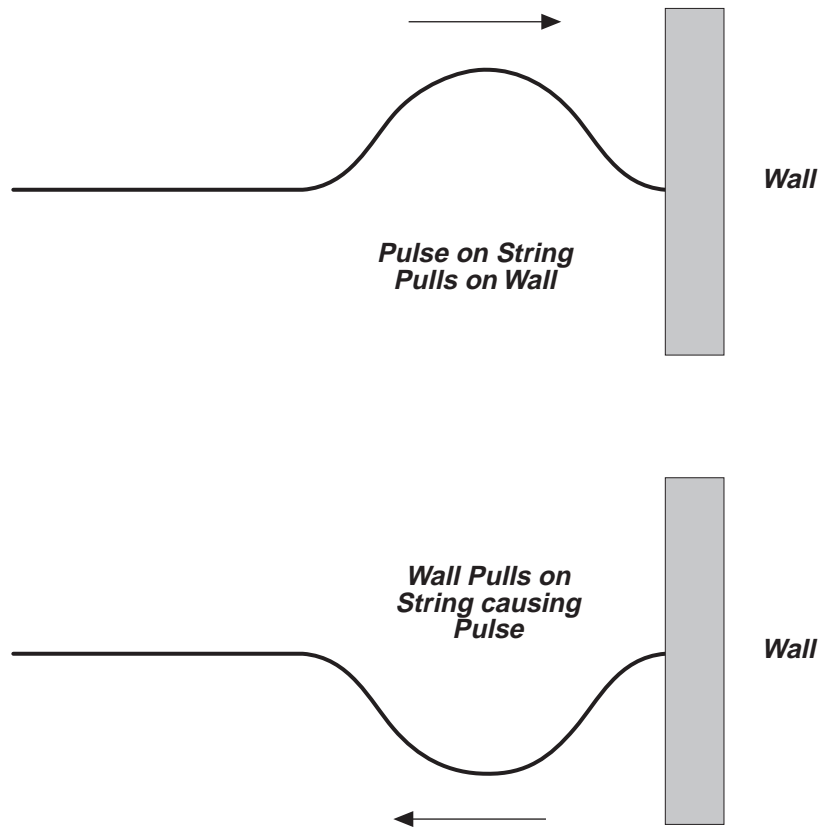

Figure 13.12: Reflection of a pulse on a string clamped at wall and its inversion.

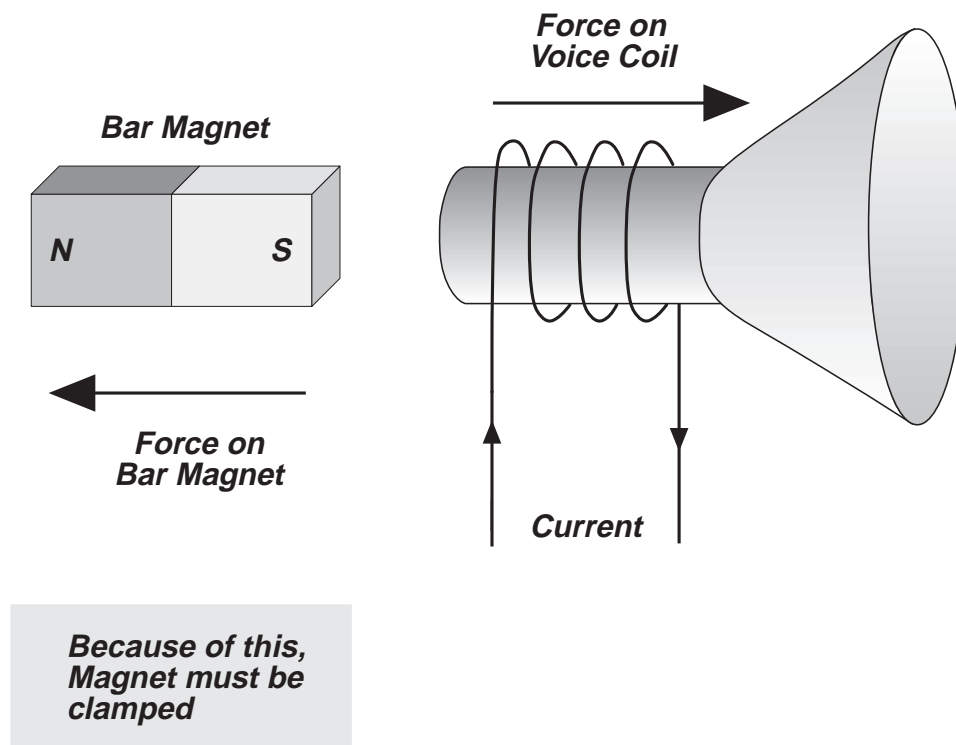

Figure 13.13: Force on voice coil and force on magnet.

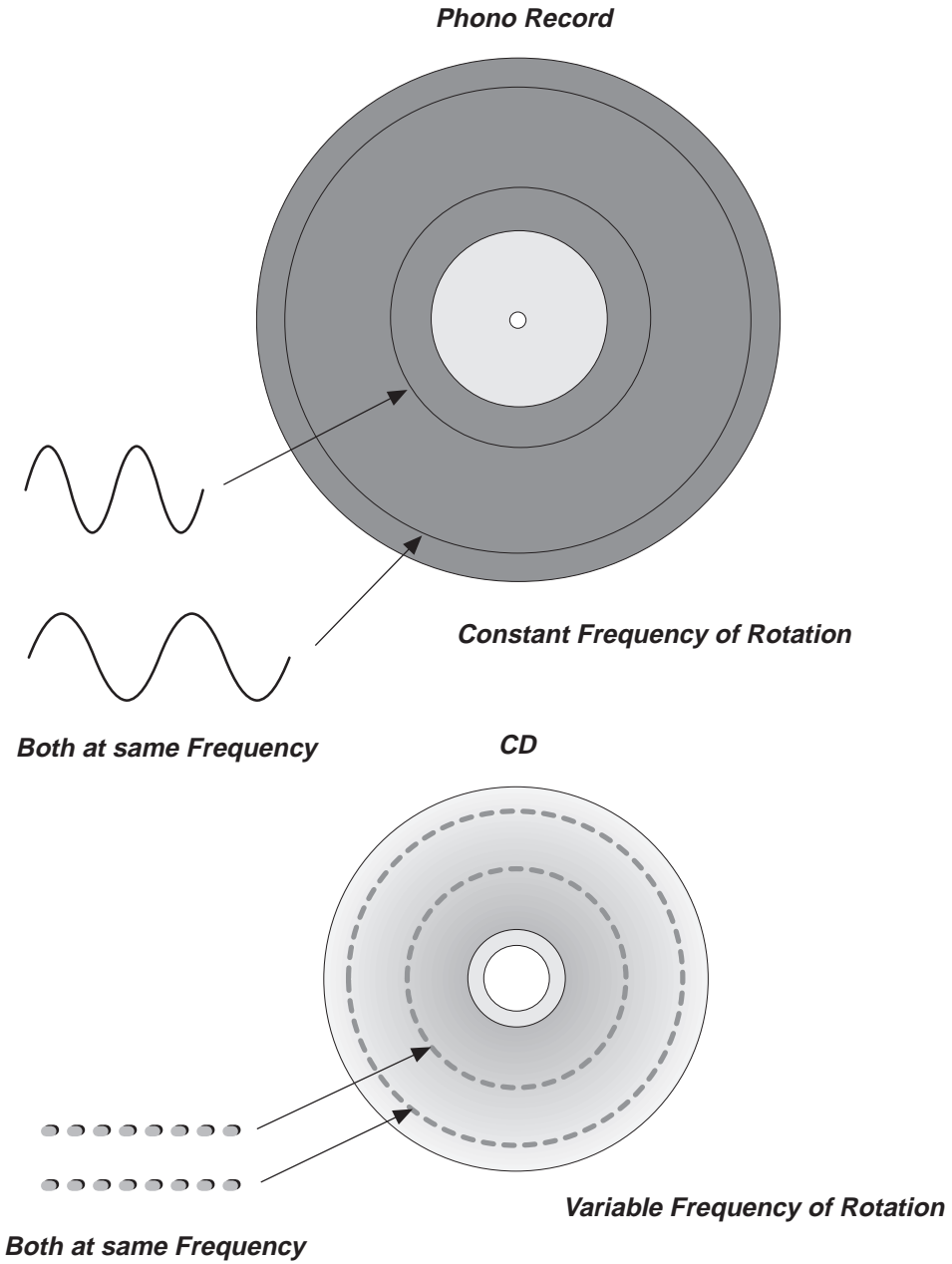

Figure 13.14: Waves recorded on a phono record and a CD.

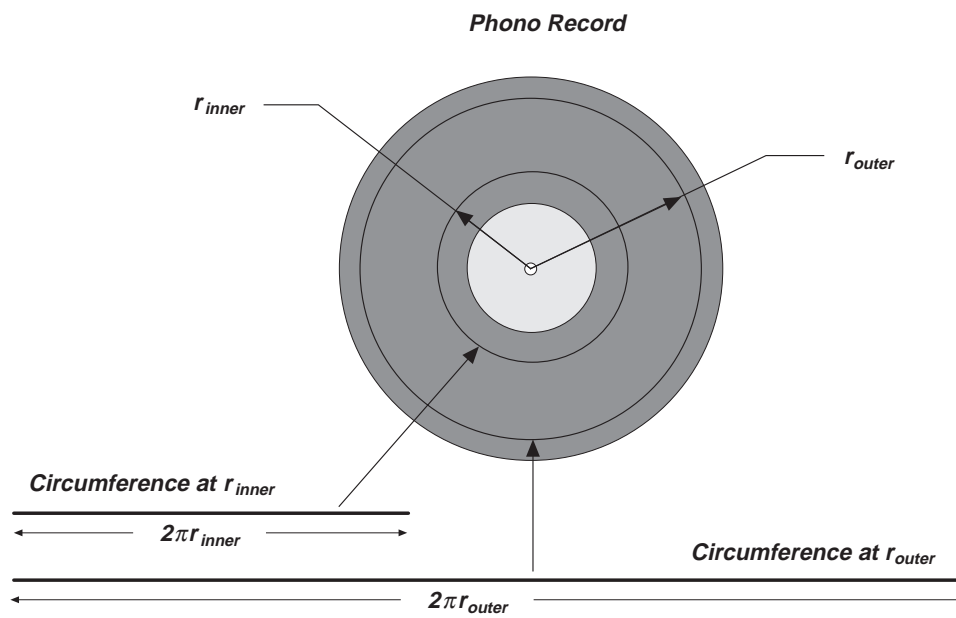

Figure 13.15: Distances covered along outer track and inner track on a phono record.

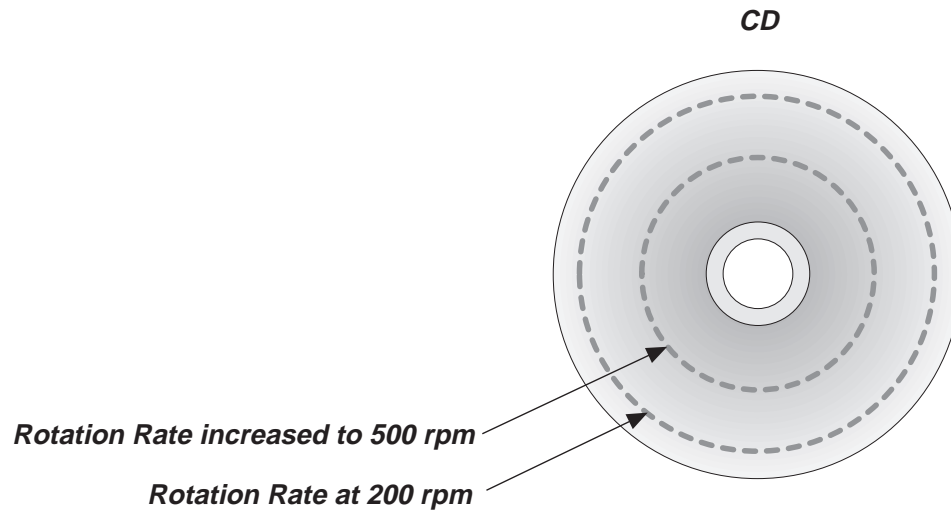

Figure 13.16: Frequency of rotation of a CD is made higher near the inner edge and lower near the outer edge to maintain constant linear speed on a tracks.

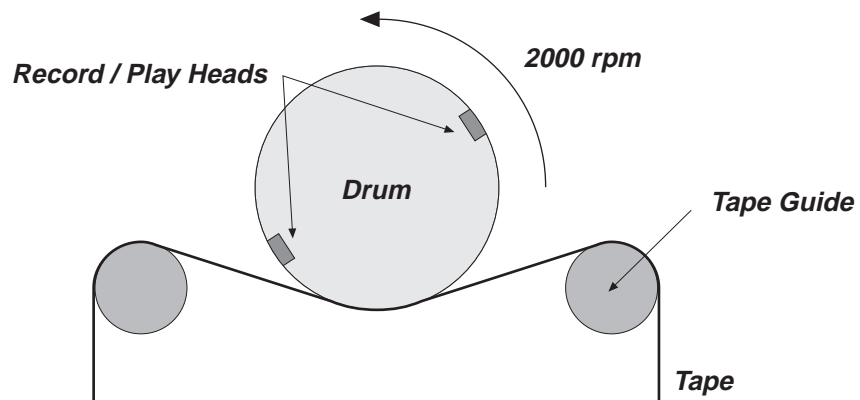
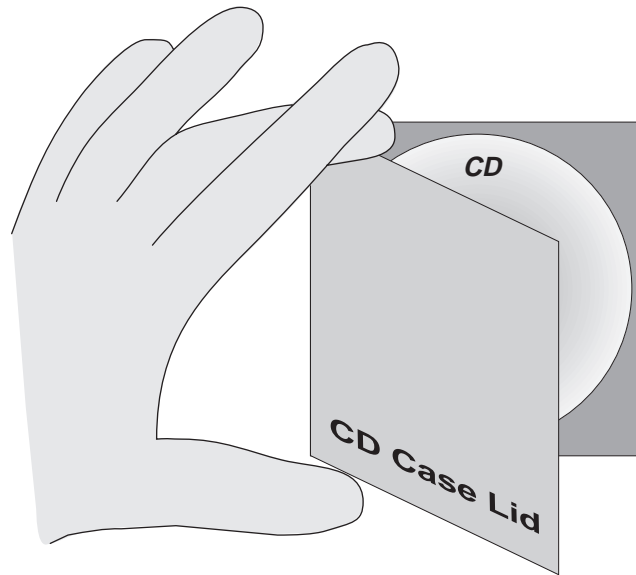
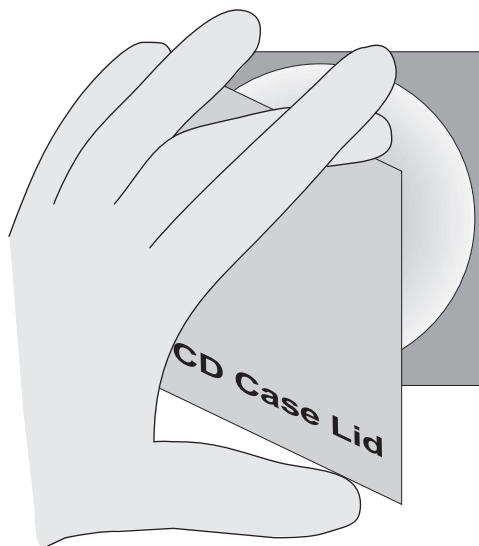

Figure 13.17: Rotation of drum head relative to magnetic tape in DAT.



A. Harder to Open



B. Easier to Open

Figure 13.18: When same force is applied to the CD case lid, it is easier to open the lid near the edge because torque is larger there.

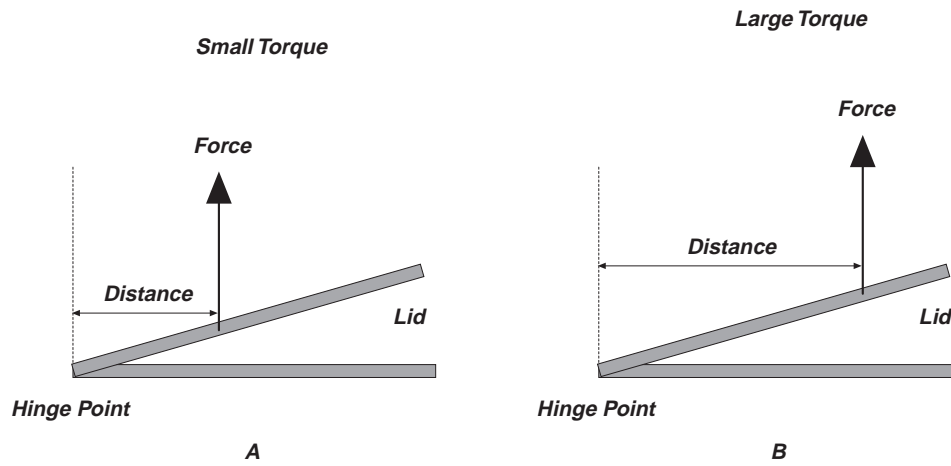

Figure 13.19: For the same force exerted on lid, the torque is larger in B than in A.

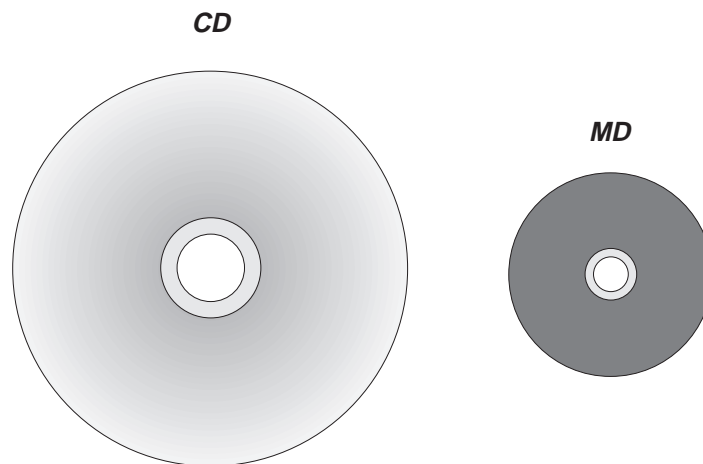

Figure 13.20: Moment of inertia of a CD is larger than that of a mini-Disc.