

n-th Roots

Cube roots

Suppose $g : \mathbb{R} \rightarrow \mathbb{R}$ is the cubing function $g(x) = x^3$.

We saw in the previous chapter that g is one-to-one and onto. Therefore, g has an inverse function.

The inverse of g is named the *cube root*, and it's written as $\sqrt[3]{}$. In other words, $g^{-1} : \mathbb{R} \rightarrow \mathbb{R}$ is the function $g^{-1}(x) = \sqrt[3]{x}$. The definition of inverse functions says that $\sqrt[3]{x^3} = x$ and $(\sqrt[3]{x})^3 = x$.

Inverse functions work backwards of each other:

$$4^3 = 64 \qquad \sqrt[3]{64} = 4$$

$$3^3 = 27 \qquad \sqrt[3]{27} = 3$$

$$2^3 = 8 \qquad \sqrt[3]{8} = 2$$

$$1^3 = 1 \qquad \sqrt[3]{1} = 1$$

$$0^3 = 0 \qquad \sqrt[3]{0} = 0$$

$$(-1)^3 = -1 \qquad \sqrt[3]{-1} = -1$$

$$(-2)^3 = -8 \qquad \sqrt[3]{-8} = -2$$

$$(-3)^3 = -27 \qquad \sqrt[3]{-27} = -3$$

$$(-4)^3 = -64 \qquad \sqrt[3]{-64} = -4$$

Notice that the domain of the cube root is \mathbb{R} . That means you can take the cube root of *any* real number.

To graph $\sqrt[3]{}$, first graph x^3 , and then flip the graph over the $x = y$ line as was described in the “Inverse Functions” chapter. The graph is drawn on the next page.

Graph of $\sqrt[3]{}$

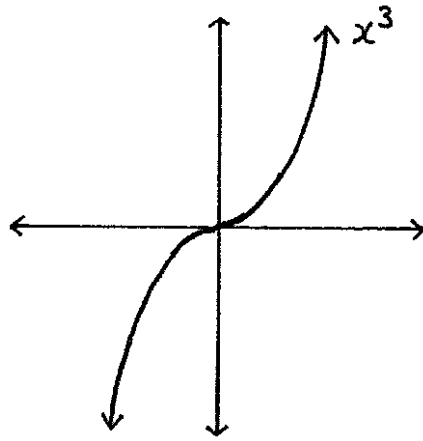

$$g: \mathbb{R} \rightarrow \mathbb{R}$$
$$g(x) = x^3$$

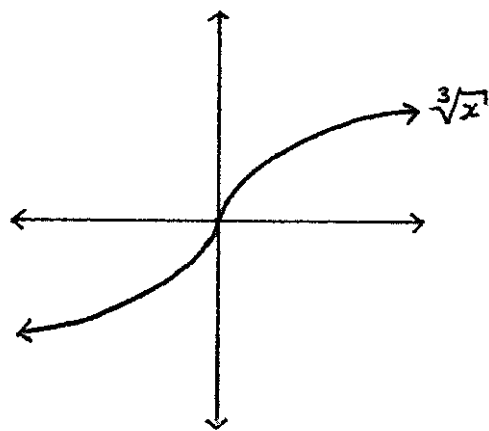
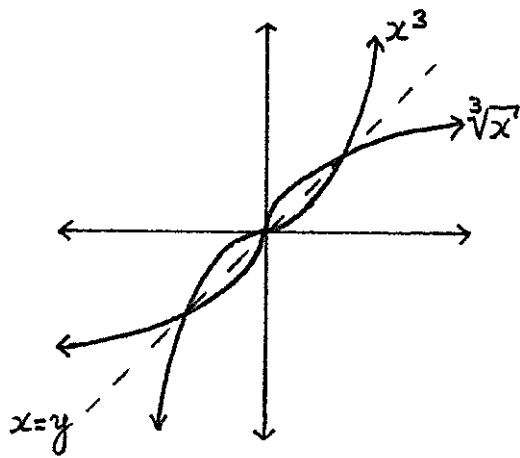

Square roots

Let $f : \mathbb{R} \rightarrow \mathbb{R}$ be the squaring function $f(x) = x^2$.

We saw in the previous chapter that f is neither one-to-one nor onto, so it has no inverse. But, there is a way to change the domain and the target of the squaring function in such a way that squaring becomes both one-to-one and onto.

If $h : [0, \infty) \rightarrow [0, \infty)$ is the squaring function $h(x) = x^2$, then we can check that the graph of h passes the horizontal line test and that the range of h is the same as its target, $[0, \infty)$. (The graph of h is drawn on the next page.) Therefore, h is one-to-one and onto and thus h has an inverse function, which is called the *square root* and is written as $h^{-1}(x) = \sqrt{x}$.

Notice that the domain of $\sqrt{}$ is $[0, \infty)$, and not \mathbb{R} . That means we can't square root a negative number. We cannot, under any circumstances, take the square root of a negative number.

$0^2 = 0$	$\sqrt{0} = 0$
$1^2 = 1$	$\sqrt{1} = 1$
$2^2 = 4$	$\sqrt{4} = 2$
$3^2 = 9$	$\sqrt{9} = 3$
$4^2 = 16$	$\sqrt{16} = 4$
$5^2 = 25$	$\sqrt{25} = 5$
$6^2 = 36$	$\sqrt{36} = 6$

The graph of $\sqrt{}$ is drawn on the next page.

Common shorthand

Often people will write \sqrt{x} to mean $\sqrt[3]{x}$. Be careful, \sqrt{x} can never be used as a shorthand for $\sqrt[3]{x}$.

Graph of $\sqrt{\quad}$

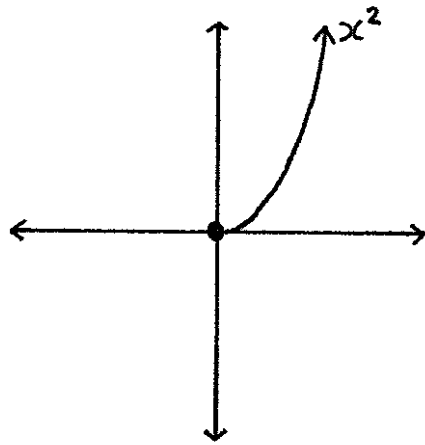

$$h: [0, \infty) \rightarrow [0, \infty)$$
$$h(x) = x^2$$

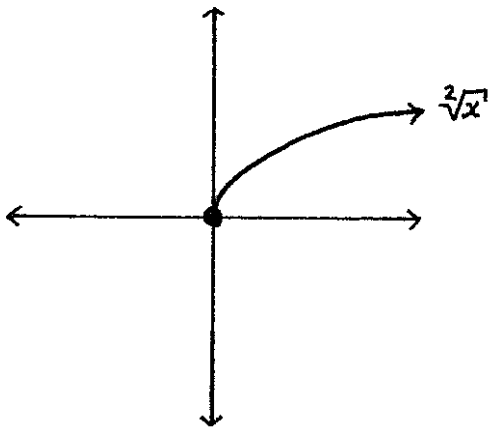
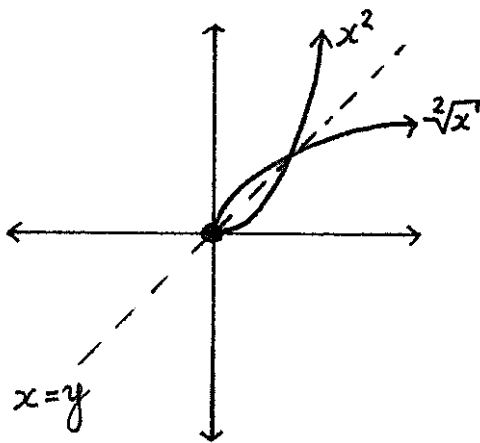

n-th roots

If $n \in \mathbb{N}$ and $n \geq 2$, then x^n describes a function.

The “odd exponent” functions $x^3, x^5, x^7, x^9, \dots$ are all different functions, but they behave similarly, and their graphs are similar. As a result of this similarity, if n is odd then x^n has an inverse function named $\sqrt[n]{} : \mathbb{R} \rightarrow \mathbb{R}$. In particular, the domain of $\sqrt[n]{}$ is \mathbb{R} whenever n is odd, so we can take an “odd root” of any real number, even a negative number.

On the other hand, the “even exponent” functions $x^4, x^6, x^8, x^{10}, \dots$ all behave like x^2 . If n is even, then $\sqrt[n]{} : [0, \infty) \rightarrow [0, \infty)$ is the inverse of x^n . That means that you can’t ever put a negative number into an even root function, and negative numbers never come out of even root functions.

Once more, you can take an even root of any positive number. You can take an even root of the number 0. But you can never take an even root of a negative number. Ever.

The most important thing to remember about n-th roots is that they are inverses of the functions x^n . That’s the content of the following two equations:

$$(\sqrt[n]{x})^n = x \quad \text{and} \quad \sqrt[n]{x^n} = x$$

Graph of $\sqrt[n]{}$ if n is odd ($n \geq 3$)

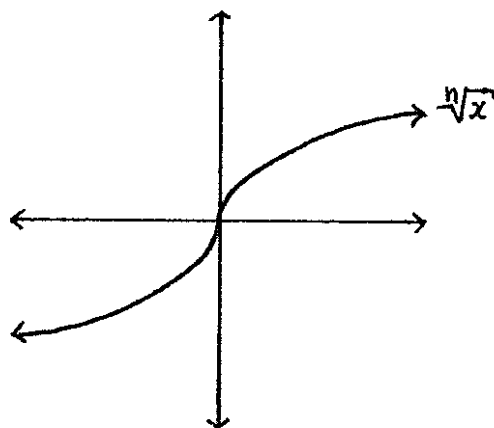

Graph of $\sqrt[n]{x}$ if n is even ($n \geq 2$)

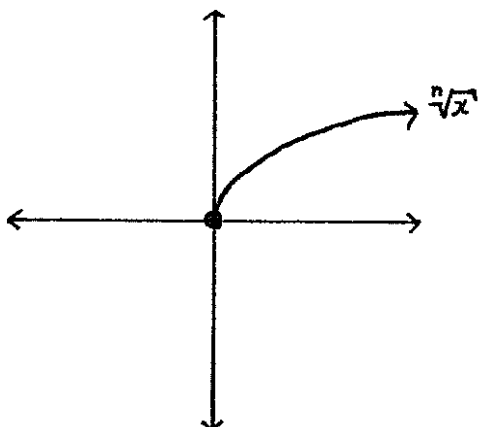

Using n-th roots

This section is a special case of the “Using inverse functions” section from the “Inverse Functions” chapter. Also compare to exercises #7-12 from the “Inverse Functions” chapter.

Problem 1. Solve for x where $2(x - 5)^3 = 16$.

Solution. First notice the order of the algebra on the left side of the equal sign: In the expression $2(x - 5)^3 = 16$, the first thing we do to x is subtract 5. Then we cube, and last we multiply by 2.

We can erase what happened last (multiplication by 2) by applying its inverse (division by 2) to the right side of the equation.

$$(x - 5)^3 = \frac{16}{2} = 8$$

Then we can erase the cube by applying its inverse (cube-root) to the right side.

$$x - 5 = \sqrt[3]{8} = 2$$

Then we can erase subtracting 5 by adding 5 to the right side.

$$x = 2 + 5 = 7$$

Problem 2. If $\sqrt[2]{2x} = 6$, what is x ?

Solution. Squaring is the inverse of the square root, so $2x = 6^2 = 36$, which means that $x = 18$.

* * * * *

Inequalities

Here are some rules for inequalities that you have to know.

If $a < b$, then:

$$a + d < b + d$$

$$a - d < b - d$$

$$ca < cb \quad \text{if } c > 0$$

$$cb < ca \quad \text{if } c < 0$$

$$a^n < b^n \quad \text{if } 0 \leq a < b$$

$$\sqrt[n]{a} < \sqrt[n]{b} \quad \text{if } 0 \leq a < b$$

$$\frac{1}{b} < \frac{1}{a} \quad \text{if } 0 < a < b$$

If $a \leq b$, then:

$$a + d \leq b + d$$

$$a - d \leq b - d$$

$$ca \leq cb \quad \text{if } c \geq 0$$

$$cb \leq ca \quad \text{if } c \leq 0$$

$$a^n \leq b^n \quad \text{if } 0 \leq a \leq b$$

$$\sqrt[n]{a} \leq \sqrt[n]{b} \quad \text{if } 0 \leq a \leq b$$

$$\frac{1}{b} \leq \frac{1}{a} \quad \text{if } 0 < a \leq b$$

* * * * *

Implied domains

Problem 1. What is the implied domain of $f(x) = \sqrt[3]{x^2 + 15}$?

Solution. For any $x \in \mathbb{R}$, x^2 is a real number. Add 15, and then $x^2 + 15$ is a real number. You can take a cube root of any real number, so $\sqrt[3]{x^2 + 15}$ is a real number.

To recap, any real number that you put into f results in a real number coming out, so the implied domain for f is \mathbb{R} .

Problem 2. What is the implied domain of $g(x) = \sqrt{x - 2}$?

Solution. We can't take the square root of a negative number. So $g(x)$ only makes sense if the number we are supposed to take the square root of, $x - 2$, is positive or 0. That means we need to have that $x - 2 \geq 0$. Therefore, after adding 2 to both sides of the previous inequality, $x \geq 2$.

The implied domain of g – which is all of those numbers that we may safely feed into g – is the set of all x such that $x \geq 2$. This set is $[2, \infty)$.

* * * * *

Some algebra rules for n-th roots

If $n \in \mathbb{N}$, $a > 0$, and $b > 0$, then

$$\begin{aligned}(ab)^n &= abababab \cdots abab \\ &= (aaaa \cdots aa)(bbbb \cdots bb) \\ &= a^n b^n\end{aligned}$$

Let's take two other positive numbers: $x > 0$ and $y > 0$. Since $\sqrt[n]{}$ is the inverse of the function x^n , we have $x = (\sqrt[n]{x})^n$ and $y = (\sqrt[n]{y})^n$. Thus, $xy = (\sqrt[n]{x})^n (\sqrt[n]{y})^n$.

If we let $a = (\sqrt[n]{x})$ and $b = (\sqrt[n]{y})$, then the above paragraph showed that $(\sqrt[n]{x})^n (\sqrt[n]{y})^n = (\sqrt[n]{x} \sqrt[n]{y})^n$. So we have that

$$xy = (\sqrt[n]{x})^n (\sqrt[n]{y})^n = (\sqrt[n]{x} \sqrt[n]{y})^n$$

Now we can erase the n -th power from the right side of the equation above by applying its inverse, $\sqrt[n]{}$, to the left side of the equation. That gives us the following equation on the next page.

$$\sqrt[n]{xy} = \sqrt[n]{x}\sqrt[n]{y}$$

A special case of the rule above is

$$\sqrt[n]{\frac{x}{y}} = \frac{\sqrt[n]{x}}{\sqrt[n]{y}}$$

You might be tempted at some point to write that $\sqrt[n]{x+y}$ is the same thing as $\sqrt[n]{x} + \sqrt[n]{y}$, but it is not. For example, $\sqrt[2]{9+16} = \sqrt[2]{25} = 5$, but $\sqrt[2]{9} + \sqrt[2]{16} = 3 + 4 = 7$, and 5 does not equal 7.

$$\sqrt[n]{x+y} \neq \sqrt[n]{x} + \sqrt[n]{y}$$

Simplifying square roots of natural numbers

When writing the square root of a natural number, you'll usually be expected to write a final result that does not include taking the square root of a number that is a square. For example, you should write $\sqrt{4}$ as 2, because $4 = 2^2$ and $\sqrt{2^2} = 2$.

You can use the rule $\sqrt{xy} = \sqrt{x}\sqrt{y}$ to help you remove squares from the inside of a square root. For example, $20 = (2)(2)(5) = 2^2 5$. Thus,

$$\sqrt{20} = \sqrt{2^2 5} = \sqrt{2^2}\sqrt{5} = 2\sqrt{5}$$

For one more example, if asked for $\sqrt{360}$, first factor 360 into a product of prime numbers to see that $360 = 2^3 3^2 5 = 2^2 3^2 (2)(5)$. Then we have

$$\sqrt{360} = \sqrt{2^2}\sqrt{3^2}\sqrt{(2)(5)} = (2)(3)\sqrt{(2)(5)} = 6\sqrt{10}$$

You can be sure that you are done simplifying at this point because 10 written as a product of primes is $(2)(5)$, and this product does not include more than one of the same prime number.

Exercises

- 1.) What is x if $(x + 7)^3 = 8$?
- 2.) Solve for x where $\sqrt{x + 2} = 4$.
- 3.) If $4(2x + 7)^5 = 12$, then what is x ?
- 4.) Find x when $3\sqrt[4]{4 - x} = 9$.
- 5.) What is the inverse function of $f(x) = x^3 + 5$?
- 6.) What is the inverse function of $g(x) = 4\sqrt[3]{x + 7}$?

In #7-13, solve the inequality for x .

- 7.) $2x - 13 < 4$
- 8.) $-3x < 16 + x$
- 9.) $\frac{4}{x} > \frac{1}{9}$
- 10.) $\sqrt[5]{2x - 6} > 2$
- 11.) $12 \leq -x^3 + 4$
- 12.) $\sqrt[2]{3x} \geq 1$
- 13.) $\frac{12}{3-x} \geq 24$

In #14-17, find the implied domains of the given functions.

- 14.) $f(x) = \sqrt[15]{3x^2 - 14x + 9}$
- 15.) $g(x) = \sqrt[2]{17 - 2x}$
- 16.) $h(x) = 5\sqrt[2]{9x - 4}$
- 17.) $f(x) = 10 - \frac{\sqrt[8]{-2x+4}}{x^2+1}$

Simplify the expression in #18-23.

- 18.) $\sqrt{27}$
- 19.) $\sqrt{24}$
- 20.) $\sqrt{100}$
- 21.) $\sqrt{52}$
- 22.) $\sqrt{150}$
- 23.) $\sqrt{48}$

For #24-30, match the numbered functions with their lettered graphs.

24.) x^2

25.) $\sqrt[2]{x}$

26.) $\sqrt[2]{x} + 1$

27.) $\sqrt[2]{x} - 1$

28.) $2\sqrt[2]{x}$

29.) $\frac{\sqrt[2]{x}}{2}$

30.) $-\sqrt[2]{x}$

A.)

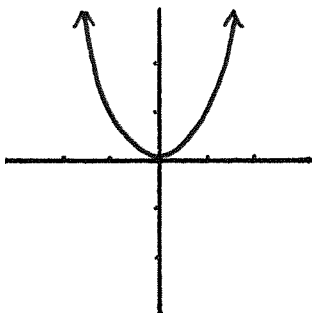

B.)

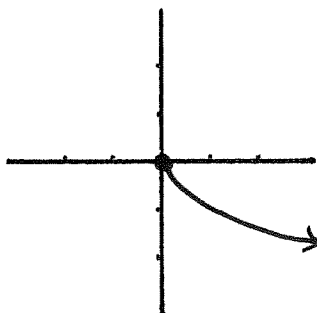

C.)

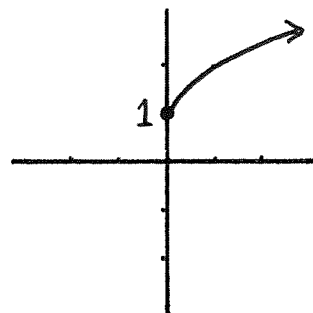

D.)

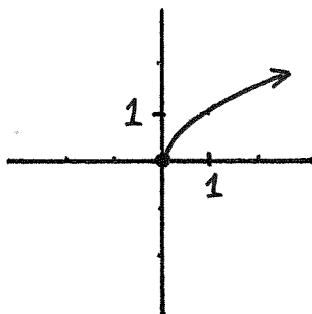

E.)

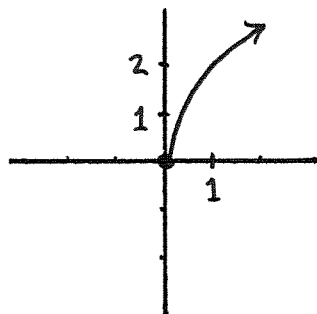

F.)

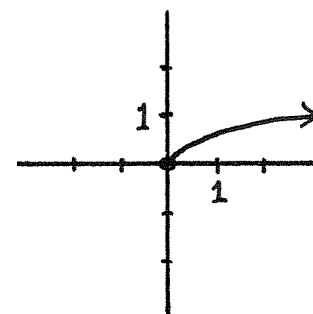

G.)

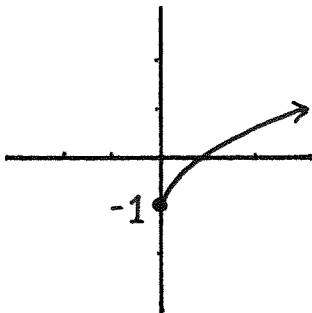

For #31-37, match the numbered functions with their lettered graphs.

31.) x^2

32.) $\sqrt[2]{x}$

33.) $\sqrt{x+1}$

34.) $\sqrt{x-1}$

35.) $\sqrt[2]{2x}$

36.) $\sqrt{\frac{x}{2}}$

37.) $\sqrt[2]{-x}$

A.)

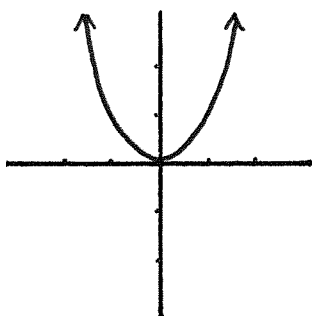

B.)

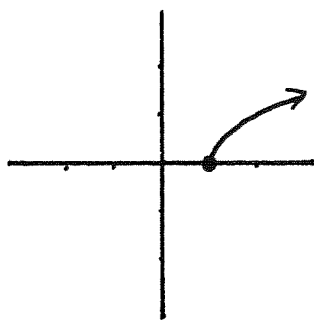

C.)

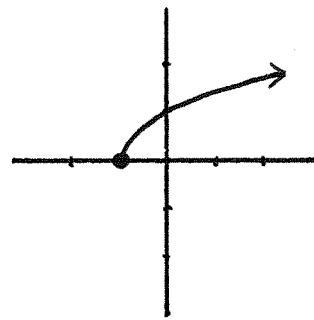

D.)

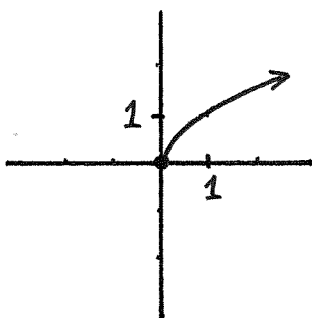

E.)

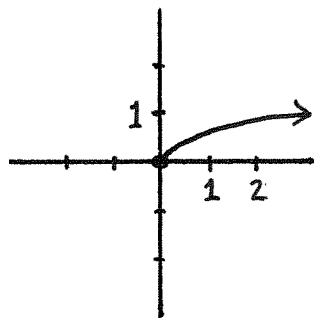

F.)

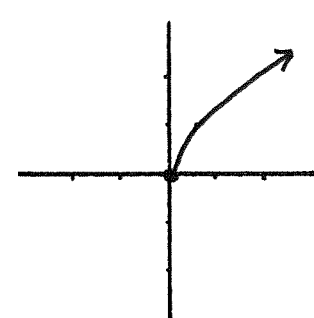

G.)

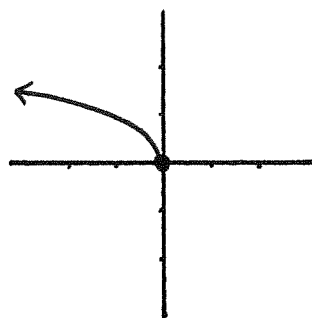

For #38-46, match the numbered functions with their lettered graphs.

38.) $\sqrt[2]{x}$

39.) $\sqrt[2]{x+1} + 1$

40.) $\sqrt[2]{x+1} - 1$

41.) $\sqrt[2]{x-1} + 1$

42.) $\sqrt[2]{x-1} - 1$

43.) $-\sqrt[2]{-x}$

44.) $\sqrt[2]{-x} + 1$

45.) $-\sqrt[2]{x+1}$

46.) $-\sqrt[2]{x} - 1$

A.)

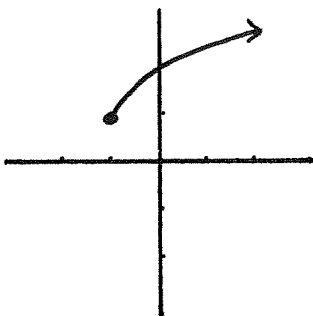

B.)

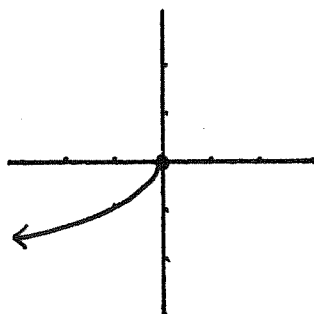

C.)

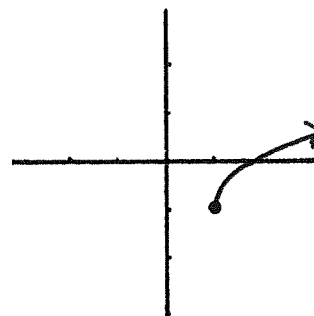

D.)

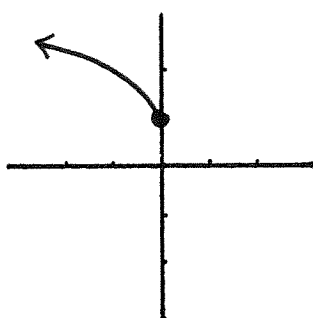

E.)

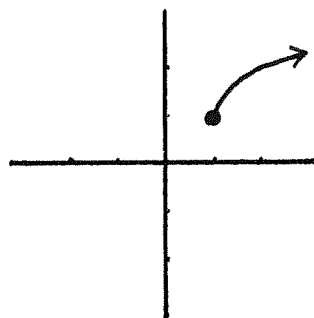

F.)

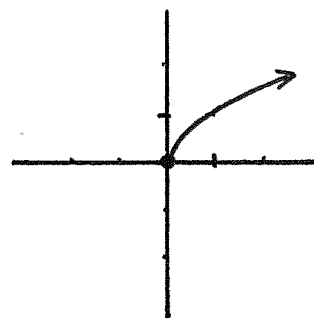

G.)

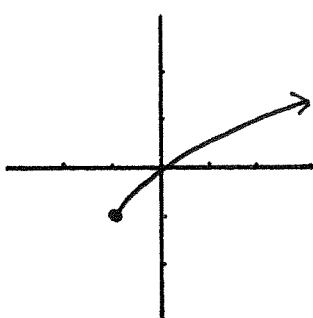

H.)

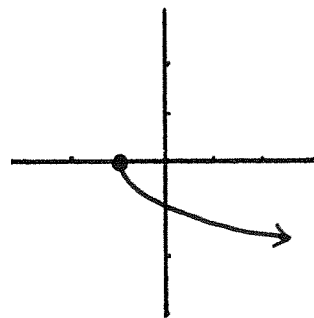

I.)

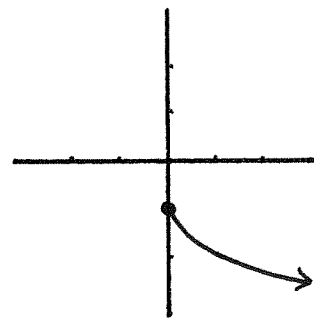

For #47-53, match the numbered functions with their lettered graphs.

47.) x^3

48.) $\sqrt[3]{x}$

49.) $\sqrt[3]{x} + 1$

50.) $\sqrt[3]{x} - 1$

51.) $2\sqrt[3]{x}$

52.) $\frac{\sqrt[3]{x}}{2}$

53.) $-\sqrt[3]{x}$

A.)

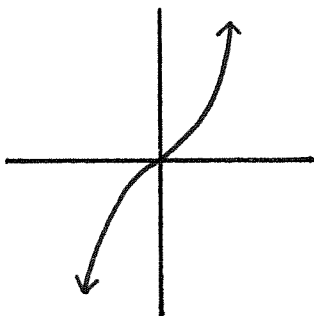

B.)

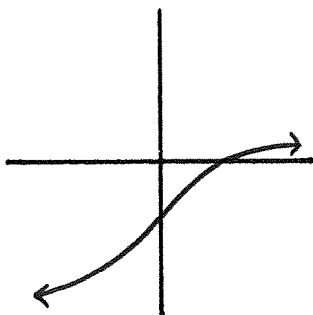

C.)

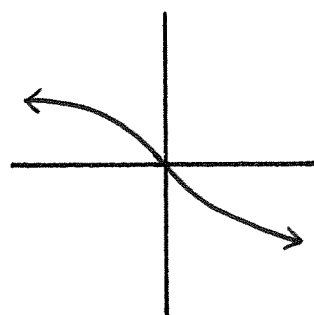

D.)

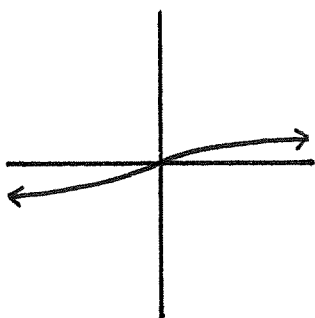

E.)

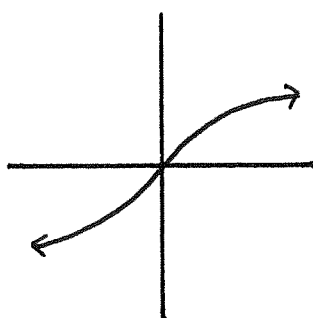

F.)

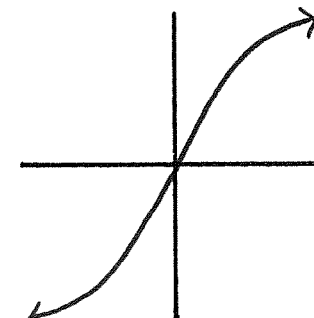

G.)

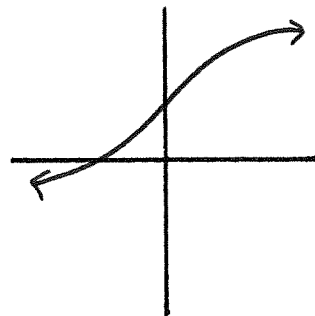

For #54-60, match the numbered functions with their lettered graphs.

54.) x^3

55.) $\sqrt[3]{x}$

56.) $\sqrt[3]{x+1}$

57.) $\sqrt[3]{x-1}$

58.) $\sqrt[3]{2x}$

59.) $\sqrt[3]{\frac{x}{2}}$

60.) $\sqrt[3]{-x}$

A.)

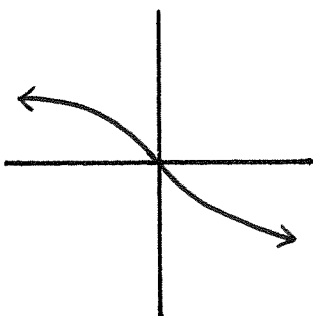

B.)

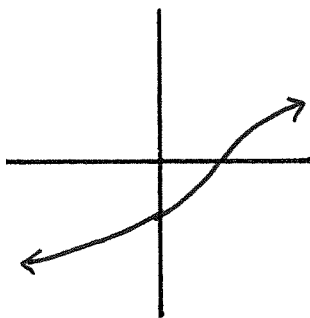

C.)

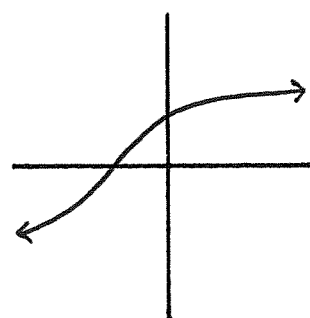

D.)

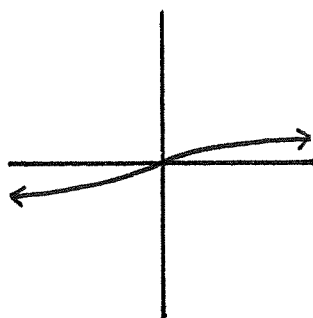

E.)

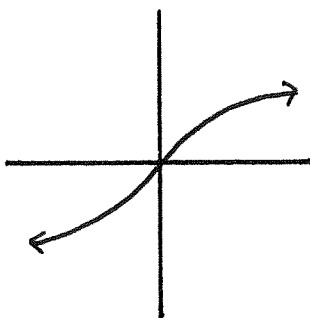

F.)

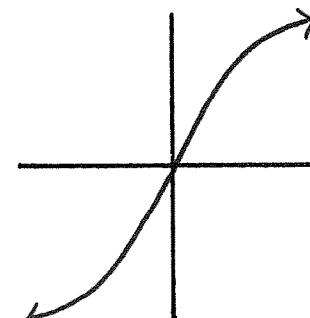

G.)

